



The Altendorf WA 6:  
compact, powerful, outstanding.





WA 6 in CE version,  
shown with 2600 mm double roller carriage



WA 6 in non-CE version,  
shown with 2600 mm double roller carriage

## Compact, but an Altendorf.

What to do when one has little space, plus a limited budget, but quality must still be maintained? When these requirements must be met by a sliding table saw, Altendorf's answer is: an Altendorf WA 6. The WA 6 is the smallest Altendorf there is. But in spite of its smaller dimensions, its considerable abilities are impressive: with its powerful range of equipment, it stands out even in the smallest space. Outstanding for its cut quality and its flexibility in everyday use. And just as outstanding is the price. So what else is there to be concerned about?



The proven Altendorf double roller carriage with steel bar guidance.

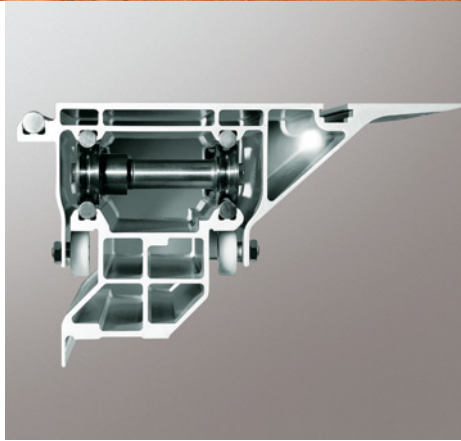

The multi-chamber system for maximum rigidity of the double roller carriage.

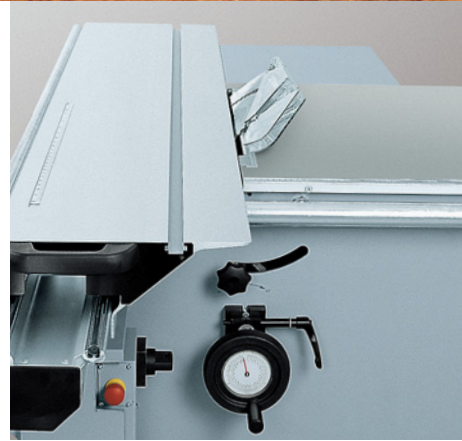

Manual tilt adjustment.



Manual rise/fall adjustment.

**Altendorf – the world market leader in professional sliding table saws.**

The Altendorf WA 6 is a quality sliding table saw for professional demands. Since the establishment of the company and the invention of the sliding table saw by Wilhelm Altendorf in 1906, Altendorf has been a synonym throughout the world for this type of machine. Altendorf has for decades been the unchallenged world market leader, and has now sold well over 120 000 sliding table saws in more than 120 countries around the globe. Altendorf manufactures at two production sites, in Minden, Germany, and in Qinhuangdao, China, using the latest technology and the highest standards.



The WA 6 cleanly cuts wood, plastics and non-ferrous metals.



Safety hood with extraction hose above the main saw blade. CE version: extraction hose included in the basic specification; non CE-version: optional.

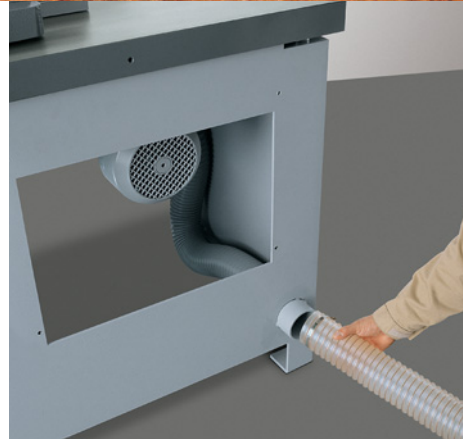

Extraction supports on the machine pillars (extraction socket: Ø 90 mm).



Crosscut-mitre fence: for accurate angle and mitre cutting in a single function. Cutting lengths: 95–2600 mm. Mitre angle infinitely adjustable from 0–49°.



The rip fence, smooth and precise.

### Big value from a small machine:

#### Specification:

Double roller carriage: 1 600, 2 000 or 2 600 mm

Cutting length: 1 450, 1 850 or 2 500 mm

Saw blade diameter:

CE version: max. 315 mm

(cutting height max. 87 mm);

non-CE version: max. 350 mm

(cutting height max. 105 mm)

Cutting width to rip fence: 1 000 mm

Crosscutting on the crosscut-mitre fence up to

2 600 mm

#### Motor:

Drive rating: 4 kW (5.5 HP)

Speed: 4 200 rpm

Scoring unit: 0.37 kW (0.5 HP)

#### Saw blade adjustment:

Height adjustment: manual with hand wheel

Tilt adjustment: manual with hand wheel, tilt angle indicated on a scale. From 0–45°.

#### Hood:

CE version: safety hood for max. saw blade diameter of 315 mm, mounted on the riving knife, with extraction hose above the main saw blade

Non-CE version: safety hood for max. saw blade diameter of 350 mm, mounted on the riving knife. Optional: with extraction hose above the main saw blade

#### To the left of the saw blade:

Precise, robustly mounted crosscut-mitre fence for simple setting and accurately reproducible 90°

Perfectly square connection of cross slide to sliding table

Flip stops with bilateral mountings clamp tightly to securely hold the set dimension

Easily removable cross slide

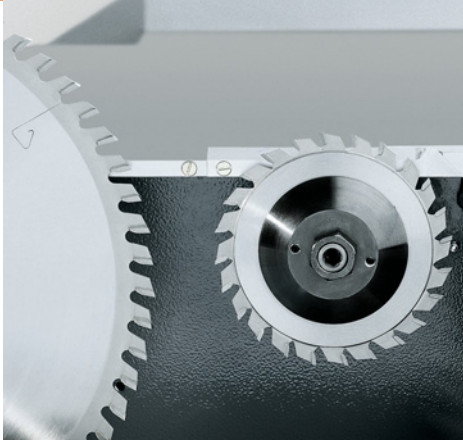

The scorer. Separate 0.37 kW scoring motor with on/off switch.



Short sliding table: if requested the machine can also be supplied with 1 600 mm table.

## Perfect working from the word go.

Working with the WA 6 is a joy from the word go: the well thought-out and professional concept of the machine is immediately apparent. The finish is of the best engineering quality. Using the comprehensive range of equipment any cuts can be made with no difficulty, even down to special angle and mitre cuts. The machine is delivered to you fully preadjusted. So after just a few operations you can get going immediately. And the competitive price makes its contribution to the pleasure of owning an Altendorf WA 6.

### Technical specifications

#### Sliding table cutting lengths

Sliding table length	With or without scoring saw blade
1 600 mm	1 450 mm
2 000 mm	1 850 mm
2 600 mm	2 500 mm

*These cutting lengths refer to mechanical travel, i.e. from end stop to end stop on the sliding table.*

#### Cutting heights

Saw blade diameter, in mm	250	300	315	350
Cutting height at 90°, in mm	0–55	0–80	0–87	0–105
Cutting height at 45°, in mm	0–38	0–56	0–60	0–73

#### Space requirement

- A** Sliding table length + 220 mm up to 2 000 mm double roller carriage  
Sliding table length + 290 mm over 2 000 mm double roller carriage
- B** Sliding table length + 220 mm
- C** 873 mm up to 2 000 mm double roller carriage  
1 273 mm over 2 000 mm double roller carriage

#### Machine weight

450 kg

#### Table height

910 mm

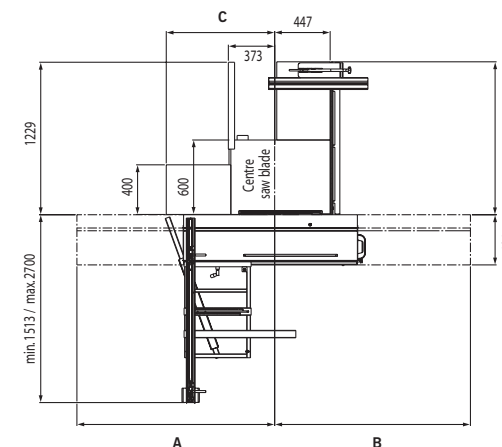

# Solid wood applications

## Trimming and ripping



The clamping shoe secures the board on the double roller carriage.



Align and trim the material along the cutting line.



Guide the workpiece along the rip fence and over the rotating saw blade, using the push stick if necessary.

## Sizing



Make a square cut.



Position the rip fence in front of the saw blade, set to the required length and cut.



Cut the remaining piece to size on the crosscut fence.

## Chamfering and concealed cuts



Fix the workpiece under the clamping shoe and cut the chamfer.

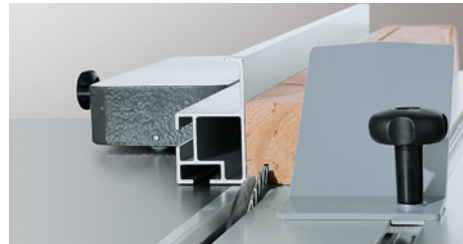

Set the height of the blade and the width on the rip fence.

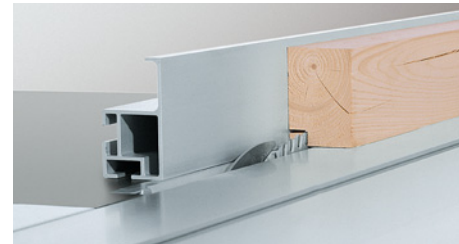

Set the height of the riving knife to 2 mm below the top of the saw blade teeth and position the rip fence behind the saw blade.

# Panel applications

## Squaring



Align the panel and make a trim cut.



Turn the panel anti-clockwise and place the trimmed edge against the fence.



Cut to square.

## Dividing up and sizing

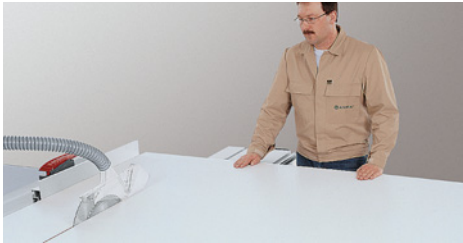

Cut panel strips on the rip fence.



Cut panel strips to final length on the rip fence.



Cut the remaining piece to size on the crosscut fence.

## Angle and mitre cuts



Tilt the saw blade to the desired angle, lay the workpiece against the crosscut fence.

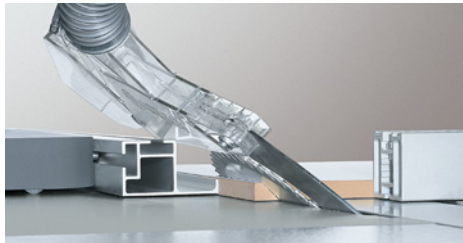

Bevel ripping on the rip fence with workpiece on the sliding table.



Mitre cut using crosscut-mitre fence.

[www.altendorf.com](http://www.altendorf.com)

Wilhelm Altendorf GmbH & Co. KG Maschinenbau · Wettinerallee 43/45 · D-32429 Minden · Germany  
Telephone +49 (0)571 9550-0 · Fax +49 (0)571 9550-111 · [sales@altendorf.de](mailto:sales@altendorf.de)

