

Improved for you according
to our standards.

T70

MARTIN



T70

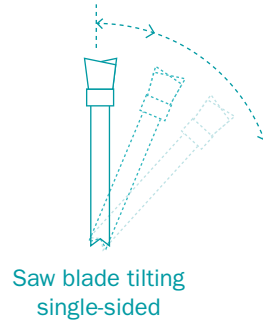

A classic that has set standards for us.
And now for you too.

Like every MARTIN, the T70 is built for robust performance inside and out. The solid mechanics perfectly complement the unique ease of use of the sophisticated 10.4" touchscreen controller.

Because we don't just set standards in technology, but in operation as well: You are supported in all operational and work processes according to the situation – customised on request.

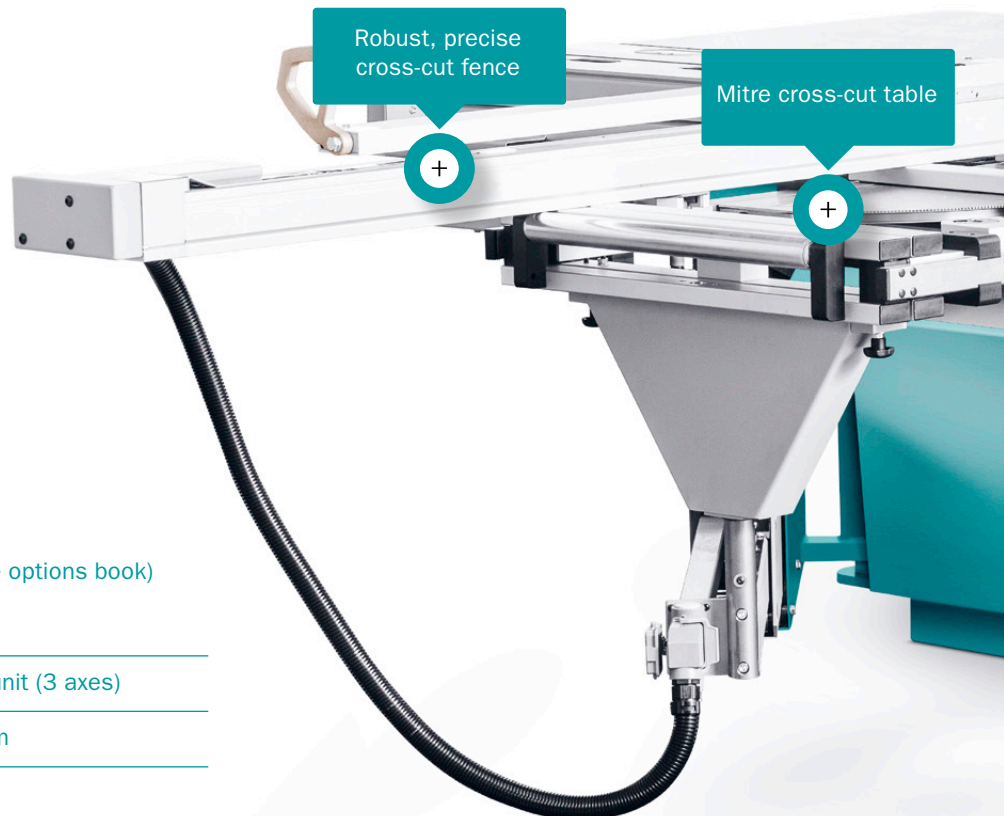

T70 with accessories (further details in the options book)

T7009/2 | Cutting width 1,100 mm

T7023 | Electrically adjustable scoring-saw unit (3 axes)

T7050 | RadioCompens angle cutting system

T7073 | Laser cutting line indicator

T7074 | Rip fence pneumatically lowerable

T7076 | Infinitely variable speed for the main saw blade

Modern touchscreen control

Time savings when working.

The T70 supports you with its 10.4" touchscreen controller to the maximum performance level. The modern machine operation ensures the machine is easy to use. The operating logic is based on the needs of the operator and the control system is intuitive to use.



Modern
touchscreen

+

Belt change from
above

+

Sliding table
with replaceable
table edge

+

Lowerable
rip fence

+

Strong composite
frame

+

MARTIN

T70

Quick, precise, flexible. The rip fence.

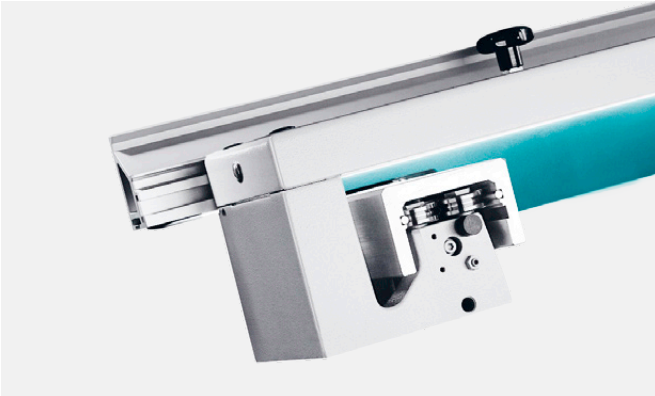

Rip fence guide | Standard

The T75 is fitted with the optional controlled rip fence as standard, which effectively supports the cutting width with quick and accurate positioning. The intuitive operation via the touchscreen control system reduces dimensional errors and contributes significantly to perfect cutting results. The fence is intricately and accurately guided by four solid grooved ball bearings. This design ensures maximum durability and thus



Rip fence pneumatically lowerable | T7074

angular accuracy with constantly smooth running. The stable rip fence moves freely over the table without support and remains unaffected by dirt and chips on the table. In order to be able to move the stop quickly and easily without a controller, you only need to press a button on the stop and easily move it to the desired position.

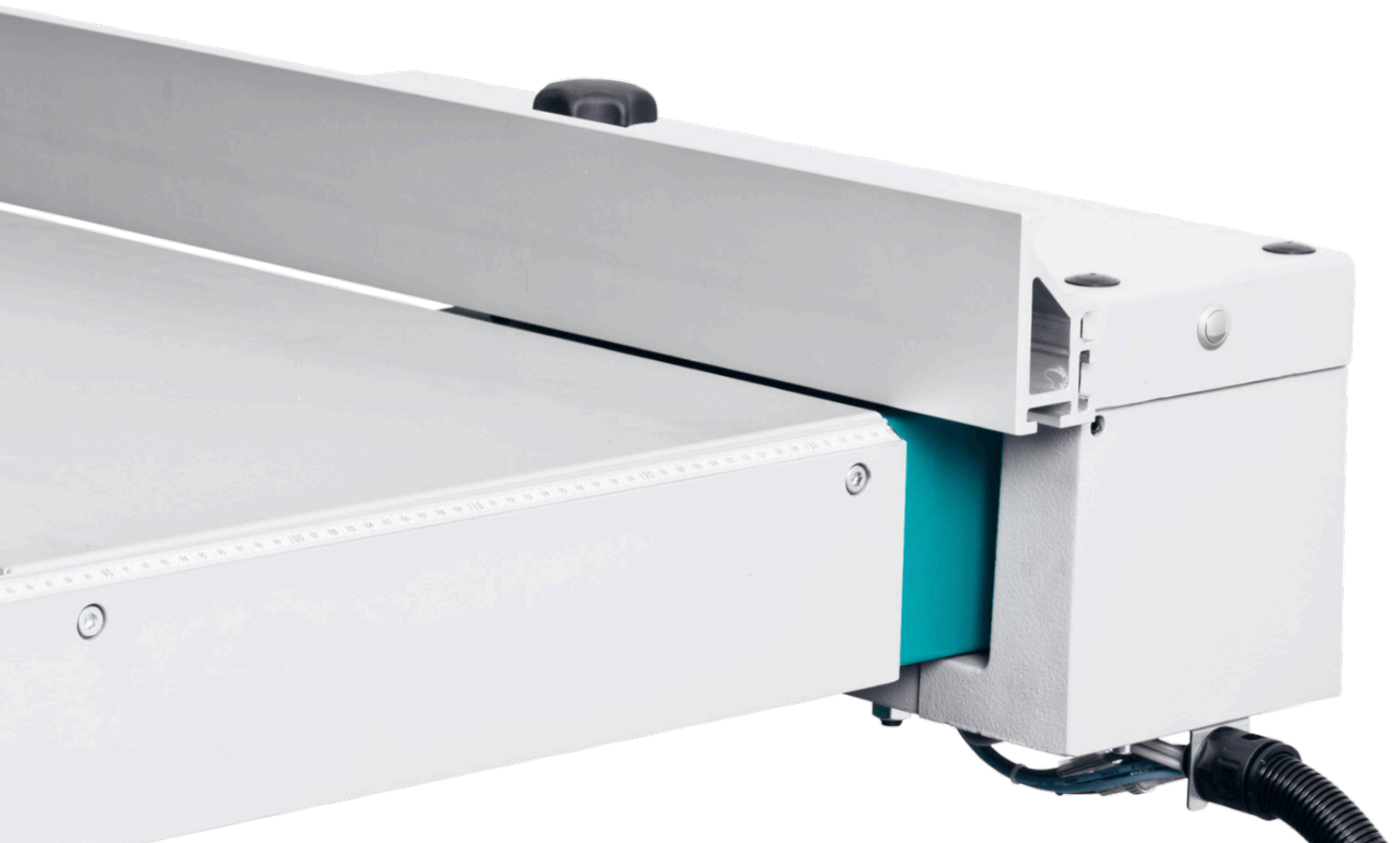

Robust, solid and durable design.

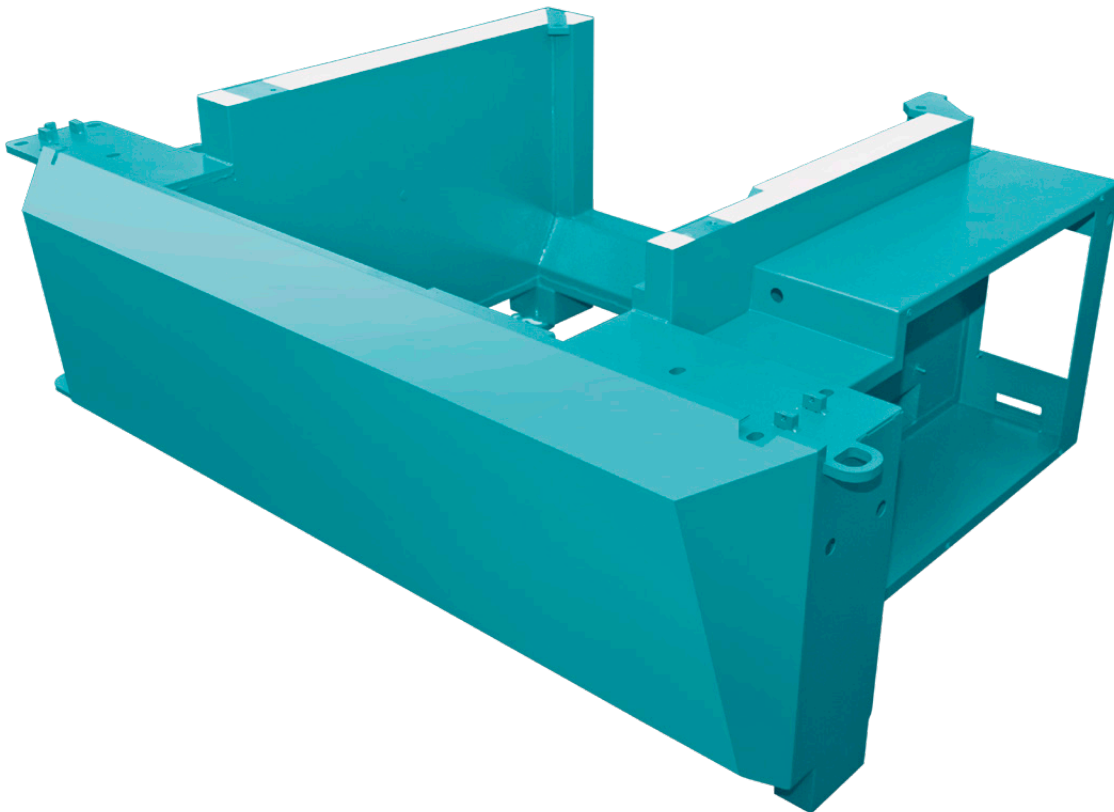

The unique construction of the MARTIN rip fence delivers incomparable precision.

The basis for your success.

The machine frame of the T70 is a stable, thick walled composite structure, that is only found in MARTIN products. Already back in the 1920s Otto Martin invented and registered this design. Today, after 20 years of continuous improvement, this simple yet good principle of frame construction is still used. The smart combination of steel and concrete creates a high quality frame unequalled in terms of stability, damping capacity and torsional stiffness. The vibrations that occur in any saw are absorbed much more effectively than in cast iron frames or welded structures. This frame is the perfect base for your perfect work!

Composite frame | Standard

From now on cut without tearing.

A scoring prevents workpiece tear-out on the edges of veneered and laminated panels. Two versions are available for the T70. Both units are switched on and off and positioned electrically. Raising and lowering are performed pneumatically at unmatched speeds. The 2-axis system adjusts its left/right position fully automatically in accordance with the right cutting edge of the used main saw blade. The scoring height is prescribed electronically. Both positions are always saved appropriately for the saw blade. The scoring width, i.e. the position relative to the left edge of the main saw blade, is adjusted when the machine is at a standstill in all traditional systems.



2-axis scoring-saw unit | T7020



Maximum comfort, highest accuracy.

Thanks to its complete, patented integration into the control system, the MARTIN 3-axis system offers extreme comfort and top precision. The system is referenced once. Then it adjusts itself in line with the new saw blade with all three axes and fully automatically after a change of the main saw blade. All axes (scoring height, scoring position, and scoring width) are positioned without further action and are monitored electronically. This offers the decisive advantage that all scorer settings that are relevant for the cutting quality are directly related to the relevant main saw blade and are always made automatically, quickly, and precisely. There is no need for time-consuming test cuts.

3-axis scoring-saw unit | T7023



Quick and easy from above.

In all T70 machines the speed is conveniently changed by an opening in the machine table. An even more precise speed change can be achieved using the optional continuous rotational speed control. You can effortlessly adapt the speed at the push of a button. Main and scoring-saw blades are quick and easy to change thanks to the ProLock system.



Saw blade can be tilted to the right

Powerful and precise up to 204 mm height.

The large cutting height of 204 mm and the tilting range of 0 to 46° provide clearances for demanding operations. The motor rating of up to 11 kW ensures sufficient power for even the most challenging work.

T70

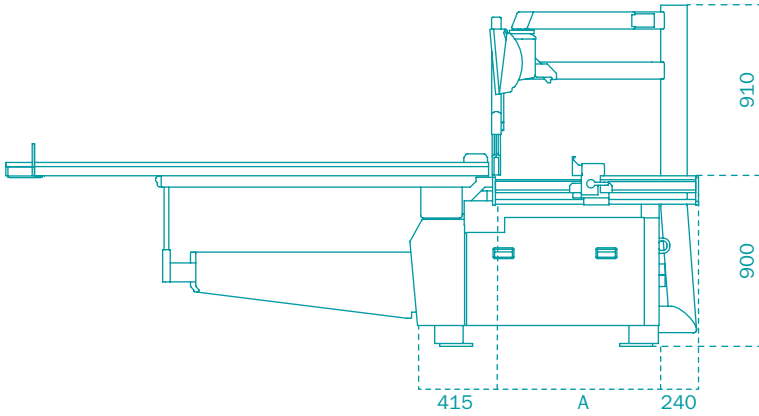

T70 | Side view

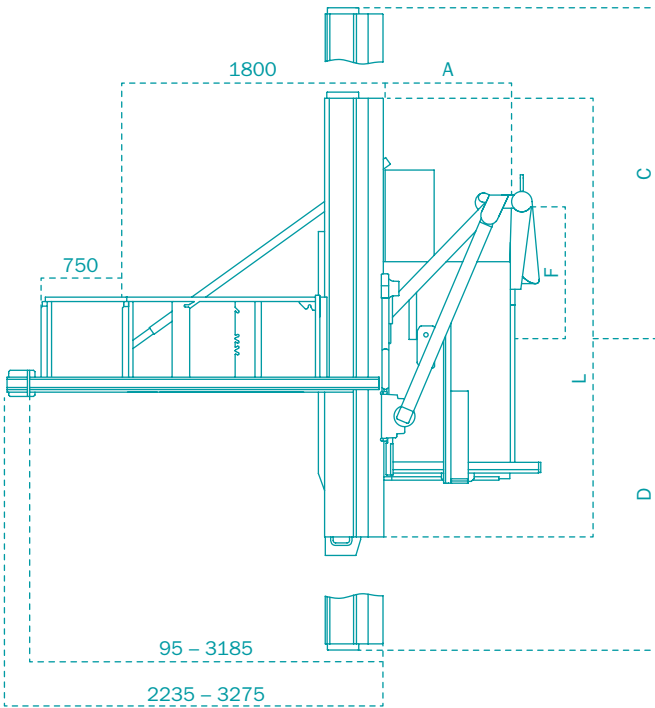

T70 | Plan view

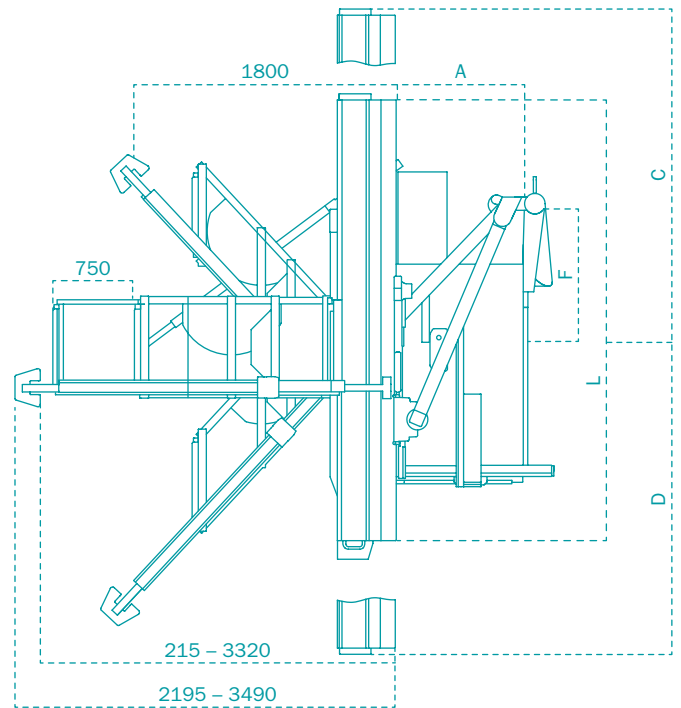

T70 | Plan view

A Cutting width	F Clearance	L Sliding-table length	Sliding cut	C D Movement range
850	920	1,900	1,900 x 1,900	2,500 2,400
1,100	920	3,000	3,000 x 3,000	3,600 3,500
1,350	920	3,300	3,300 x 3,300	3,900 3,800
1,600	920	3,700	3,310 x 3,700	4,300 4,200
		4,300	3,310 x 3,700	4,900 4,800

Technical data	T65	T70	T75 PreX
Motor power optional	5.5 kW 7.5 kW 11.0 kW	5.5 kW 7.5 kW 11.0 kW	7.5 kW 9.5 kW 11.0 kW
Cutting height	550 mm	550 mm	550 mm
Saw blade tilting range	46°	46°	± 46°
Saw blade diameter	550 mm	550 mm	550 mm
Speed optional	2,800 4,000 5,000 rpm –	2,800 4,000 5,000 rpm –	3,800 rpm 2,000 – 6,000 rpm continuous
Main saw blade change	ProLock	ProLock	ProLock
Blade thickness	max. 6 mm special tools up to 20.0 mm (0°)	max. 6 mm special tools up to 20.0 mm (0°)	max. 6 mm
Cutting width optional	850 mm 1,100 1,350 1,600 mm	850 mm 1,100 1,350 1,600 mm	850 mm 1,100 1,350 1,600 mm
Sliding table length optional	3.0 m 1.9 3.3 3.7 4.3 5.1 m	3.0 m 1.9 3.3 3.7 4.3 5.1 m	3.0 m 1.9 3.3 3.7 4.3 5.1 m
Control	5.7" touchscreen	10.4" touchscreen	5.7" touchscreen optional 10.4" touchscreen
Display resolution	0.1 mm 0.1°	0.1 mm 0.01°	0.1 mm 0.01°
Control panel	at eye level, inclined, 2x rotation	at eye level, inclined, 2x rotation	at eye level, inclined, 2x rotation
Cutting angle/height	controlled	controlled	controlled
Cutting width	manually, by scale with fine adjustment optionally by hand wheel including digital dimension indicator, controlled	controlled	manually, by scale including digital dimension indicator optionally controlled
Extraction connection	120 mm on frame 100 mm on guard	120 mm on frame 100 mm on guard	120 mm on frame 100 mm on guard
Weight	approx. 1,600 – 2,100 kg	approx. 1,600 – 2,100 kg	approx. 1,600 – 2,100 kg

The machines generate very little dust as per BGI 739-1 Annex 1.

All dimensions in millimetres. Manufactured in Germany.

Dimensions and specifications subject to technical innovation and may be changed without notice.

Illustrations may differ from the original. The binding technical features and equipment are given in the applicable price list.

Visit us at:

Website



Facebook



YouTube



Brochure



Contact us at:
+49 (0) 8332 911 - 0
sales@martin.info

MARTIN