

SE



Record 125

CNC machining centres

D

S

N



 **scm**

Record 125

CNC machining centre

The complete machining centre

A compact machining centre with unbeatable performance levels for this category.

The low investment required makes it ideal for medium- and small-sized woodworking companies alike. Its function range and power make it the ideal tool for large companies too, as a back-up machine for special operations.

- The powerful and reliable machining head is mounted on a high-rigid, solid structure, a guaranty for high-quality finish.
- The new ergonomic design with large transparent enclosure enables the operator to see in total safety the component being machined.
- This machining centre is a leader for operator safety and environmental protection.



A new ergonomic design allows the check of the entire working area under totally safe operating conditions.



Improved waste pickup and dust reduction by extraction system inside the guards.



Axis stroke on prism guides with recirculating ball screws to guarantee maximum stability and smooth sliding. Two features guaranteeing a high quality finish under any machining conditions.

Pre-loaded recirculating ball screws for smooth and precise movements.

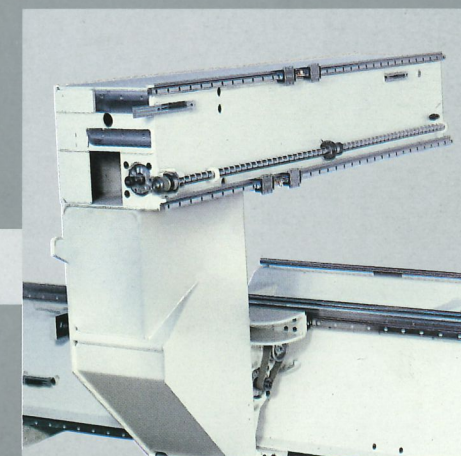

e scm



Record
125

Record
125 N

Machining head

Routing unit:

Mounted directly on the machine bed to guarantee high strength and durability. The electro-spindle is built into the single-piece base unit. Leading edge technology and performance levels guaranteeing a top quality finish.

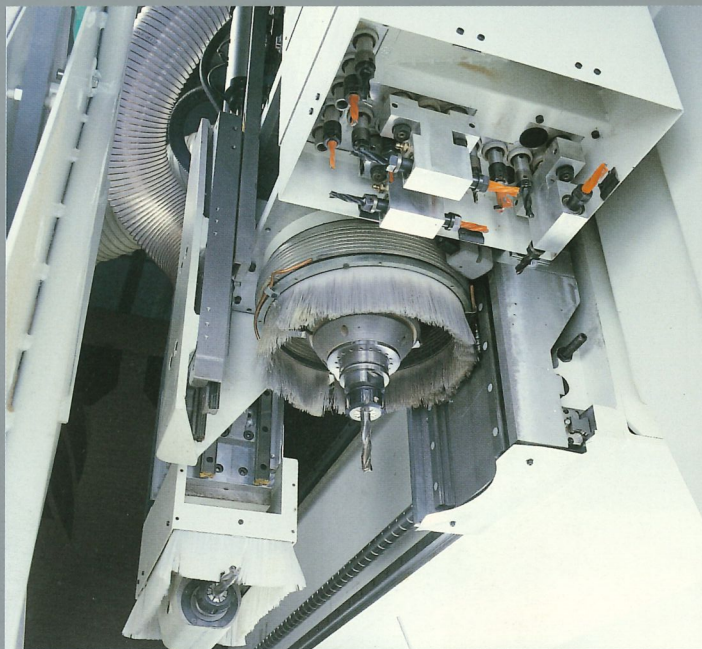

HSK 63 F tool taper which guarantees maximum hold-down rigidity and precision to ensure a high-quality finish for all applications. Exclusive SCM taper cleaning system for precise coupling under any machining conditions.

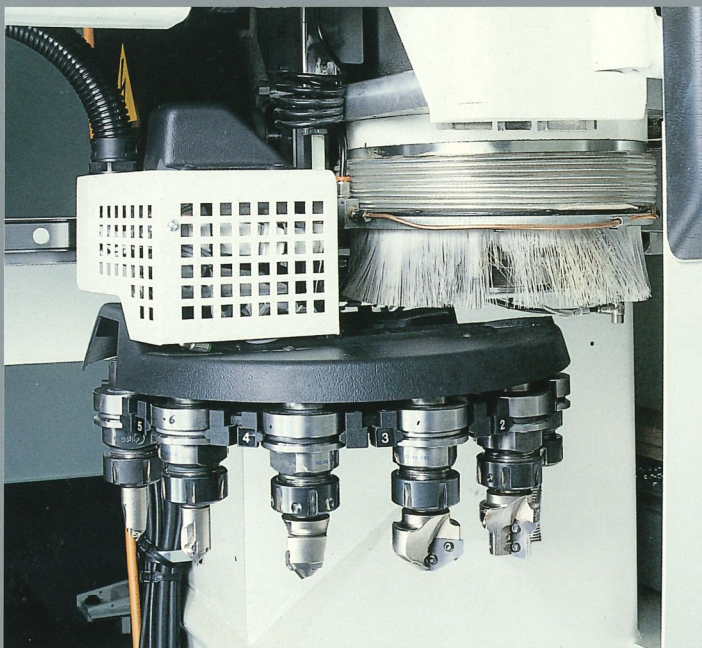
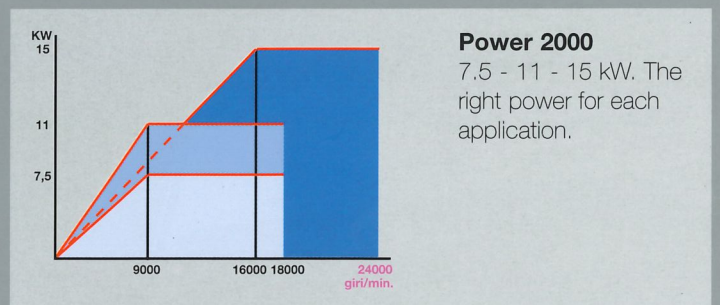
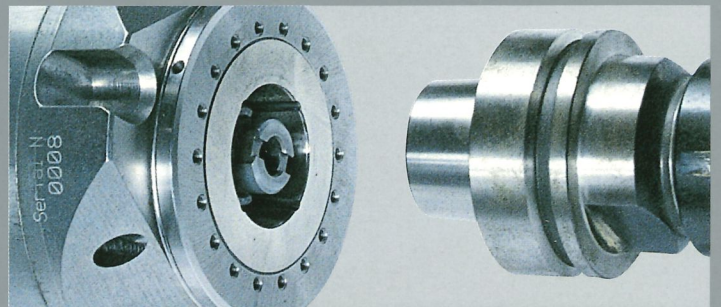

Rapid 12

Automatic 12-position tool changer for machining different types of profile all during the same cycle.



Vector rotary axis: for using special angle drive units which can be tilted 0-360° CNC using the CNC

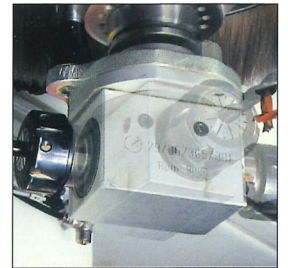

Drilling unit with 9 and 18 independent drilling spindles specifically designed for solid wood drilling.

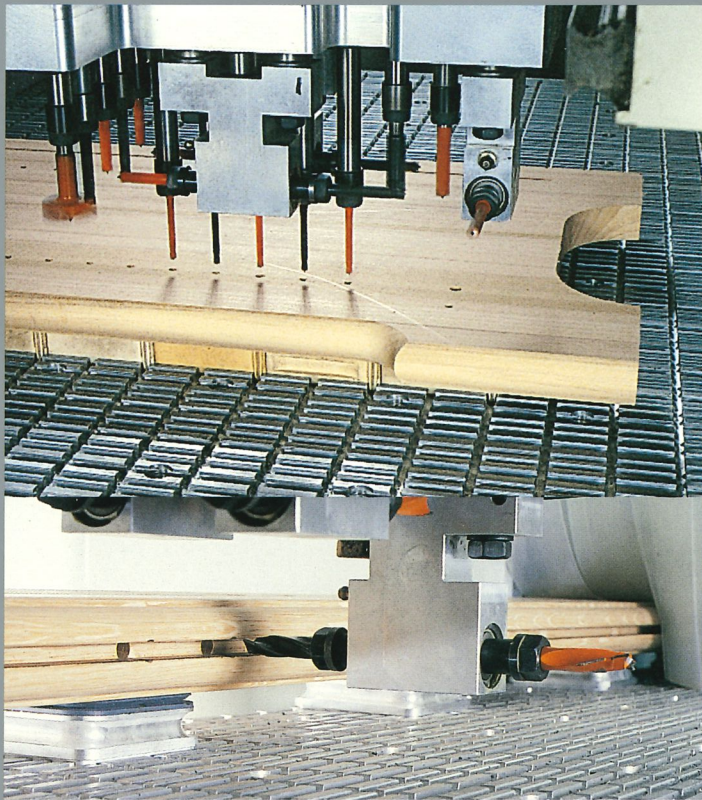

Sawing blade unit. Can rotate from 0 to 90° or from 0 to 360°, CNC controlled. Fast and powerful for sawing any kind of material.

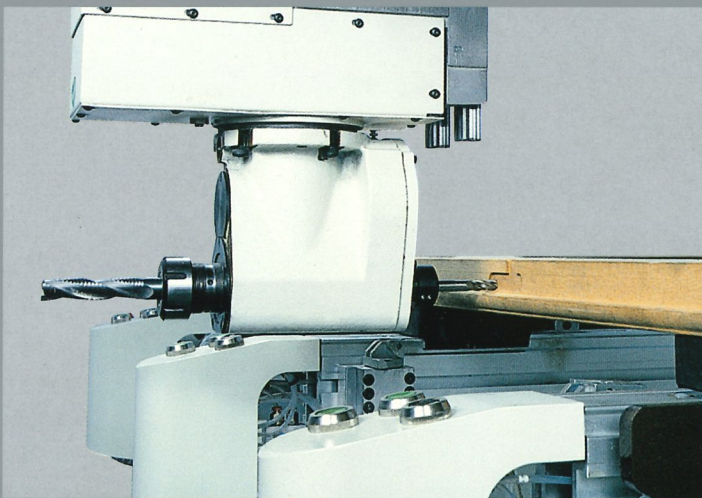
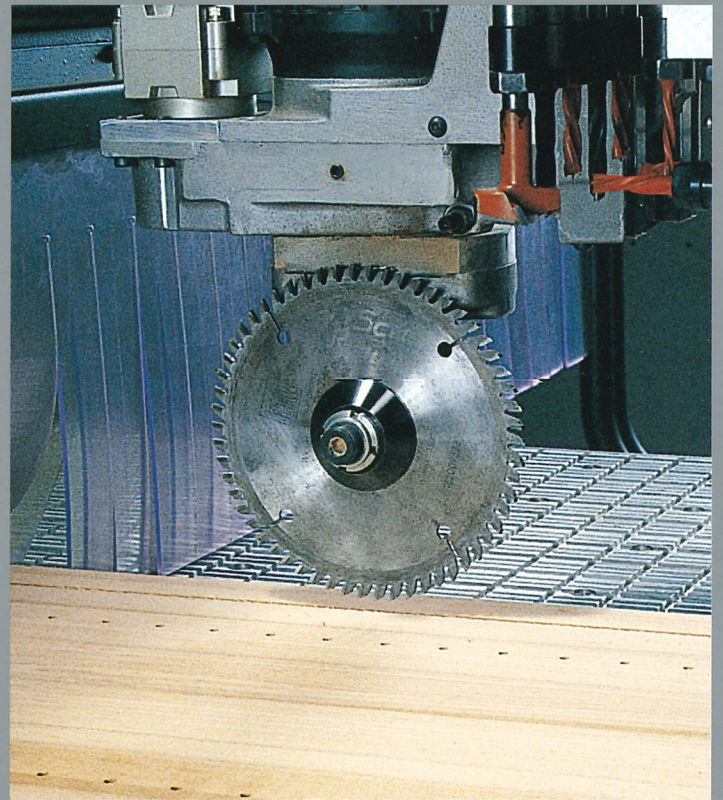

Fixed or CNC controlled Universal K2 unit for horizontal-axis machining.

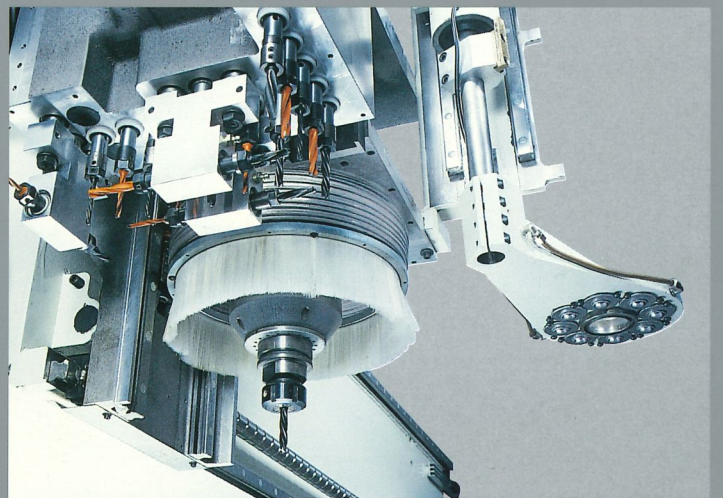

Mechanical presser with ball disk or chrome-plated disk.

Multifunction aluminium table

A solid base for all types of workpiece clamping

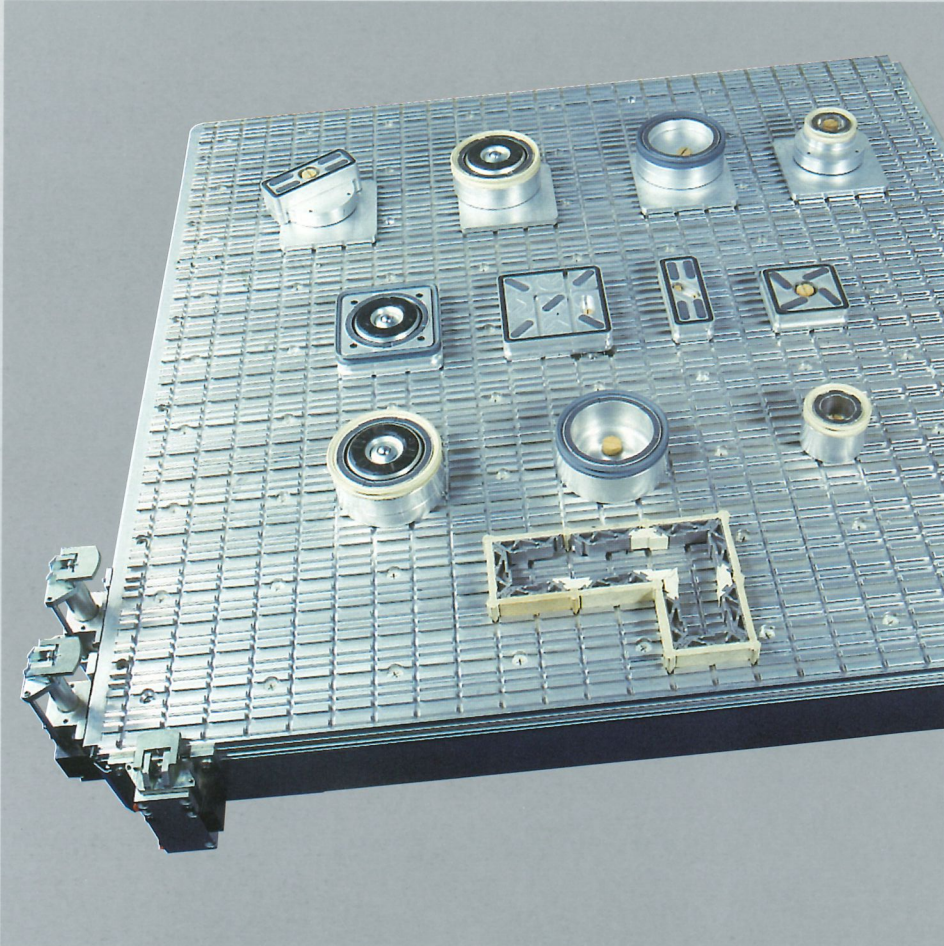

A full range of accessories designed to meet component support, clamping and referencing. Set-up times are drastically reduced.

MPS:
Set-up times reduced to the minimum.

The MPS system reduces your worktable set-up times to the bare minimum. When you insert the suction cups into the grooves of the worktable, an automatic valve starts the vacuum system immediately. Completely free of vacuum supply tubing, the MPS system is extremely easy to use. Using a laser positioning system that guides the operator in all positions the worktable set-up becomes simple, intuitive and straightforward.

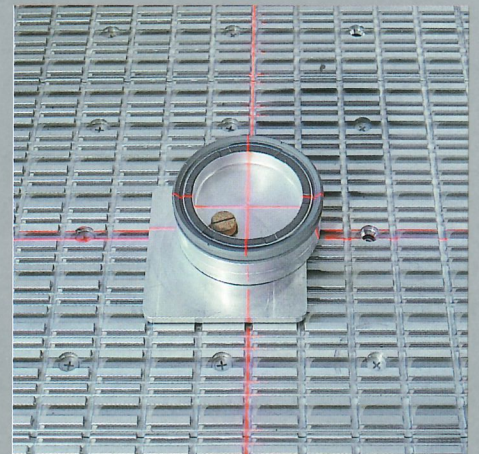
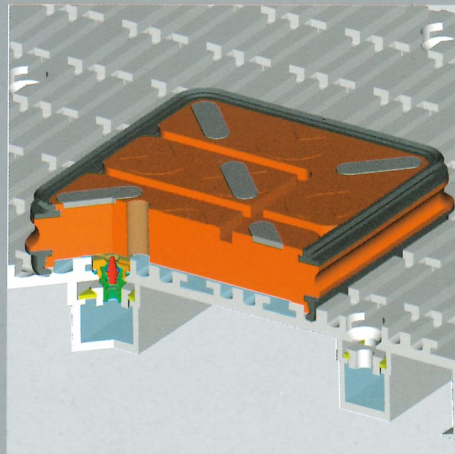

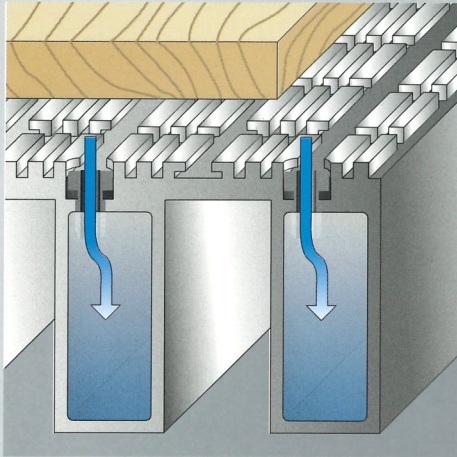
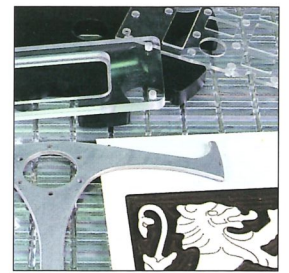

With its special aluminium profile, it guarantees total, long-lasting stability and a constant vacuum hold-down in every worktable area.



A solid base which offers a high vacuum capacity. The ideal worktable for component clamping.



Limitless hold-down capacity. This worktable is perfect for intensive applications – it will even hold down several overlapping panels. Another good way to increase your productivity.

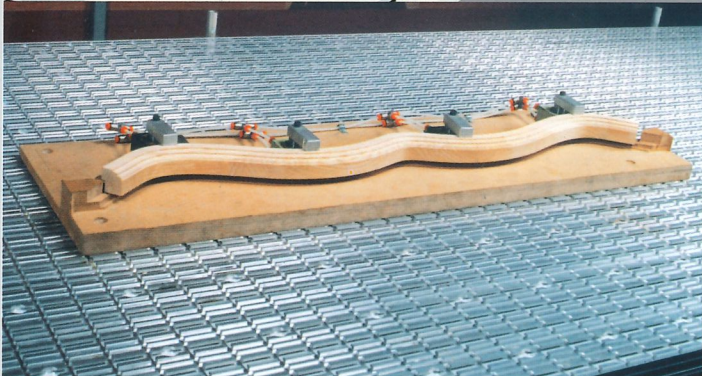

Special upside-down T-shaped grooves and threaded holes provide a perfect fixing for all hold-down devices.

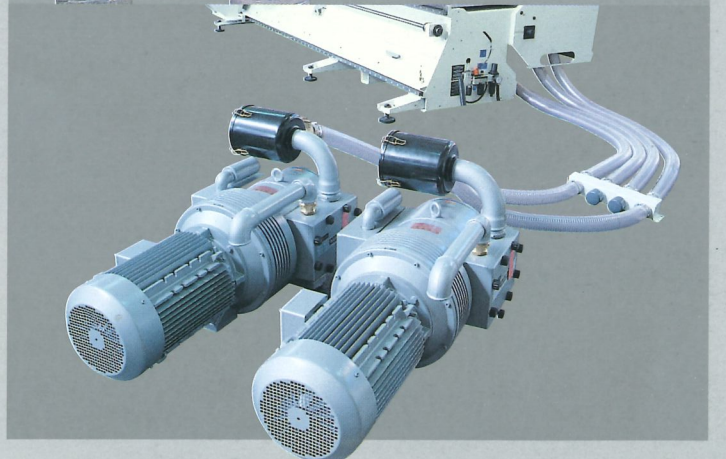
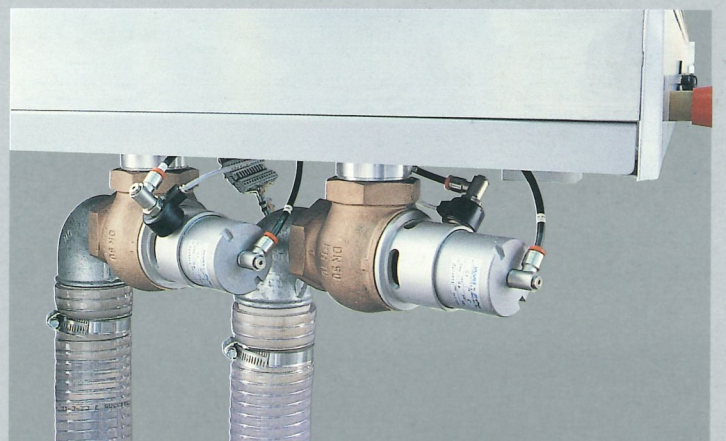

High capacity hold-down

The vacuum pumps and circuits are the ideal size for a high hold-down capability, even under heavy-duty operating conditions.

Nesting production cell: perfect integration

Maximum productivity
and total integration.



For industrial applications, Record 125 can be integrated with an automatic panel handling system to create a truly integrated machining cell.

Designed for the Nesting process, this cell combines high automated production levels with the flexibility of Nesting.

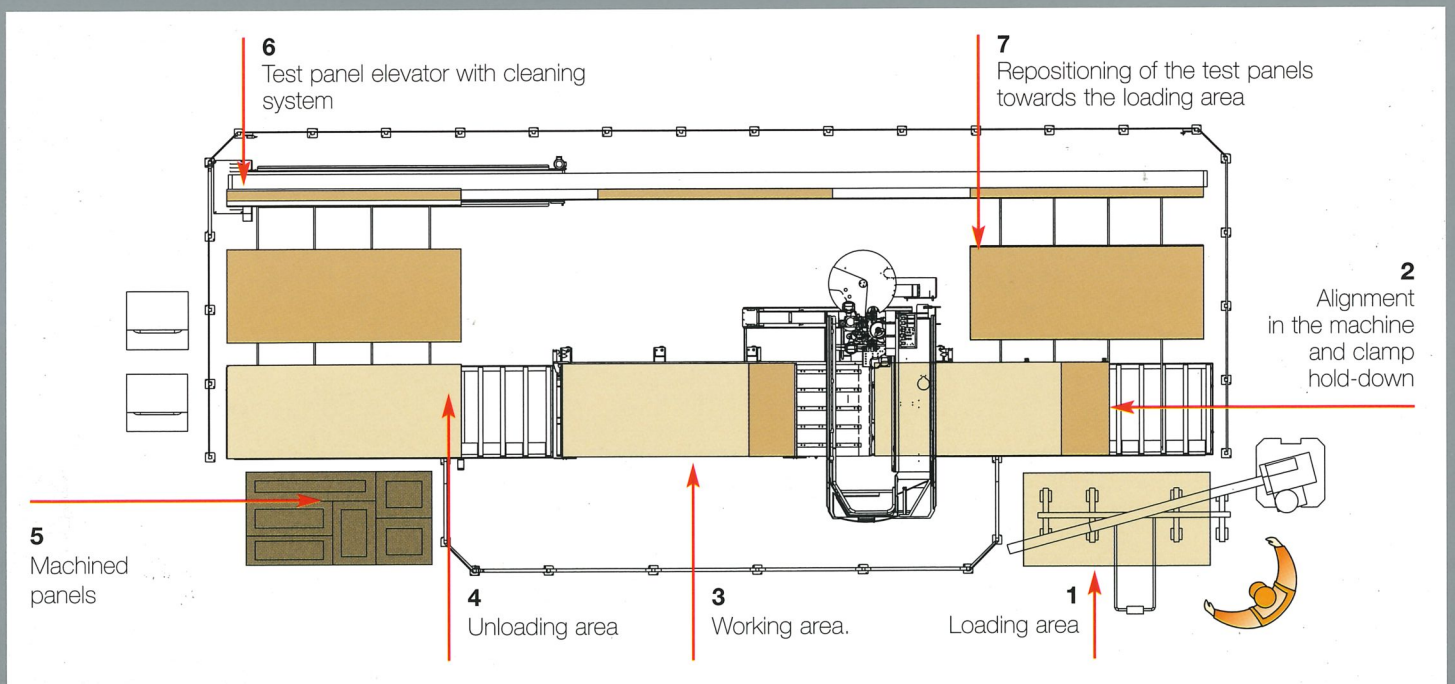

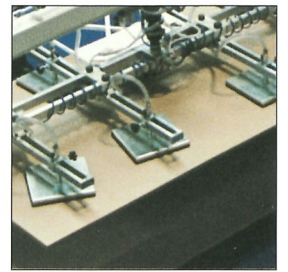

Loading area



Automatic infeed



Inversion of the vacuum flow: the panels float on an air cushion and are ejected.



Machined panels unloading area.



Rear test panel return.

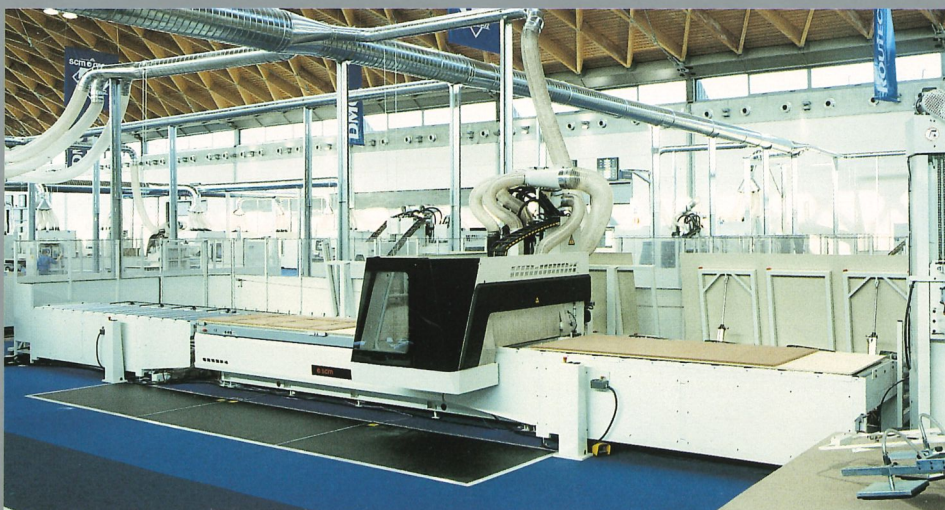

Perfect online integration to allow Record 125 to operate at its full capacity: the panels loaded on the loading roller are fed into the machine. When they have been machined, they are then pushed by new panels, loaded in infeed area, towards the unloading area. After machining, the test panels are cleaned again and sent automatically back to the loading area.

Xilog Plus PC OFFICE and CNC ISO

Easy-to-use, open to CNC world,
calculation power.

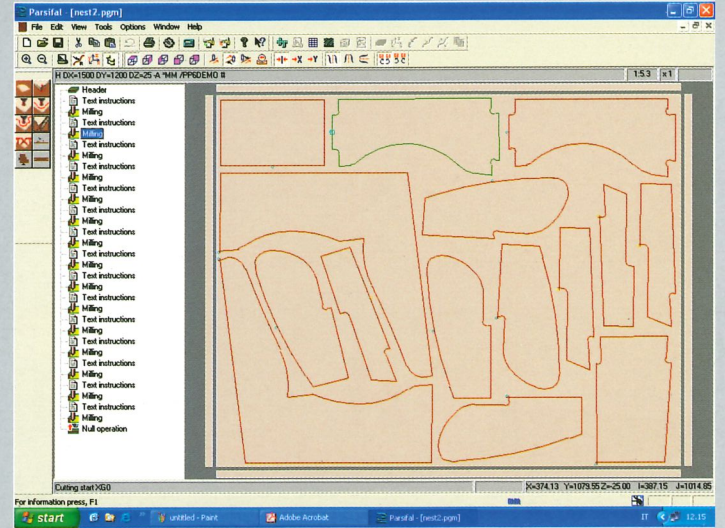
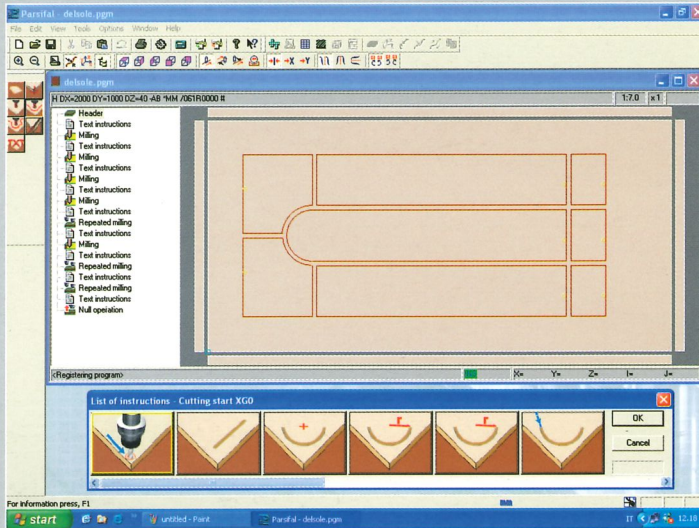
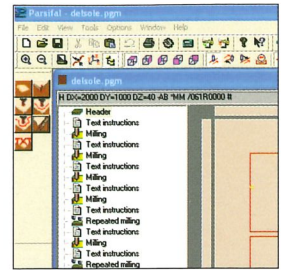

Operator interface with graphics to make machine programming and control even easier.

- Machine functions handled using a practical and fast control panel
- Programs can be generated even without deep technical knowledge using an Editor with graphical icons and examples on films. Completely realized using Windows operating system.

- Can be configured according to machining needs and enables a mode-guided, graphics or ISO programming.
- Can easily be integrated with external CAD-Cam packages or other CAD software by direct importing of DXF files (just drag a DXF file into the Xilog Plus window in order to get in real time the DXF geometries for the workpieces to be machined).
- Graphical display of tool parameter input
- The tools loaded on the machine are then completely handled by the software for tool cycle optimisation.



CNC and PC OFFICE

A high-power CNC on an office PC with a Windows interface. A cost-effective solution combining high-power processing and ease-of-use. The perfect combination at last.

This solution means you can use the CNC for all the functions normally handled by a PC:

- Internal company network connections
- All kinds of PC applications
- Adding data from a floppy disk or CD-ROM and remote connections.

TELESOLVE

A remote diagnostics system which allows the SCM assistance service technicians to operate on the machine in real time for:

- PLC logic diagnostics, machine parameter diagnostics, etc.
- Real-time updating of the CNC software.

Working area

Record
125

Record
125 N

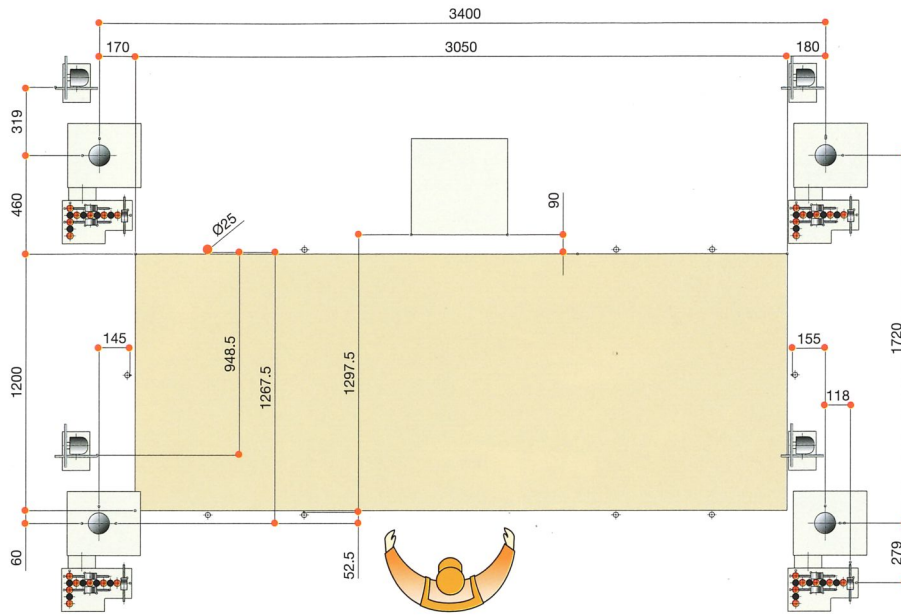

Record
125

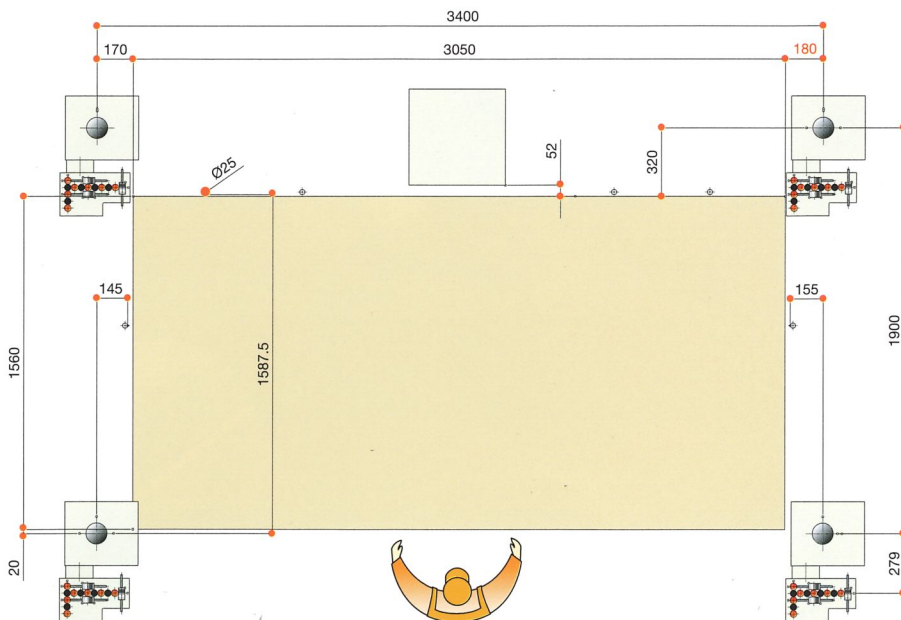

Record
125 N

Total safety
and security,
what you
should expect

Noise levels

Record 125	No-load operation without extraction	Machining
Average noise level on measurement surface dB (A)	67,7	81,8
Emitted noise level dBW (A) [mW (A)]	86,7 [0,5]	100,8 [12,0]
Noise level at operator position dB (A) [dB max]	67,7	84,4 [91,0]

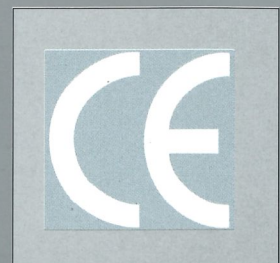

Overall dimensions

Record
125

Record
125 N

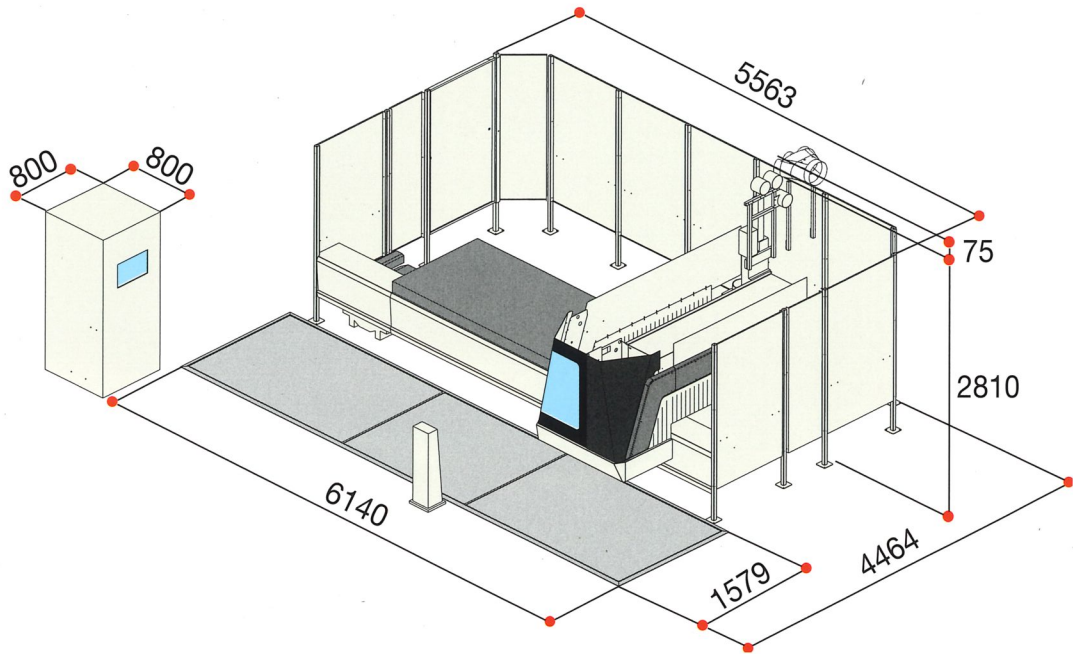

Record
125

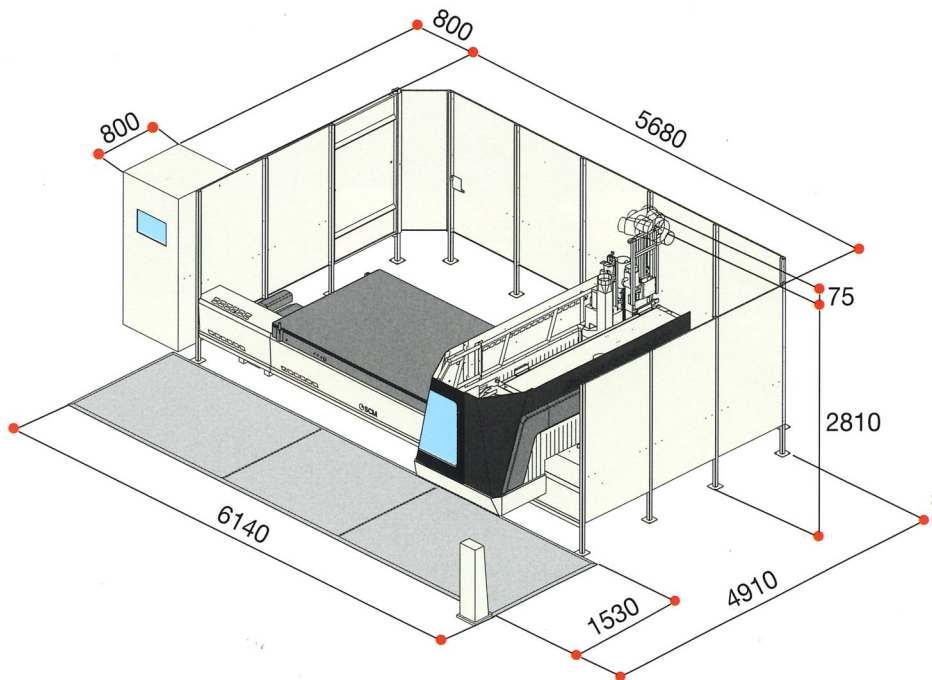

Record
125 N

Technical specifications

Component passage	310 mm
Axis speeds:	X = 80, Y = 55, Z = 25 m/min
Electro-spindle power:	7.5 kW (11 kW - 15 kW opt)
Routing unit tool capacity:	8 pos. - (12 pos opt)
Drilling unit:	9 - 18 spindles
Universal K2 unit:	3 kW fixed or CNC-controlled 0-360°
Saw blade unit	2.2 kW 0-90° or CNC-controlled 0-360°

In this catalogue, machines are shown with options. The firm reserves the right to modify technical specifications without prior notice, provided that such modifications do not affect safety as per E.C. certification.

Woodworking machinery: the widest range of products



SCM has been producing woodworking machinery for more than 50 years and represents the nucleus of SCM Group. With a total of 3000 employees, 15 factories and an export of 70%, this Group is one of the world's top producers of woodworking equipment. SCM produces the widest range of machines for secondary wood machining, from machines for small woodworking companies to CNC work centres, to high production integrated lines for the machining of solid wood. SCM is certified according to ISO 9001 Standards. Specialized technicians all over the world are able to supply an efficient and rapid after-sale service to SCM customers because full use is made of a system of remote computerised diagnostics. SCM can also utilize an internal structure of SCM Group, the CSR-Study and Research Consortium. CSR-Study and Research Consortium uses advanced experimental systems. This ensures that all machines satisfy the strictest international standards in terms of safety, ergonomics and environmental hygiene.

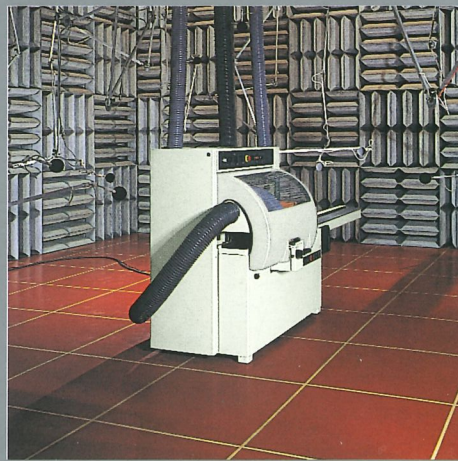

SE

ES

ES



SCM GROUP spa - Via Emilia, 71 - 47900 Rimini (RN) - Italy
Tel. +39/0541/700111 - Fax +39/0541/700181 - www.scmgroup.com - E-mail: scm@scmgroup.com