

**HOLZBEARBEITUNGSMASCHINEN**  
**WOODWORKINGMACHINES**

**BERNARDO®**

# FORMATKREISSÄGEN CIRCULAR SAWS

## BABY S 1

Schnittlänge 1800 mm, Gehrungsanschlag 900 mm,  
3,0 kW Motor

*Cutting length 1800 mm, mitre fence 900 mm,  
4,0 HP motor*



## S 1600 L

Schnittlänge 1900 mm,  
max. Schnitthöhe 103 mm, 3,0 kW Motor

*Cutting length 1900 mm,  
max. cutting height 103 mm, 4,0 HP motor*

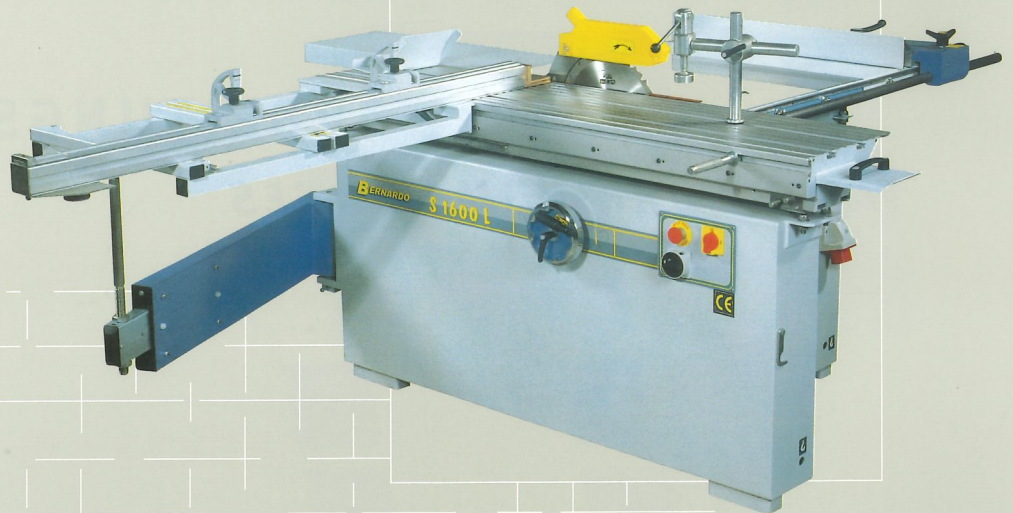

## S 2300 L

Schnittlänge 2600 mm,  
Sägeblattdurchmesser 315 mm, optimales  
Preis-Leistungsverhältnis

*Cutting length 2600 mm, saw blade diameter  
315 mm, optimal balance of price to efficiency*



# FORMATKREISSÄGEN CIRCULAR SAWS

## S 3000 L

Schnittlänge 3300 mm,  
Vorritzaggregat mit unabhängigem  
Motor, 4,0 kW Motor

*Cutting length 3300 mm, scoring unit with  
independent motor, 5,5 HP motor*

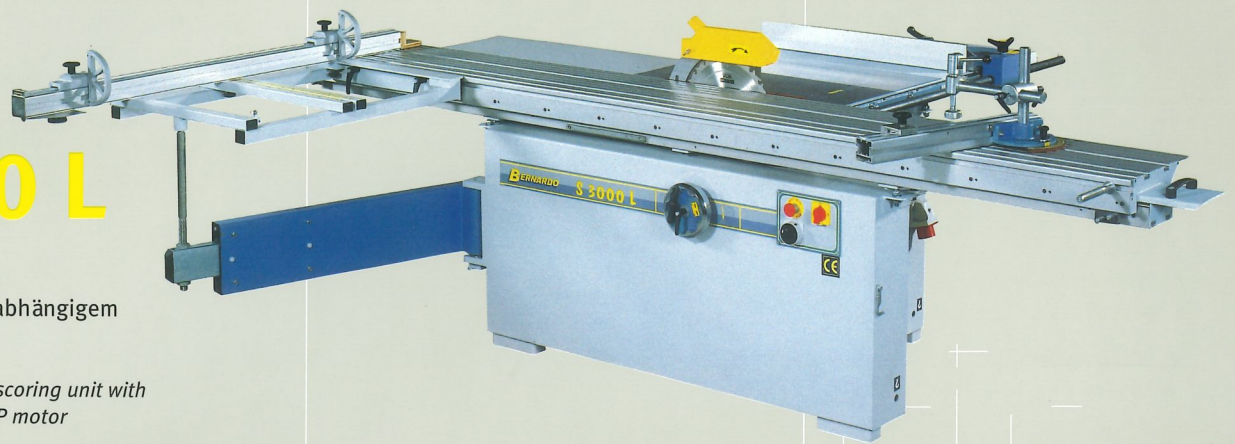

## SIRIUS 32 S

Schnittlänge 3450 mm,  
Schnitthöhe 117 mm, 7,5 PS Motor, 750 kg

*Cutting length 3450 mm, cutting height 117 mm,  
7,5 HP motor, 750 kg*

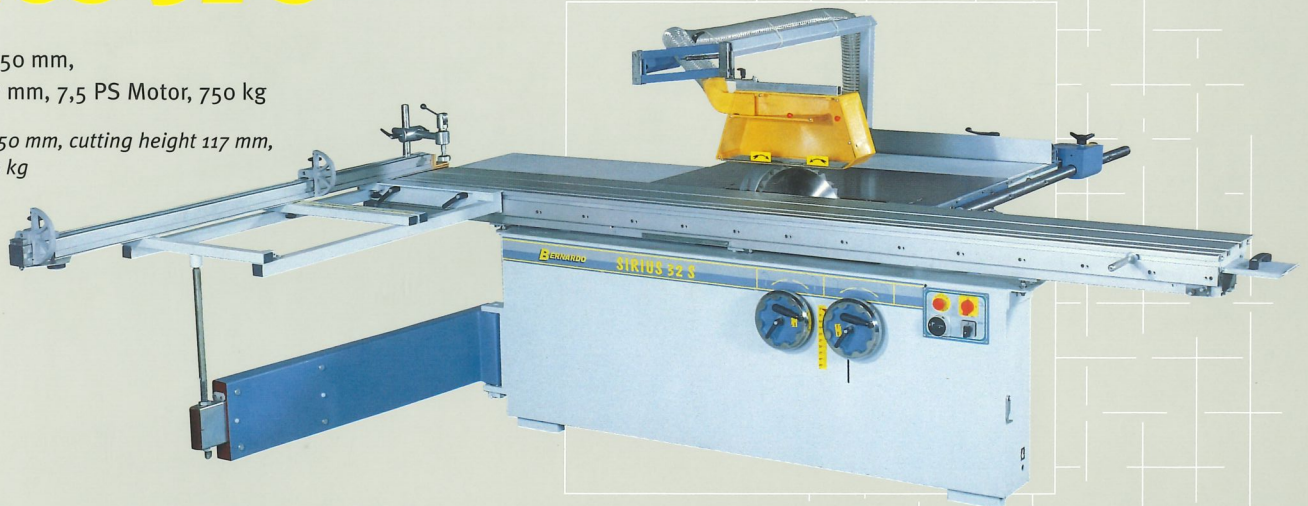

## S 400

Schnittlänge 3450 mm, 3 Spindeldrehzahlen,  
max Schnitthöhe 130 mm, Profiausführung

*Cutting length 3450 mm, 3 spindle speeds,  
max. cutting height 130 mm*

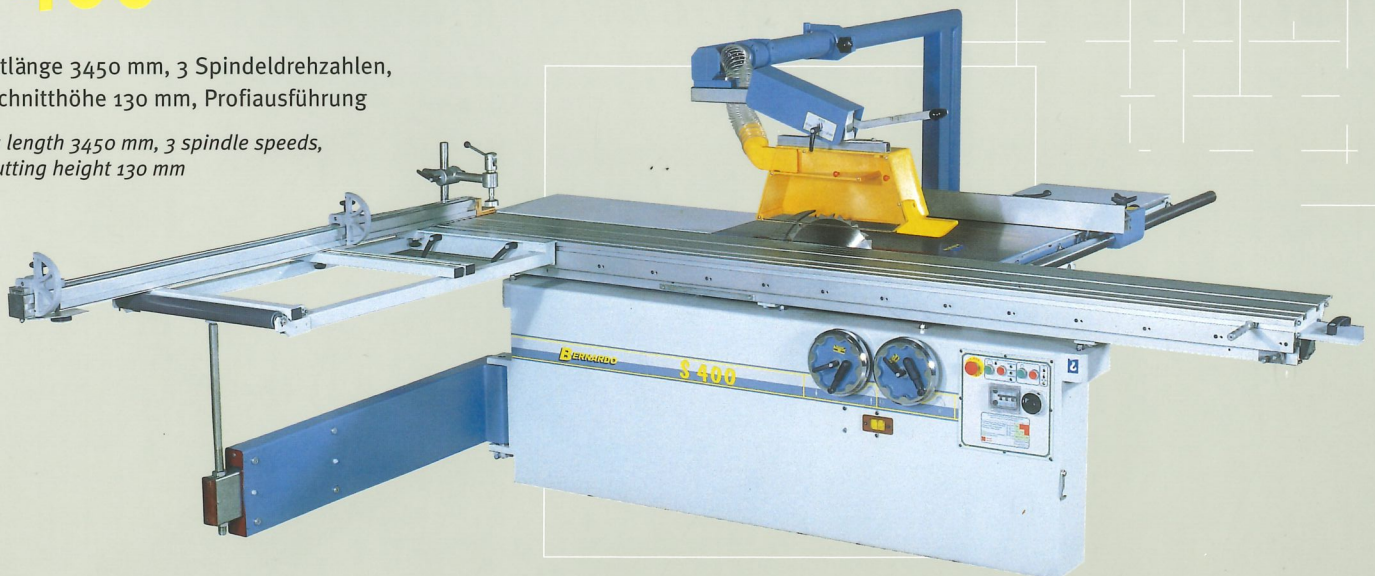

# KREISSÄGE-FRÄSMASCHINEN COMBINED CIRCULAR SAW & SPINDLE MOULDERS

## FK 2

Schwere Gußausführung, 2 Motore je 4,0 PS,  
Sägeblatt bis 45° schwenkbar

*Solid cast iron execution, 2 motors each 4,0 HP,  
tilting of saw blade up to 45°*

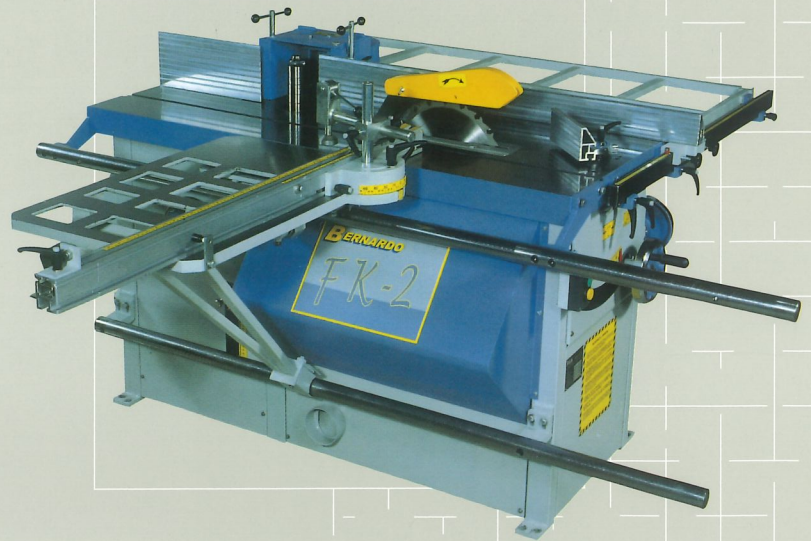

## SF 2300 L

Schnittlängen 1650 / 2350 / 3050 mm,  
4 Fräsgeschwindigkeiten, Sägeblatt  
bis 45° schwenkbar

*Cutting length 1650 / 2350 / 3050 mm,  
4 spindle speeds, saw blade tilting up to 45°*

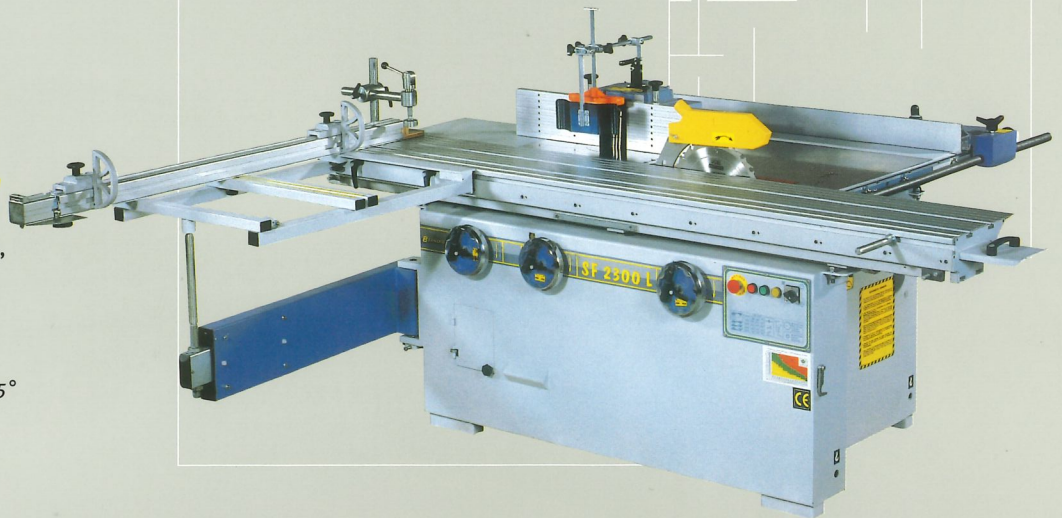

# UNIVERSAL-KOMBIMASCHINE UNIVERSAL COMBINED WOODWORKING MACHINE

## K5-320

Stabile Graugußausführung,  
3 Motore, 320 mm Hobelbreite,  
mit Langlochbohrereinrichtung

*Solid cast iron execution, 3 motors,  
planing width 320 mm, with mortiser*

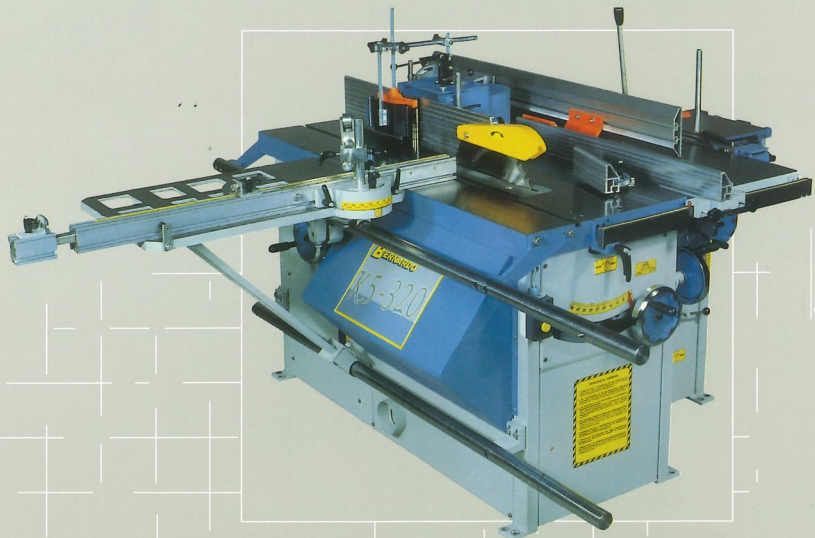

# UNIVERSAL-KOMBIMASCHINEN UNIVERSAL COMBINED WOODWORKING MACHINES

## K5-400

Hobelbreite 400 mm, max. Schnitthöhe 104 mm,  
Gewicht 1180 kg, viel Zubehör

*Planing width 400 mm, max. cutting height 104 mm,  
weight 1180 kg, much equipment*

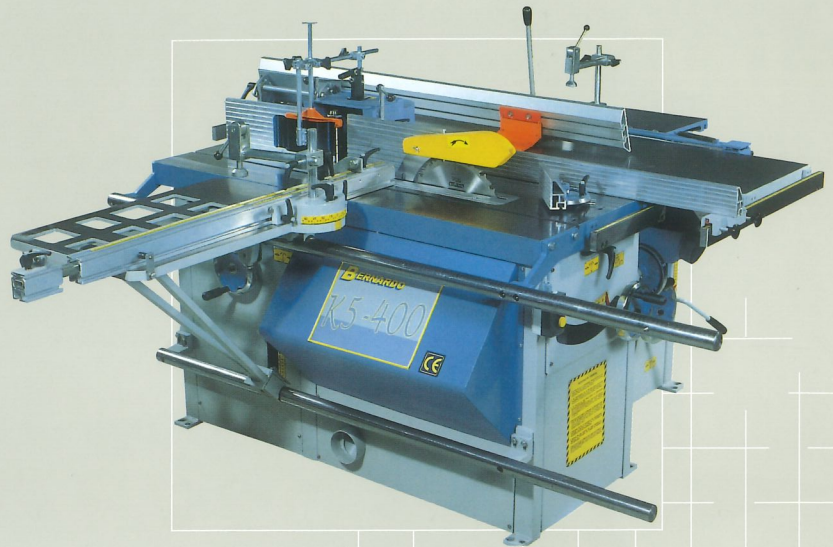

## CU 320 N

Formattischlänge 1600, 2300 und 3000 mm,  
3 Motore, Frässpindel nach hinten schwenkbar

*Sliding table length 1600, 2300 and 3000 mm,  
3 motors, spindle moulder tilting to the back side*



## CU 410 N

Hobelbreite 410 mm,  
3 x 5,5 PS Motore, 4 Fräsengeschwindigkeiten,  
Sägeblatt schwenkbar bis 45°

*Planing width 410 mm 3 x 5,5 HP motors,  
4 spindle speeds, tilting of saw blade up to 45°*

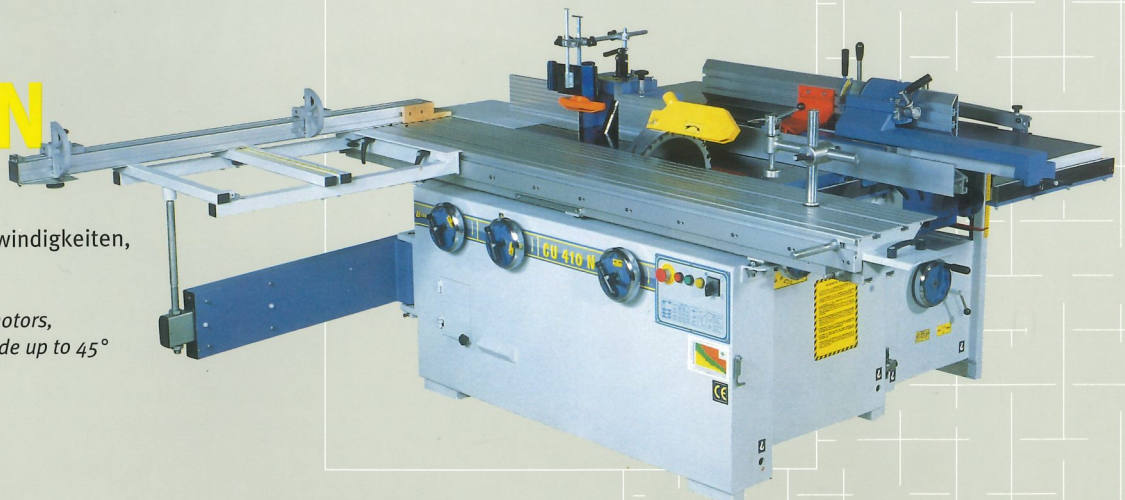

# ABRICHT- UND DICKENHOBELMASCHINEN SURFACE PLANER & THICKNESSERS

## ADM 320

Graugußausführung, Hobelbreite 320 mm, Durchlaßhöhe 230 mm, Motor 3,0 PS  
*Cast iron execution, planing width 320 mm, max. thicknesser height 230 mm, 3,0 HP motor*

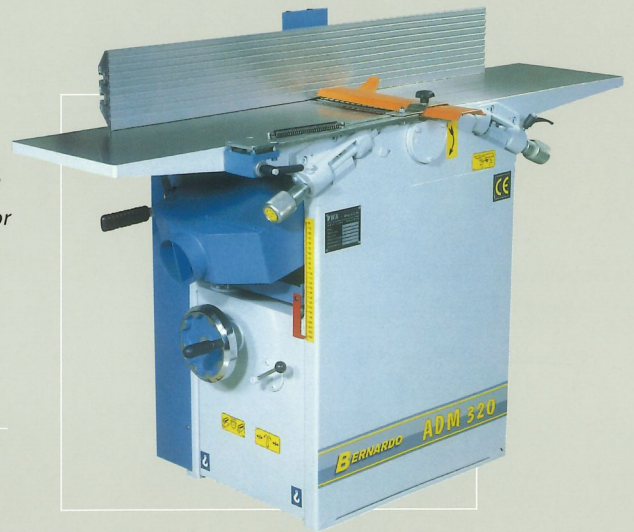
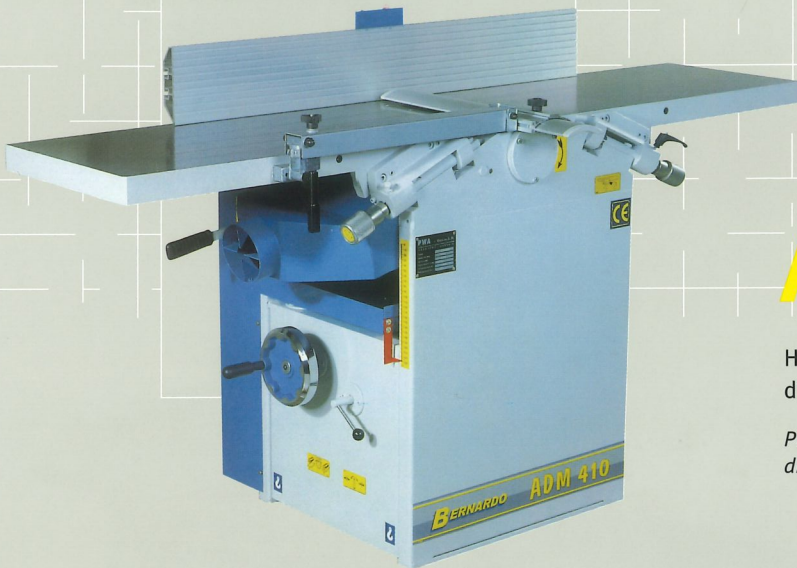

## ADM 410

Hobelbreite 410 mm, Motor 4,0 PS, 4-Messerwelle  
diam. 100 mm, Gewicht 400 kg

*Planing width 410 mm, 4,0 HP motor, 4-knife-cutterblock  
diam. 100 mm, weight 400 kg*

## FS 32 N

320 mm Hobelbreite, voreingestellte Wendehobelmesser,  
geschliffene Abrichttische, 360 kg

*Planing width 320 mm, pre-adjusted reversible cutter knives,  
planer tables with polished surface, 360 kg*

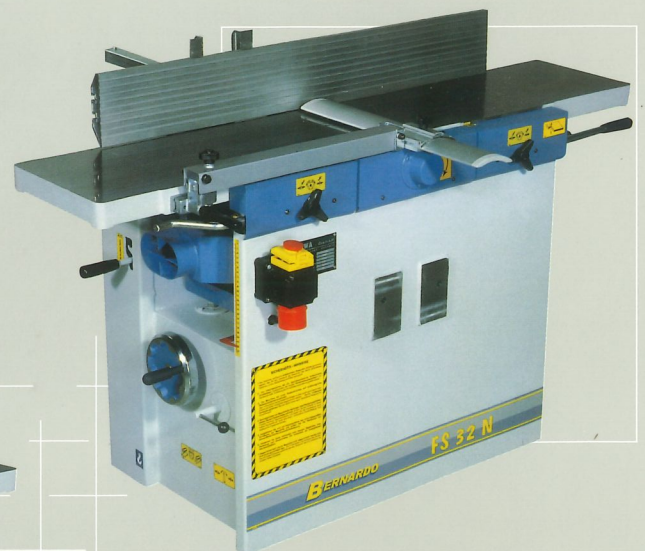

## FS 41 N

410 mm Hobelbreite, Motor 5,5 PS, Abrichttischlänge  
1800 mm, mit Dickentischwalzen, 420 kg

*Planing width 410 mm, 5,5 HP motor, length of tables 1800 mm,  
incl. thicknesser rollers, 420 kg*

# SCHWENKSPINDEL-FRÄSMASCHINEN SPINDLE MOULDERS

## T 800 i

Spindel schwenkbar  $-5^{\circ}$  bis  $+45^{\circ}$ , 4 Drehzahlen bis 8000 U/min,  
VARIO-Fräsanschlag, Gewicht 360 kg

*Tilting spindle  $-5^{\circ}$  to  $+45^{\circ}$ , 4 spindle speeds up to 8000 rpm,  
VARIO-moulding fence, weight 360 kg*



## T 1000 S

Formattisch 1150 mm, Frässpindel nach hinten (!) schwenkbar,  
Motor 7,5 PS, VARIO-Fräsanschlag mit Integral-Sicherheitsschienen

*Tenoning carriage 1150 mm, spindle tilting to the back side, 7,5 HP motor,  
VARIO-moulding fence with integral safety guides*

# LANGLOCHBOHRMASCHINE MORTISER

## LBM 200

Westcottbohrfutter 0 - 20 mm, schrägstellbare  
Bohrspindelgruppe, Motor 3,0 PS, Gewicht 180 kg,  
viele Optionen

*Westcott-chuck 0 - 20 mm, inclinable spindle group,  
3,0 HP motor, weight 180 kg, much options*



# KOPIERDRECHSELMASCHINEN WOODTURNING LATHES

## JUNIOR 1100

Spitzenweite 1100 mm, Spitzenhöhe 225 mm,  
4 Drehzahlen, inkl. Kopiervorrichtung, viel Zubehör

*Distance between center 1100 mm, height of center 225 mm,  
4 speeds, copying device, much equipment*

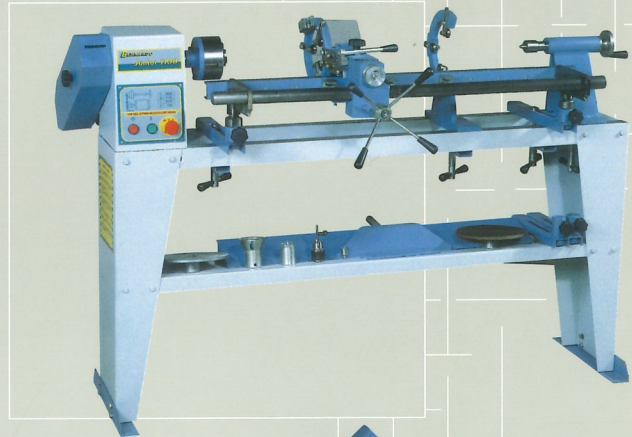

## CL 1200

Spitzenweite 1250 mm, Spitzenhöhe 220 mm,  
mit pneumatischer Andrückvorrichtung, Gewicht 370 kg

*Distance between center 1250 mm, height of center 220 mm,  
with pneumatical pressure device, weight 370 kg*

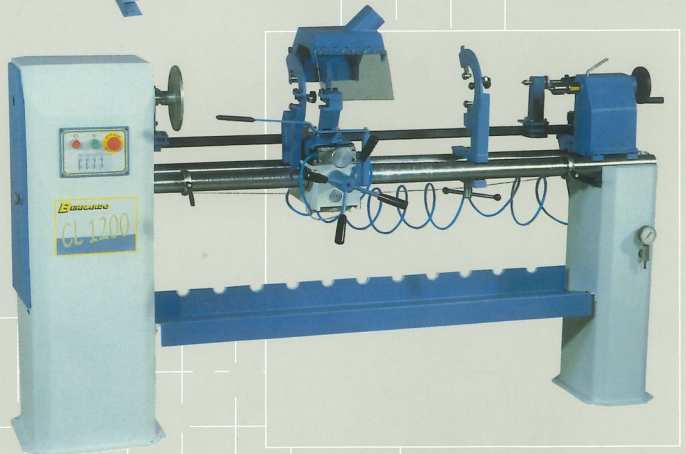

# HOLZBANDSÄGEN WOOD BANDSAWS



## HBS 450

Schnittbreite 440 mm, Schnitthöhe 270 mm,  
Tisch schwenkbar bis 45°,  
optimales Preis-Leistungsverhältnis

*Cutting width 440 mm, cutting height 270 mm,  
tilting table up to 45°, optimal balance of  
price to efficiency*



## HBS 450 S

Schnittbreite 440 mm, mit oberer  
und unterer Präzisionsführung,  
Motor 2,0 PS, Gewicht 160 kg

*Cutting width 440 mm, top and bottom  
precision blade guides, 2,0 HP motor,  
weight 160 kg*



## HBS 550 S

Schnittbreite 540 mm,  
Schnitthöhe 280 mm, stabile Stahl-  
Graugußkonstruktion

*Cutting width 540 mm,  
cutting height 280 mm, solid steel-  
and cast iron construction*



# KANTENSCHLEIFMASCHINEN

## EDGE SANDERS

### HV 80 OSZI

Mit Oszillation, Schleifband 2510 x 150 mm, Tisch höhenverstellbar, inkl. Radienschleiftisch

*With oscillation, belt dimension 2510 x 150 mm, table height adjustment, incl. supporting table*

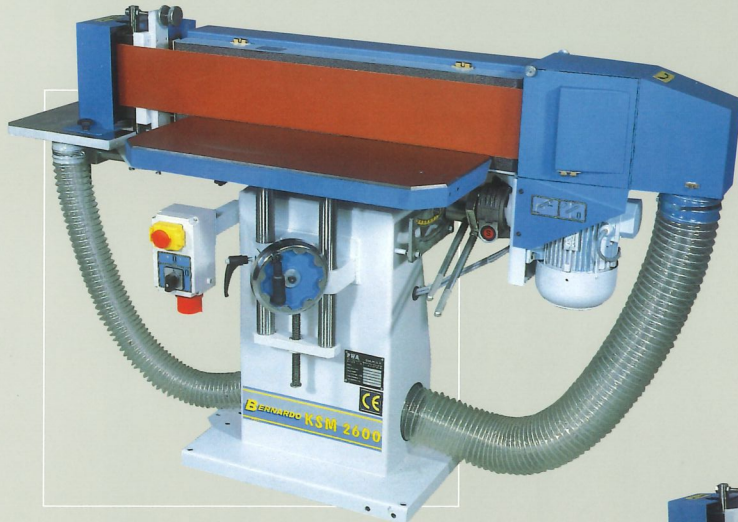

### KSM 2600

Mit Oszillation, Aggregat bis 45° schrägstellbar, Schleifband 2600 x 150 mm, Gewicht 180 kg

*With oscillation, sanding unit tiltable up to 45°, belt dimension 2600 x 150 mm, weight 180 kg*

### KSM 3000

Mit Furnierschleifeinrichtung, Oszillationshub 20 mm, Schleifband 3000 x 150 mm, Motor 4,0 PS

*With veneer sanding device, oscillation stroke 20 mm, belt dimension 3000 x 150 mm, 4,0 HP motor*

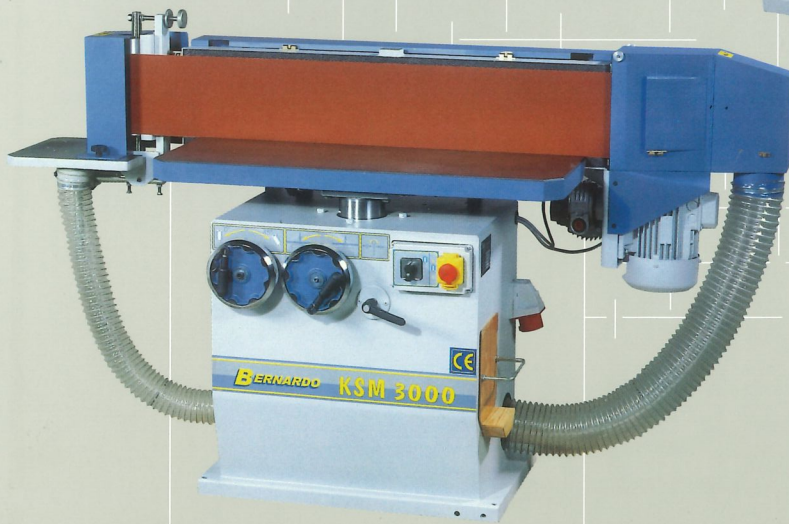

### KSM 3000 S

Schleifband 3000 x 200 mm, inkl. Oszillation, massive Ausführung, viele Optionen - Drehstern,....

*Belt dimension 3000 x 200 mm, with oscillation, solid execution, much options available*

# LANGBANDSCHLEIFMASCHINE BELT AND EDGE SANDING MACHINE

## PBVN 2400

Schleiflänge 2000 / 2400 mm,  
auch als Kantenschleifmaschine einsetzbar

*Table length 2000 / 2400 mm,  
possible to use as an edge sander*

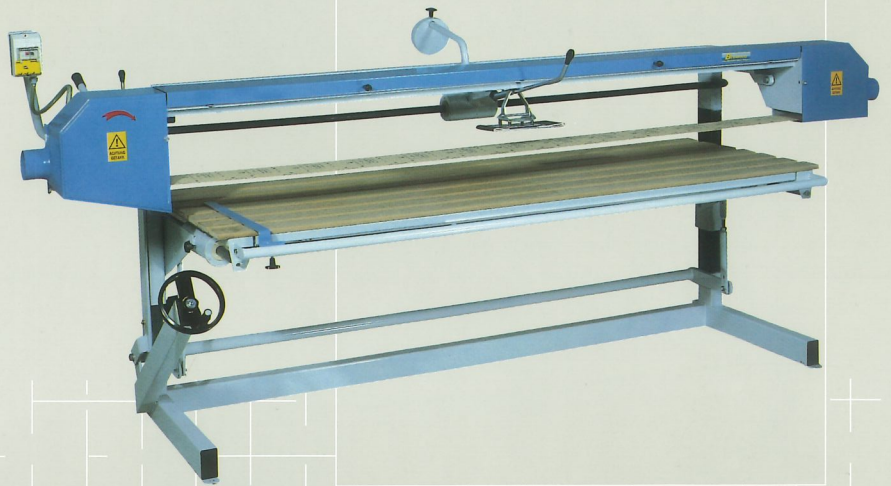

# VERLEIMSTÄNDER VERTICAL EDGE CLAMPING PRESS

## HVS 30/20

Spannbereich 2800 x 1360 mm,  
4 verschiebbare Druckzylinder, 1 Druckbügel

*Clamping area 2800 x 1360 mm,  
4 flexible pressing beams, 1 front clamp*



# RAHMENPRESSE FRAME PRESS

## HRP 30/20

Spannbereich 2800 x 1360 mm, Zylinder mit  
2000 kp Druckkraft, universell einsetzbar

*Clamping area 2800 x 1360 mm, cylinder with 2000  
kp pressure force, universal to use*

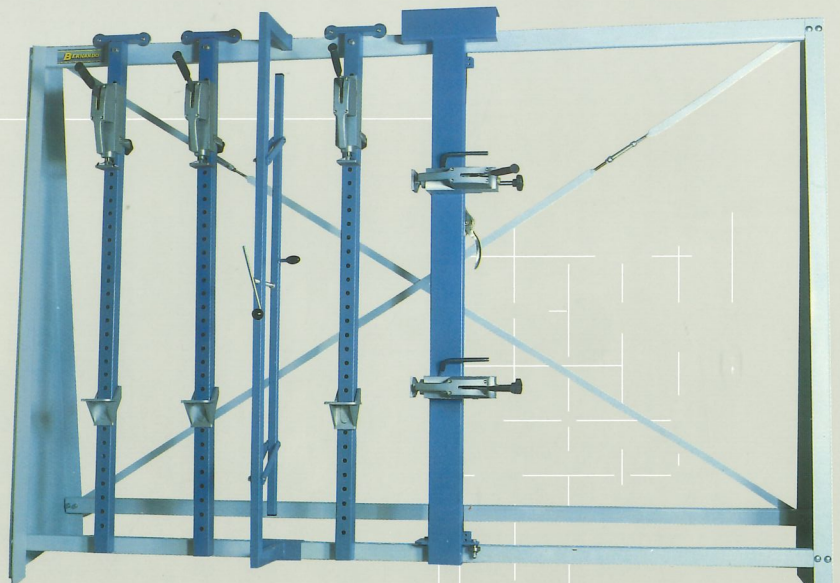

# VIERSEITENHOBELMASCHINE FOUR-SIDE PLANER

## COMPACT 18 S

Hobelbereich 180 x 120 mm,  
4 Spindeln, Tischlänge 1700 mm,  
Gesamtleistung 16,1 kW

*Dimension of workpiece  
180 x 120 mm, 4 spindles,  
length of table 1700 mm,  
total power 22,0 HP*

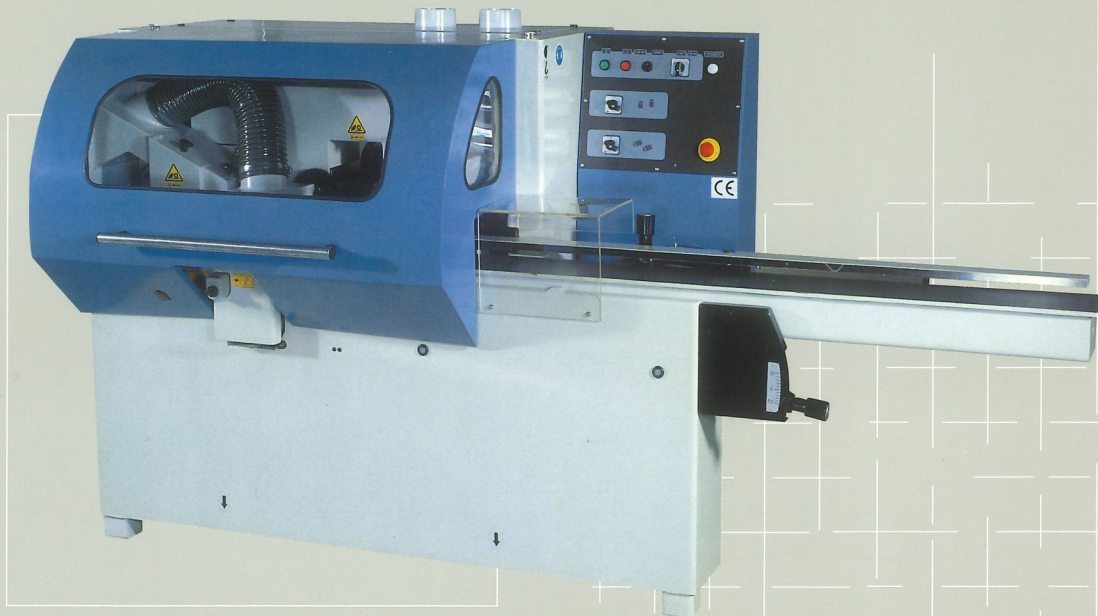

# VIERSEITENHOBEL- UND PROFILIERMASCHINE FOUR-SIDE PLANER AND MOULDER

## QUADROPROFILER 18 S

Hobelbereich 180 x 120 mm,  
Werkzeugdurchmesser bis 180 mm,  
Gesamtanschluß 20,0 kW

*Dimension of workpiece 180 x 120 mm,  
diameter of cutterhead up to 180 mm,  
total power 27,0 HP*

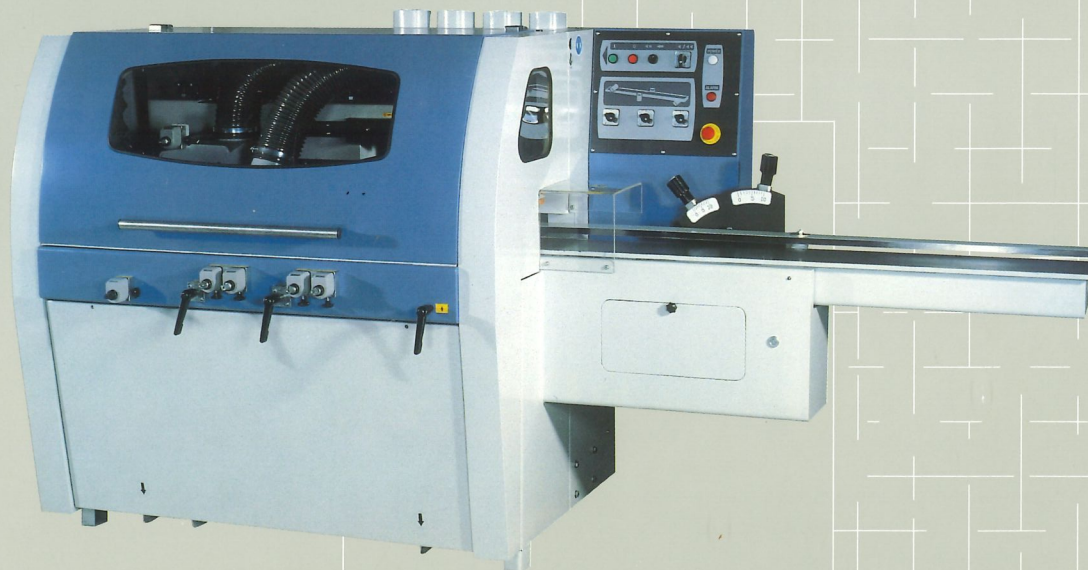

# RADIALVENTILATOREN RADIAL COLLECTORS

## SDC-1241

Saugleistung 1100 m<sup>3</sup>/h, Motor 0,55 kW, 22 kg

Capacity 1100 m<sup>3</sup>/h, 0,75 HP motor, 22 kg



## RV 305

Saugleistung 3000 m<sup>3</sup>/h, Motor 3,0 PS, für Wandmontage geeignet, Gewicht 40 kg

Capacity 3000 m<sup>3</sup>/h, 3,0 HP motor, weight 40 kg



## RV 403

Saugleistung max. 5800 m<sup>3</sup>/h, Motor 3,0 PS, Ansaugdurchmesser 250 mm, 43 kg

Capacity max. 5800 m<sup>3</sup>/h, 3,0 HP motor, inlet diameter 250 mm, 43 kg

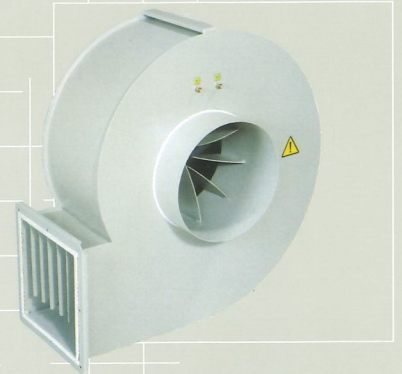

# ABSAUGUNGEN DUST COLLECTORS



## DC 300

Spänesackinhalt 200 l, Saugleistung 2000 m<sup>3</sup>/h, Motor 2,0 PS, optimales Preis-Leistungsverhältnis

Waste sack volume 200 l, capacity 2000 m<sup>3</sup>/h, 2,0 HP motor, opt. balance of price to efficiency



## DC 500

Spänesackinhalt 2 x 150 l, Saugleistung 3200 m<sup>3</sup>/h, Motor 3,0 PS, Stahllüfterrad, fahrbar

Waste sack volume 2 x 150 l, capacity 3200 m<sup>3</sup>/h, 3,0 HP motor, steel fan, portable



## FT 202

Saugleistung 1700 m<sup>3</sup>/h, Spänesackinhalt 2 x 120 l, Motor 1,5 PS, fahrbar

Capacity 1700 m<sup>3</sup>/h, waste sack volume 2 x 120 l, 1,5 HP motor, portable

# ABSAUGUNGEN DUST COLLECTORS



## FT 302

Saugleistung 3600 m<sup>3</sup>/h,  
Spänesackinhalt 2 x 210 l, Motor 1,5 PS

*Capacity 3600 m<sup>3</sup>/h,  
waste sack volume 2 x 210 l, 1,5 HP motor*



## FT 400

Saugleistung 4600 m<sup>3</sup>/h,  
Spänesackinhalt 2 x 330 l, Motor 3,0 PS

*Capacity 4600 m<sup>3</sup>/h,  
waste sack volume 2 x 330 l, 3,0 HP motor*



## FT 403

Spänesackinhalt 1000 l,  
Saugleistung 5800 m<sup>3</sup>/h, Gewicht 85 kg

*Waste sacks volume 1000 l,  
capacity 5800 m<sup>3</sup>/h, weight 85 kg*



## FT 404

Spänesackinhalt 1320 l, Saugleistung 5800 m<sup>3</sup>/h,  
Stahllüfterrad, Gewicht 95 kg

*Waste sacks volume 1320 l, capacity 5800 m<sup>3</sup>/h,  
steel fan, weight 95 kg*



## FT 504

Saugleistung 8700 m<sup>3</sup>/h, Spänesackinhalt 1320 l,  
Motor 4,0 PS Gewicht 171 kg

*Capacity 8700 m<sup>3</sup>/h, waste sacks volume 1320 l,  
4,0 HP motor, weight 171 kg*

# VORSCHUBAPPARATE POWER FEEDERS

## BABY M3

Rollenabmessung 76 x 30 mm,  
Geschwindigkeit stufenlos  
2-12 m/min

*Roller size 76 x 30 mm,  
stepless feeding speed 2-12 m/min*

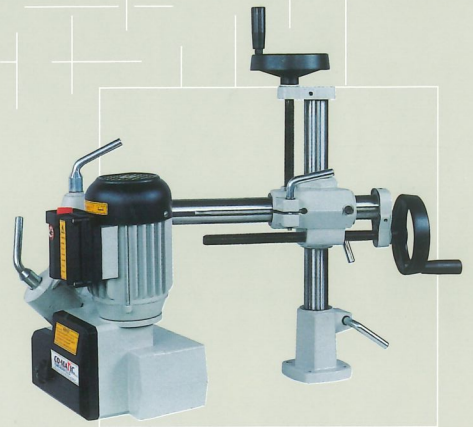

## AF 32

Rollenabmessung 80 x 30 mm, 4 Geschwindigkeiten, Gewicht 34 kg

*Roller size 80 x 30 mm, 4 feeding speeds, weight 34 kg*

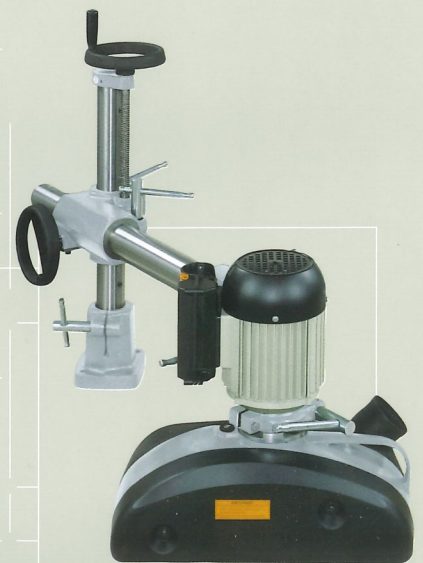
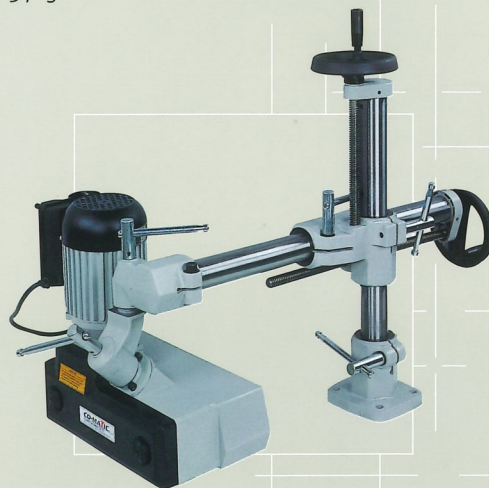

## AF 308

Rollenabmessung 100 x 50 mm,  
8 Geschwindigkeiten, Motor 0,5 PS

*Roller size 100 x 50 mm,  
8 feeding speeds, 0,5 HP motor*

## MX 38

Rollenabmessung 120 x 60 mm, 8 Geschwindigkeiten, Motor 1,0 PS,

*Roller size 120 x 60 mm, 8 feeding speeds, 1,0 HP motor*

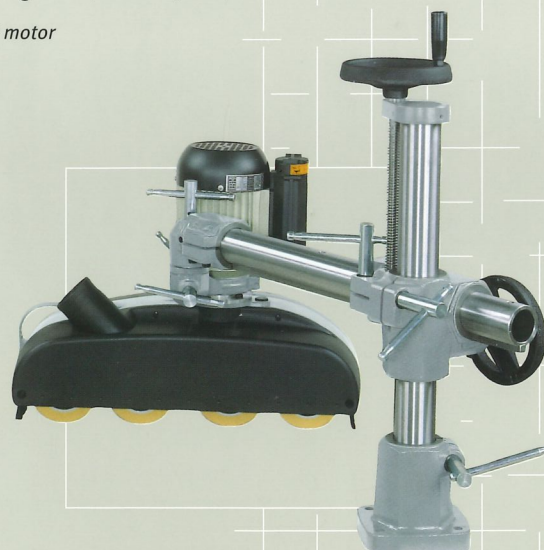

## MX 48

Rollenabmessung 120 x 60 mm,  
8 Geschwindigkeiten, 4 Vorschubrollen

*Roller size 120 x 60 mm,  
8 feeding speeds, 4 rollers*

**HOBELBANK  
WORK BENCH**

**BHB 2100 UB**

Arbeitstisch 2100 x 680 mm,  
Gewicht 127 kg, erstklassige Ausführung  
aus gedämpftem Rotbuchenholz

*Table dimension 2100 x 680 mm,  
weight 127 kg, first class execution made  
from hushed red beech-tree*



**BAND-UND TELLERSCHLEIFER  
BELT AND DISC SANDER**

**BDSM**



Schleifband 100 x 915 mm, inkl. Gehrungsanschlag,  
Auflagetisch winkelverstellbar

*Belt dimension 100 x 915 mm, incl. mitre fence,  
disc table tilts 45°*

**DEKUPIERSÄGE  
SCROLL SAW**

**SSM**

Ausladung 405 mm, max. Schnitthöhe 50 mm,  
Graugußtisch schwenkbar, Gewicht 17 kg

*Throat 405 mm, max. thickness of cut 50 mm,  
cast iron table tilt 0° - 30°, weight 17 kg*

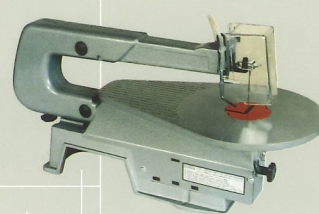

**DRECHSELMASCHINE  
WOODTURNING LATHE**

**KDM 900**



Spitzenweite 1100 mm, Drehzahlen stufenlos  
verstellbar, Maschinenbett aus Grauguß

*Distance between center 1100 mm, stepless speeds  
up to 2000 rpm, solid cast iron bed*

**HOLZBANDSÄGE  
WOOD BANDSAW**

**BS 320**

Ausladung 305 mm, Schnitthöhe 160 mm,  
2 Geschwindigkeiten, Graugußtisch, Gewicht 70 kg

*Throat 305 mm, cutting height 160 mm, 2 speeds,  
cast iron table, weight 70 kg*



**ABRICHT- UND  
DICKENHOBELMASCHINE**

**SURFACE PLANER & THICKNESSER**

**ADM 260**

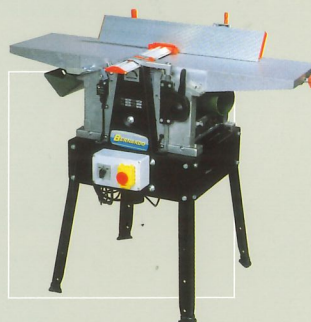

Hobelbreite 260 mm, Abrichttischlänge  
1000 mm, Motor 1,5 PS ( 230 V )

*Planing width 260 mm, length of tables 1000 mm,  
1,5 HP motor (230 V)*

**HUBWAGEN  
HAND PALLET TRUCK**

**PHW 2,5 P**

Tragkraft 2,5 to, Gabellänge 1100 mm,  
Polyurethanräder, Feinabsenkenventil

*Lifting capacity 2,5 to, fork length 1100 mm,  
polyurethan wheels*



