



TURBO-Drive

The latest in ultrafast technology

Cross-sections from 20 x 40 mm to 160 x 450 mm

Innovation in timber engineering



Hundegger TURBO-Drive. It's all about speed and versatility. And speed.



Cutting without measuring or set-up

We know how seriously you take your business. That's why we're just as passionate about ours. Hundegger is the world's leading manufacturer of Wood Component equipment. From post and beam timbers to webs and chords we build our machines for durable performance that exceeds the expectations of the wood construction market. We introduce innovations aimed specifically at reducing your costs and maximizing your throughput. Our products are built to provide solutions for all types and sizes of components and we are backed by the commitment to exceed expectations in service and support.

To achieve maximum throughput, you need maximum performance. The TURBO-Drive machine is the perfect solution when speed and versatility are required. We continue to provide innovative options including basic drilling, milling and printing operations like nothing else on the market.

As opposed to alternative solutions, the TURBO-Drive saw blade is able to move below the zero line and to a 90° bevel, making it possible to cut horizontal and at an angle.



For even more Versatility

The TURBO-Drive can be equipped with up to two optional vertical mill units.

Options include either a 7.5 kW milling and drilling unit for milling recesses or profiles as well as a 2.2 kW drill unit.

These vertical mill can help process unique milling operations on single parts or on stacked parts.



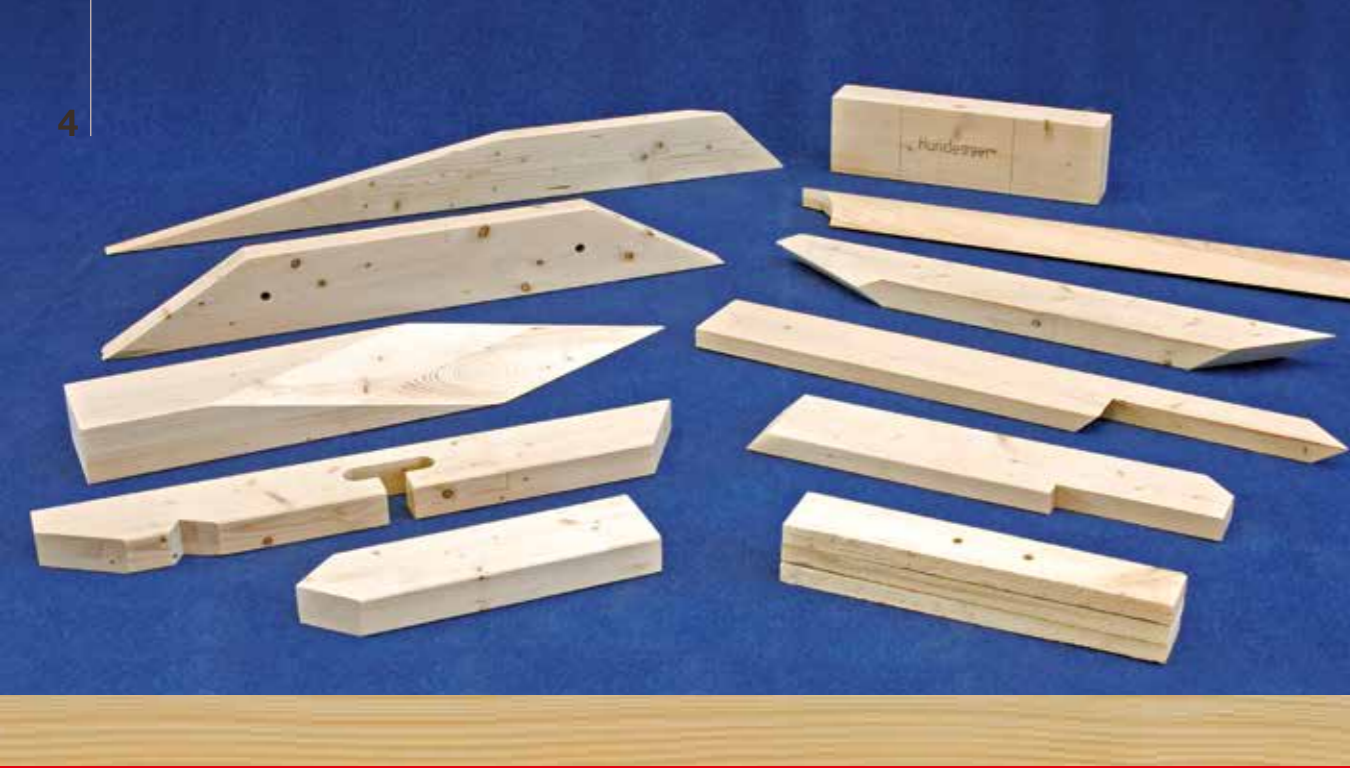

HUNDEGGERS LATEST PRODUCTION SOFTWARE - CAMBIUM



For identification and marking of the finished parts, the TURBO-Drive can be installed with an inkjet marking system as well as marking pen or a label printer options.



From a simple lay-out lines to multiline text or bar codes, most all marking options are available and can be added.

Data can be transferred directly into the TURBO-Drive software from most design software's.



Every component manufacturer needs equipment that can be trusted for long-lasting performance. But it must get jobs done on time and on budget. For maximum throughput the automation of the TURBO-Drive can be further enhanced with an In-feed system. The user can place several boards on the loading conveyor. These boards are then automatically fed to the TURBO-Drive and through the machine accurately and efficiently. Such ease of use means the operator can concentrate on other tasks while the machine takes care of the processing. A cross conveyor system is available at the out feed of the machine for collecting and sorting the finished parts.

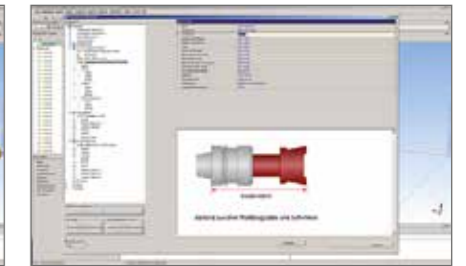
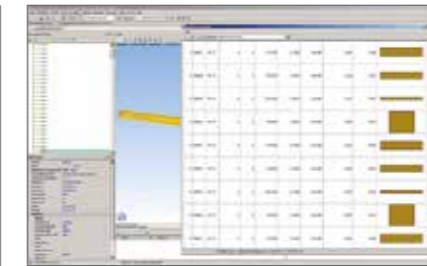

Machine is supplied complete with all required software

Even the best mechanical system is only as good as the corresponding software. For this reason Hundegger places great importance on our in-house software development department.

This results in solutions which can be customized to customer requirements and constantly updated. Our customers benefit from this development for many years to come as regular free software updates are continually offered.

The new Hundegger 3D production program CAMBIUM is characterized by its simple, friendly, timber construction orientated input methods meaning ultimate operator convenience.

By demand, CAMBIUM is the latest software that allows Data to be used by planning engineers, production managers, etc.

A unique tool that can assist in processing strategies is available in the CAMBIUM program. It is being used to adjust the settings of the machine to adapting to the user defined quality and speed.

The software is an open architecture format for easy integration of the Hundegger machine into company Networks for a comprehensive reporting capability of production data and a remote diagnostics / maintenance System.

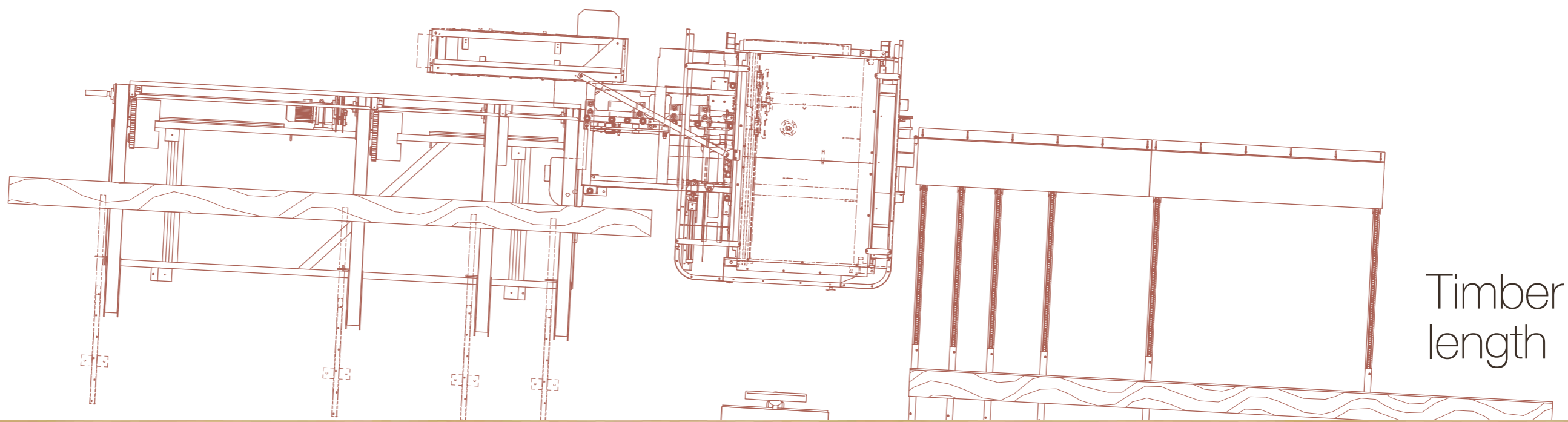

Timber length

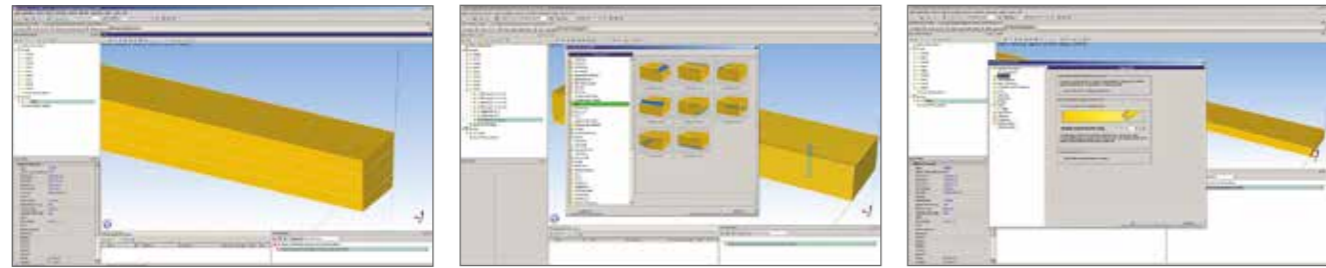

Board stretcher
cutting-edge technology and unmatched efficiency

Without Board stretcher 6,60 m

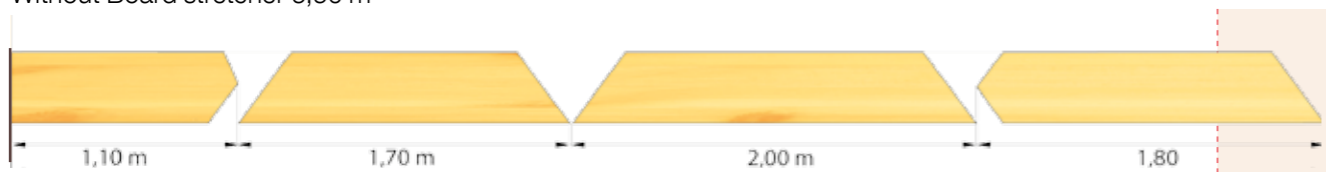

With Board stretcher 6,00 m

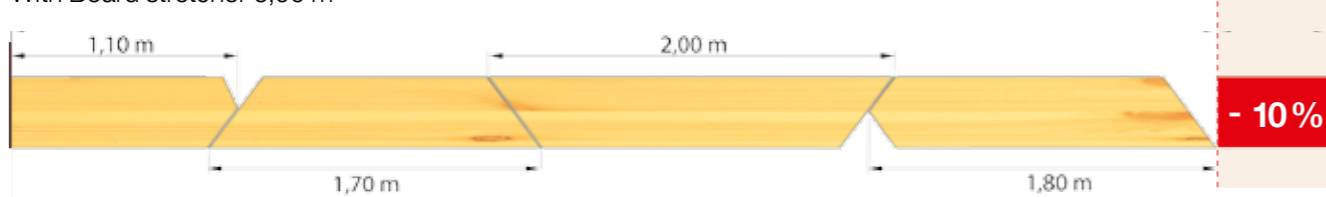

Less timber consumption = more benefit

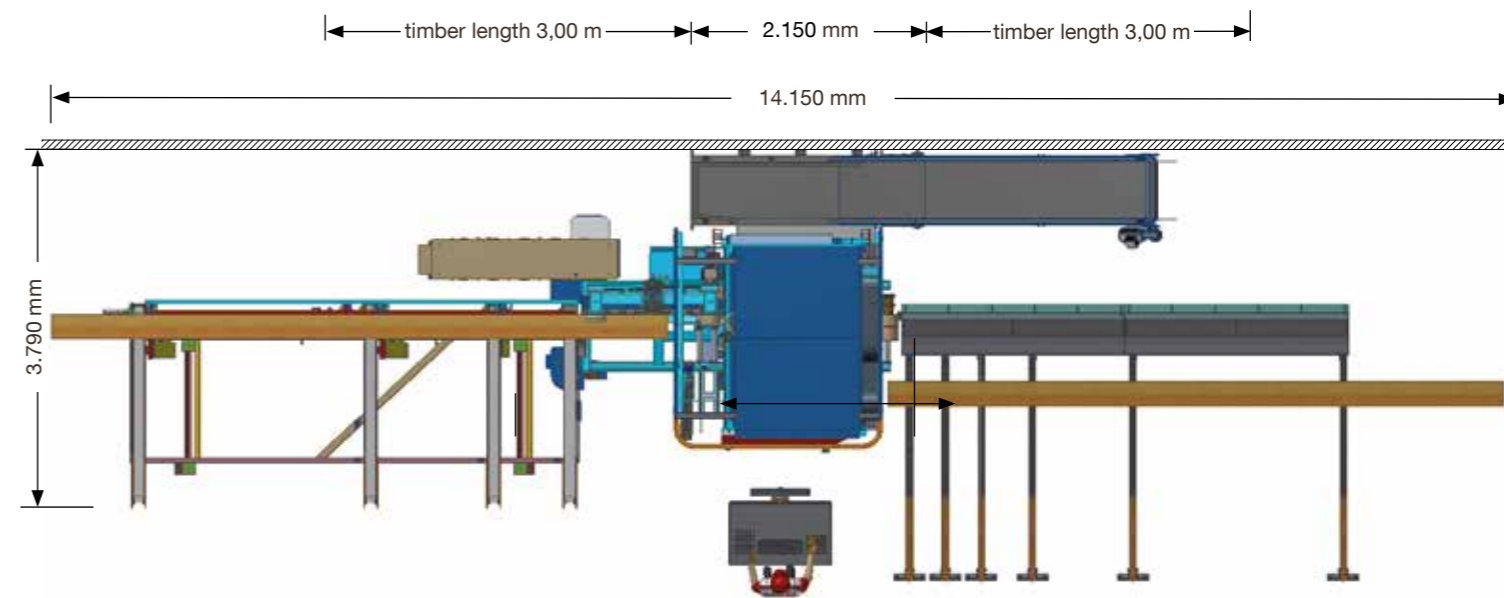
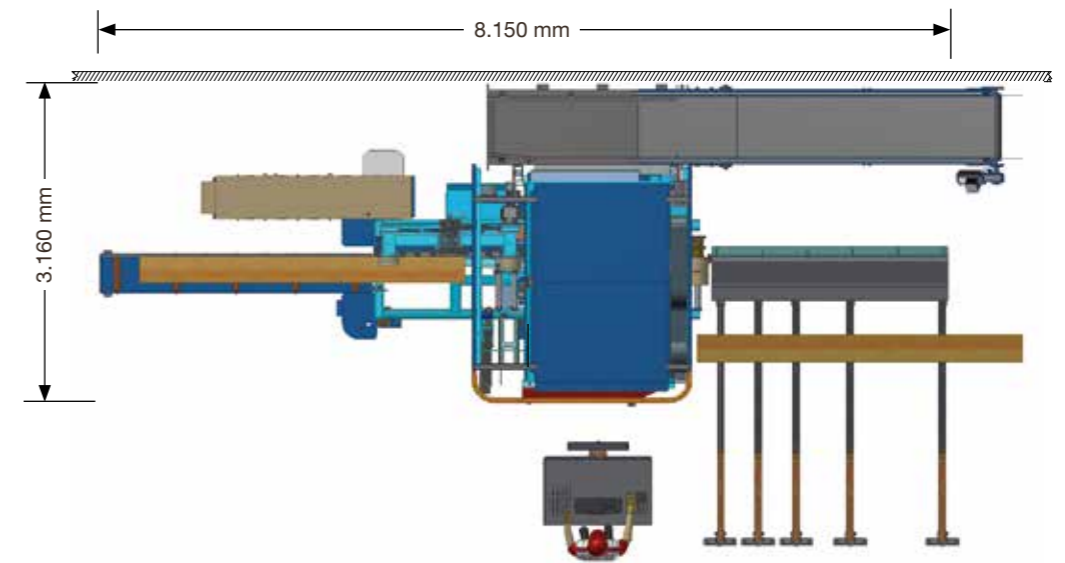

Hundegger TURBO-Drive.
Hundegger equipment has always paid for itself.
Now it just takes less time.

About the specifications in this prospectus: All specifications are subject to change. The images shown may contain accessories or special equipment which is not included in the standard scope of delivery. Images may have also been changed to not include all standard safety equipment.



Hundegger advantages

- Experience from more than 4,500 machines installed worldwide
- Custom built solutions to suit customer requirements now and in the future using the modular system
- Durable construction, industry-leading efficiency and exclusive innovations
- In-house software development team
- Continuous software solutions and free updates
- Sophisticated, yet simple, interface with all leading design software
- User friendly machine operation developed specifically for the needs of the component manufacturing industry
- Qualified training and instruction support
- 12 month warranty
- Worldwide OEM sales and service guaranteed
- Committed to Round-the-clock servicing
- Incomparable price-performance ratio



Hans Hundegger Maschinenbau GmbH
Kemptener Straße 1
D-87749 Hawangen
Telefon: +49 (0) 8332.92 33 0
Telefax: +49 (0) 8332.92 33 11
info@hundegger.de

www.hundegger.de