

# Vertical CNC Processing Centers BHX 050/055 Optimat



2015/2016

# BHX 050/055 – big can be that small...

Our CNC processing centers offer the technology of the future today. And with good reason: Tradition. For us, it is both a motivation and a commitment. Customers the world over associate the very highest standards with this. And we meet those expectations.





## BHX 050/055 – the smart allrounders for drilling, routing, grooving!

- Fast processing – **saves time**
- Takes up little room – **saves space**
- Simple operation – **saves nerves**
- Great value for money – **saves money**



### Content

- 4 BHX 050
- 6 BHX 055
- 8 All inclusive | Hardware
- 10 Standard | Software
- 11 Plausibility check
- 12 Office-Package
- 13 Length-dependent processing
- 14 power**Touch**
- 16 Technical data
- 17 **ecoPlus** advantages



**BHX 050 – the original exclusively from us...**



Fig. right:  
Example of configuration BHX 050

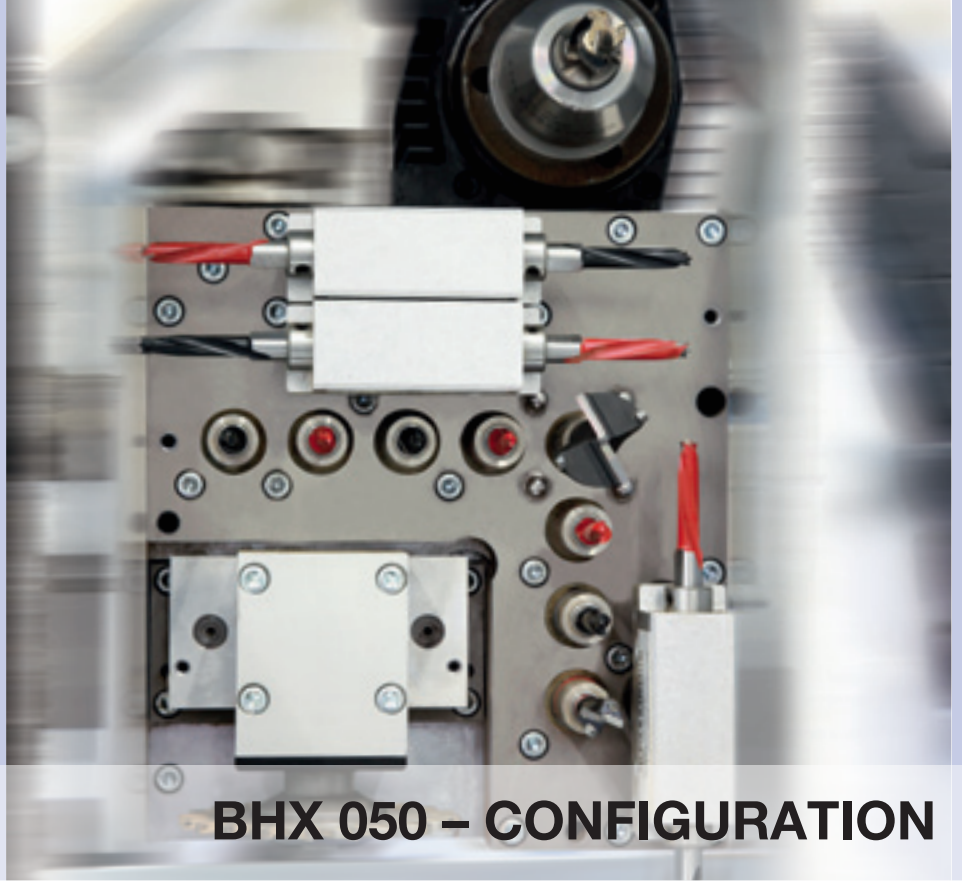

## BHX 050 – CONFIGURATION

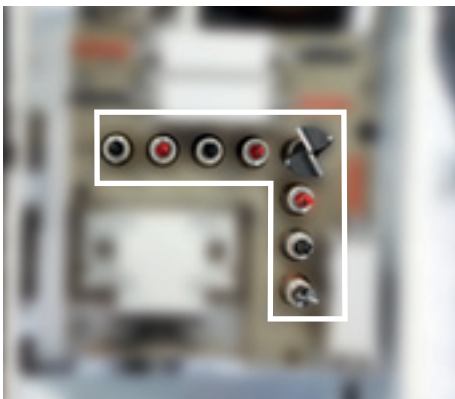

**Fig. left: Standard configuration**

- 8 vertical drilling spindles, incl. quick-change drilling system

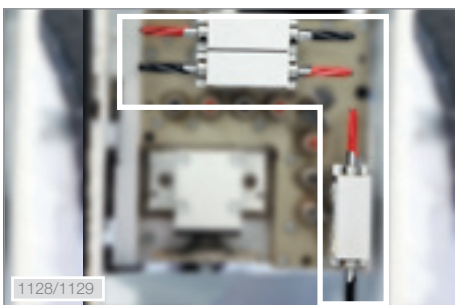

1128/1129

**Processing example**

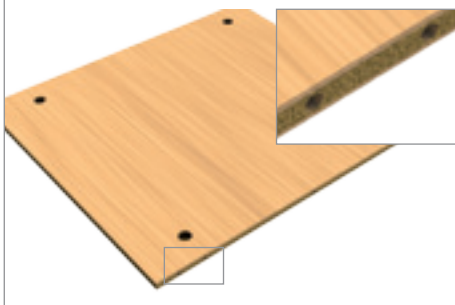

**Option – horizontal drilling**

- 4 High-speed drilling spindles in X-direction
- 2 High-speed drilling spindles in Y-direction

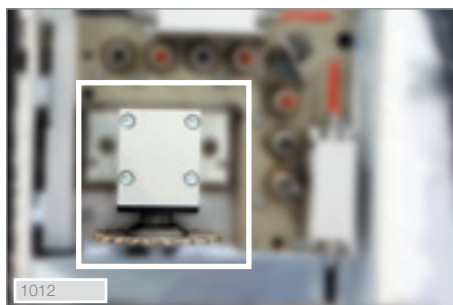

1012

**Processing example**

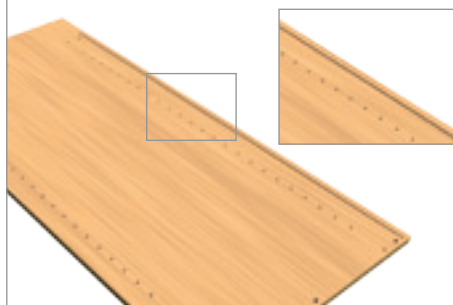

**Option – grooving**

- Grooving saw in X-direction, Ø 100 mm



1029

**Processing example**

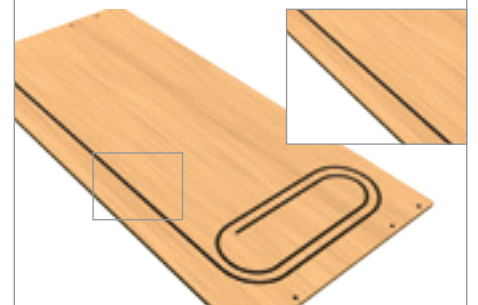

**Option – routing**

- Router motor with hydraulic quick change system, 5 kW ETP 25



**BHX 055 – more flexibility and more »drilling«...**



Fig. right:  
Example of configuration BHX 055

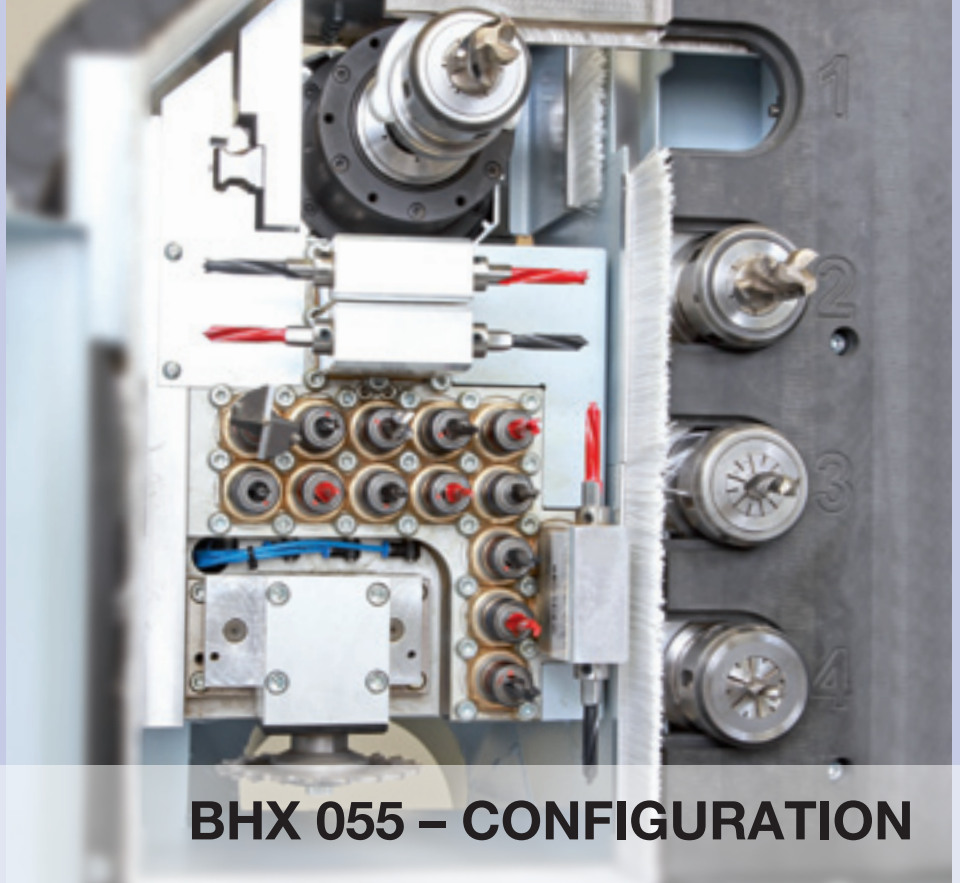

## BHX 055 – CONFIGURATION



**Fig. left: Standard configuration**

- 13 vertical High-speed drilling spindles, incl. quick change drilling system

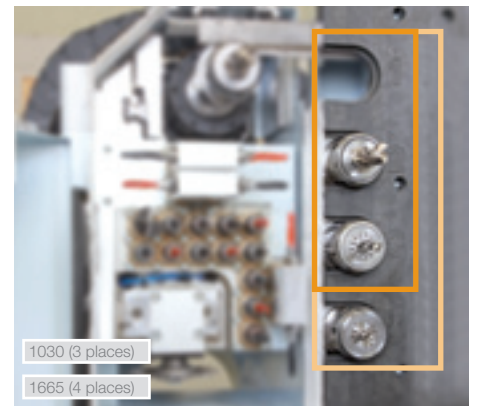
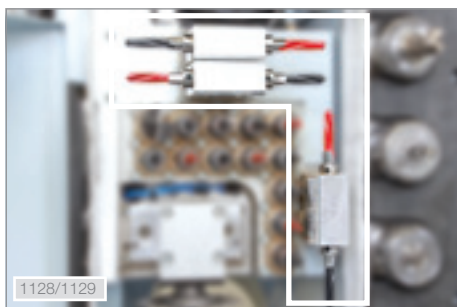

**Fig. right: Optional tool changer**

- Automatic tool change magazine with 3 places
- Extension of the tool change magazine by one place

1030 (3 places)

1665 (4 places)



1128/1129

**Processing example**

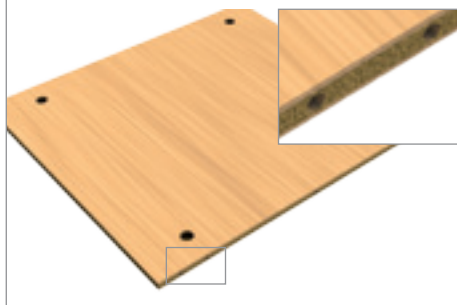

**Option – horizontal drilling**

- 4 High-speed drilling spindles in X-direction
- 2 High-speed drilling spindles in Y-direction

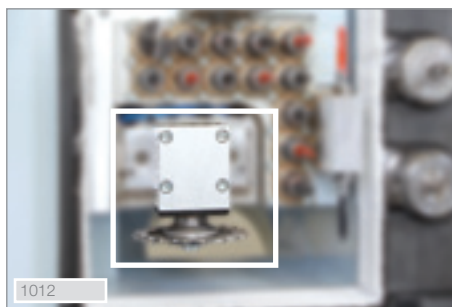

1012

**Processing example**

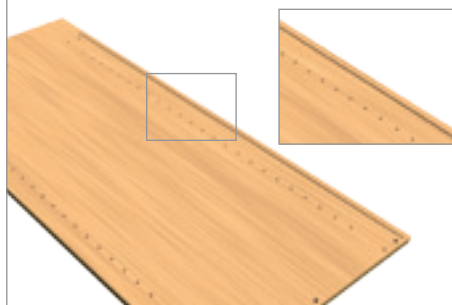

**Option – grooving**

- Grooving saw in X-Direction, Ø 100 mm

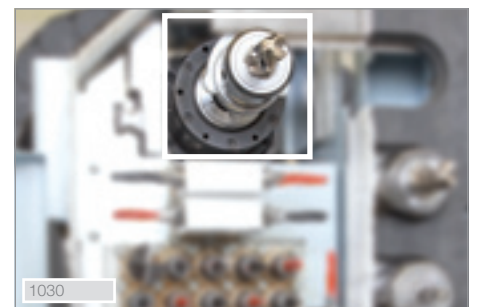

1030

**Processing example**

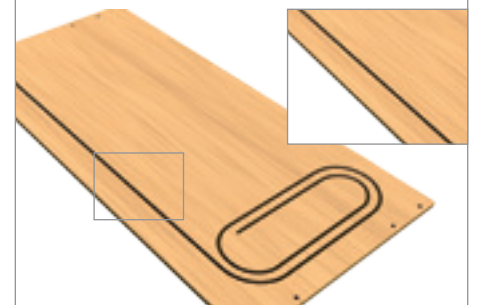

**Option – routing**

- Tool changing spindle 5 kW HSK 63

# All inclusive | Hardware

The BHX 050/055-models provide a TOP equipment right from the beginning.  
As standard the machine already comprises elementary technologies ensuring a processing quality on highest level. Sustainability pays off...



## powerControl

- 17" TFT-monitor
- Intel® inside
- Provision teleservice capability
- USB frontside bus
- Ethernet connection
- 10/100 Mbit



## High-Speed 7500

- Spindles with 1500 - 7500 RPM incl. the patented quick change system

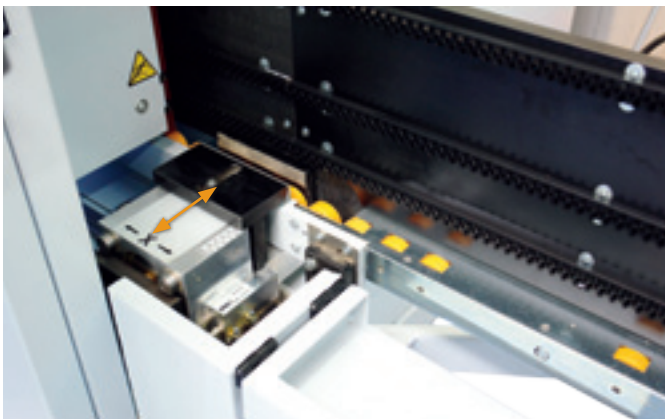

## Workpiece clamping device

- Easy adjustment of the clamping device (manually) to the workpiece thickness (clamping device stroke 10 mm). For differences in the workpiece thickness of up to 10 mm it is not necessary to manually adjust the clamping device.

Pictures may also show options





#### Automatic spindle clamping system

- Patented system for exact drilling depth at any time with different materials

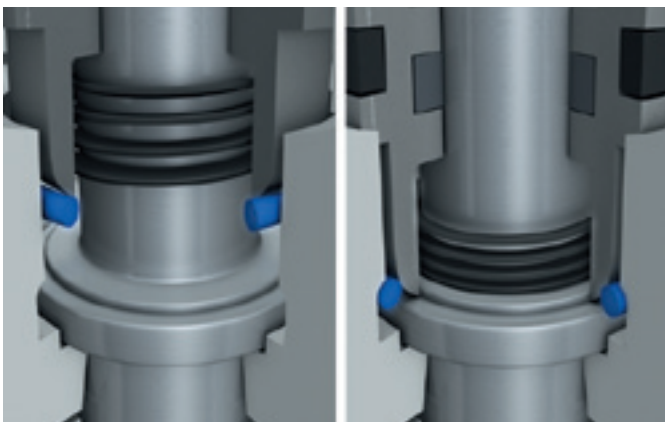

#### Workpiece load- and workpiece removal area

- Mechanical support via roller conveyor in the loading- and removal area of the machine.

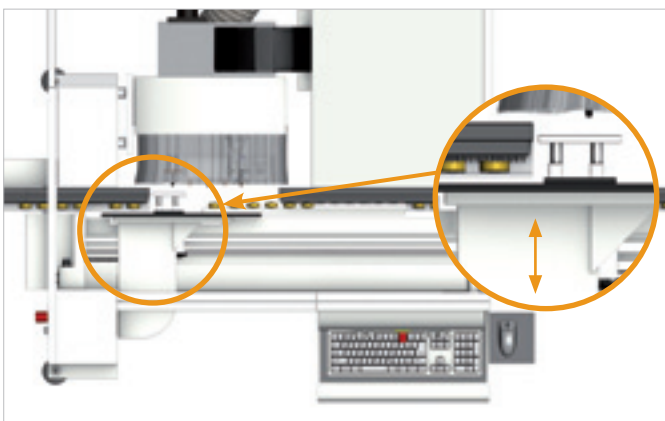
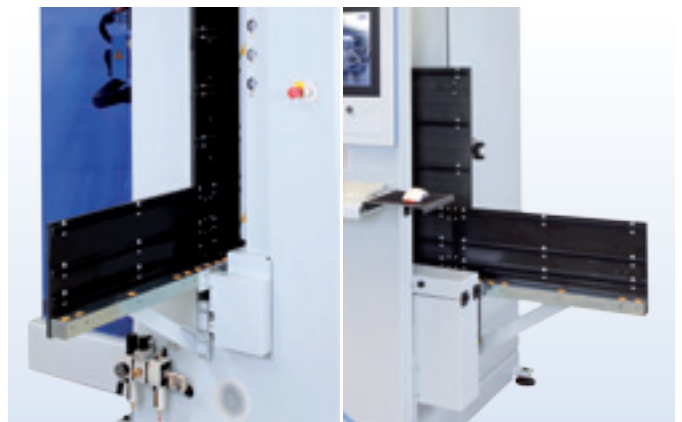

#### Automatic workpiece thickness adjustment

- Automatic adjustment of the counter block to the material thickness according to the data preselected by the operator in woodWOP



#### Working length extension from 2500 mm to 3050 mm (BHX 050: Option / BHX 055: Standard)

- Extension of the working length to 3050 mm incl. roller conveyor

# Standard | Software

With this software package you are »Ready to Race«. You will receive one of the most established CNC-programming systems, the woodWOP software, which has proven itself by more than 30.000 installations worldwide.

„THE ORIGINAL“  
SINCE 1982

## woodWOP

- Modern software based on Windows®
- More than 30.000 installations worldwide

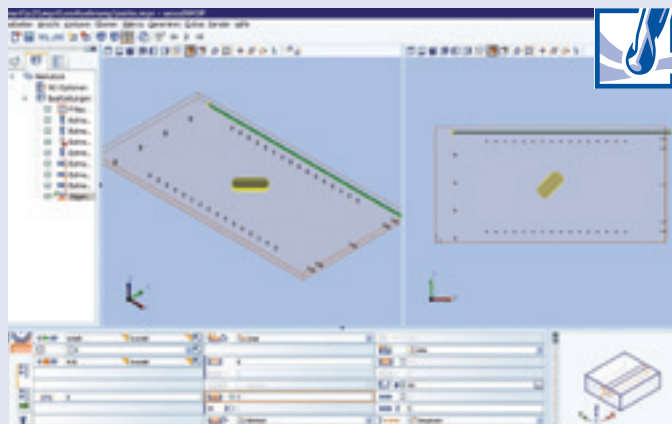

## MCC

- Simple control of main machine functions through soft keys
- Graphical loading

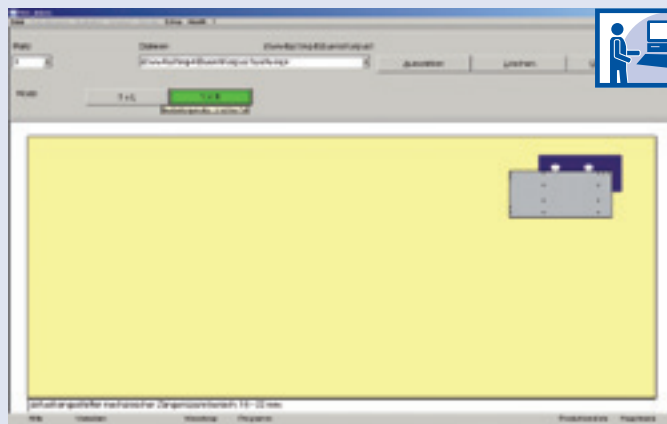

## Machine Data Recording Basic

- Machine Data Recording – collecting and evaluating machine states via time meter and event meter

# Option | Plausibility check

In order to ensure the processes even more, the BHX 050/055 models offer the option of the plausibility check. During this check the length, width and thickness of the original workpiece are checked and compared with the data indicated in the program.

If the tolerance of the values is larger than 5 mm, the operator is informed that not the correct workpiece was positioned.

## Step 1:

- Positioning the workpiece



## Step 2:

- Control of the workpiece by sensor technology in X-direction. Depending on the workpiece dimensions the shortest distance to the next sensor is selected.

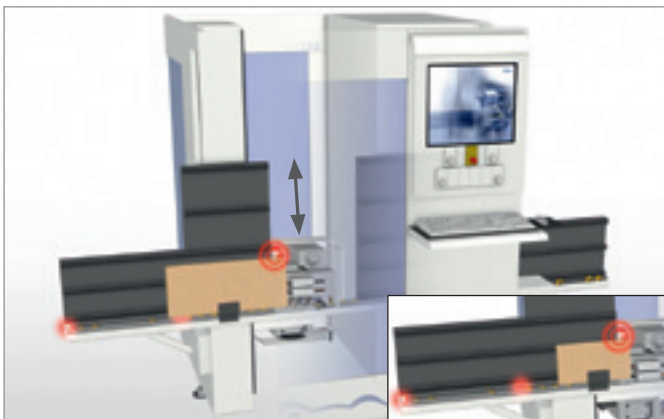

## Step 3:

- Control of the workpiece by sensor technology in Y-direction



## Step 4:

- Balancing the determined values with the program data:  
Tolerance of values < 5 mm – Program is continued.  
Tolerance of values > 5 mm – Program is stopped, advice to the operator to carry out the corrections.

# Option | Office-Package

## 3D CNC-Simulator

- Simulates the processing in the order it is stored in the NC-program
- Allows time calculation

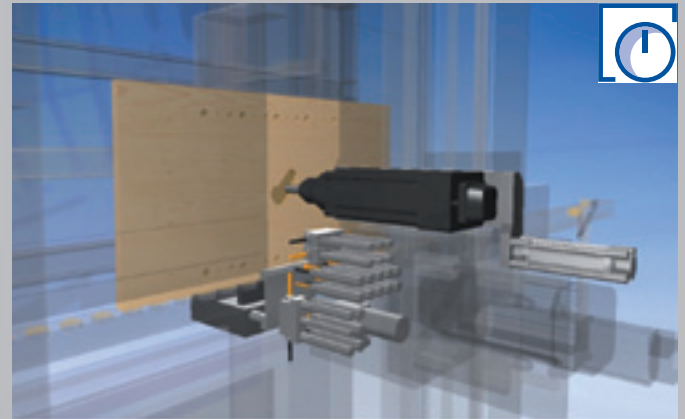

## woodWOP

- Modern software based on Windows®
- More than 30.000 installations worldwide

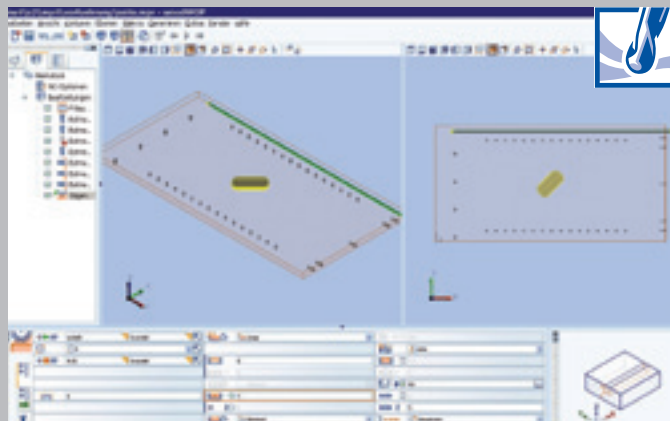

## woodWOP DXF Basic

- Interface for CAD-Data Import
- Basis to generate woodWOP programs

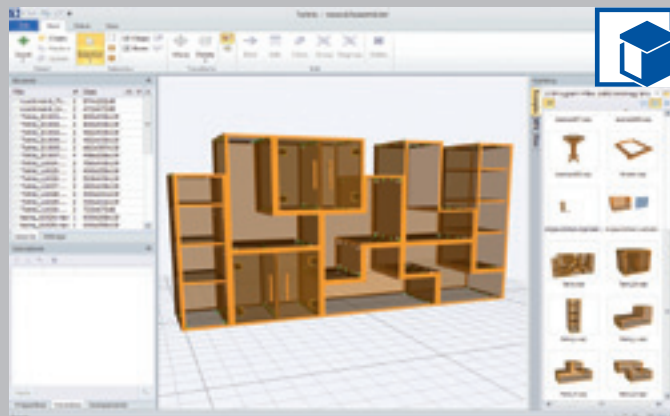

## woodAssembler

- To visualize woodWOP-programs (MPR) in 3D
- Enables the construction of individual workpieces to finished objects

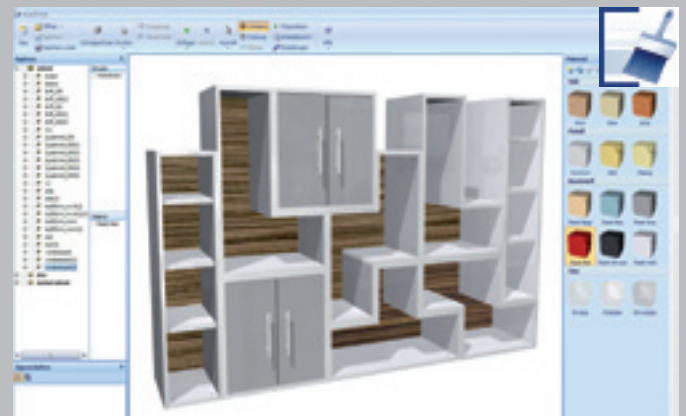

## woodVisio

- Objects generated in woodAssembler or Blum Dynalog can be provided with a surface material
- The objects are displayed in a free-standing position

# Option | Length-dependent processing in X-direction

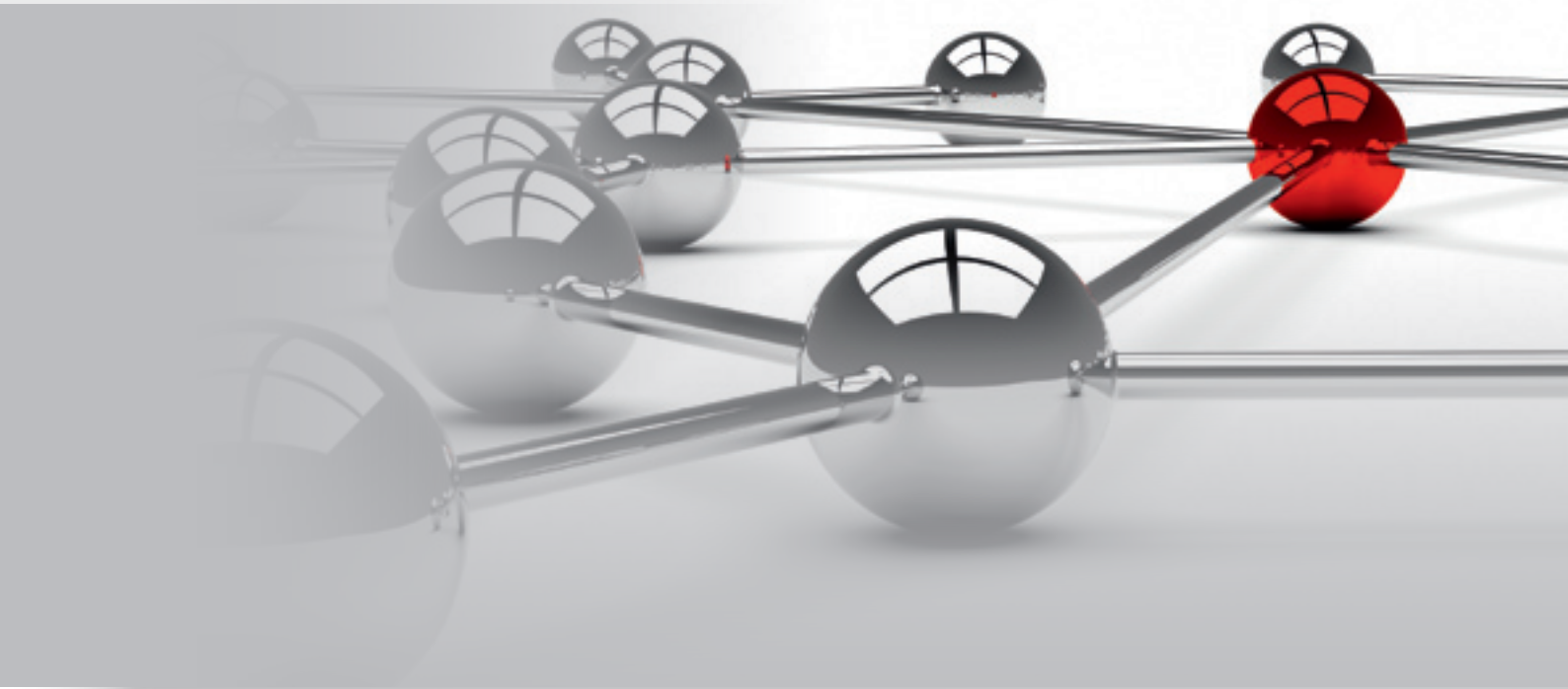

Accelerate the process – automatic adjustment of  
drillings depending on workpiece dimensions

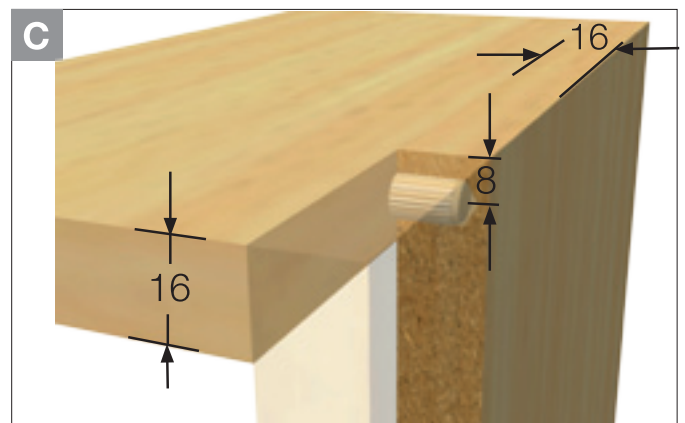

- A** After the workpiece has been released for processing at the limit stop position, a test run in X-direction is carried out (value 1).
- B** Determination of exact workpiece length (value 2).
- C** The calculation of the values 1 and 2 results in the exact workpiece length. Drills depending on dimensions are then automatically corrected by possibly determined tolerances.

# Option | powerTouch

powerTouch is the latest operating philosophy of the HOMAG Group: Simple, uniform, ergonomical, evolutionary. The new system unites design with functionality in a totally new user interface.



At the focus of this solution is a large multi-touch monitor in widescreen format, which is used to control machine functions by direct touch contact. The entire user interface has been optimized for touch operation and offers an array of help and assistance functions designed to radically simplify the work experience. Standardized control elements and software modules

ensure that all HOMAG Group machines can be operated in the same way using powerTouch. They differ only in terms of a few machine-specific details.

This not only simplifies the operation of different machines, but also makes for greater efficiency by significantly reducing time for servicing and training.

## powerControl with powerTouch

- 21,5" Full-HD multitouch display with wide screen 16:9
- USB frontside bus
- Ethernet connection 10/100 Mbit



## woodWOP

- Modern software based on Windows®
- More than 30.000 installations worldwide

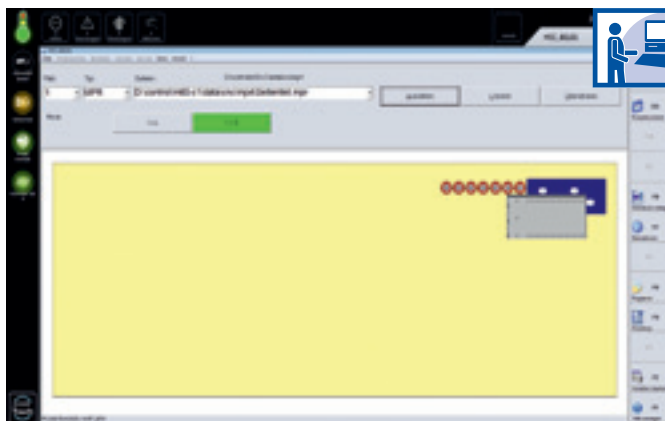
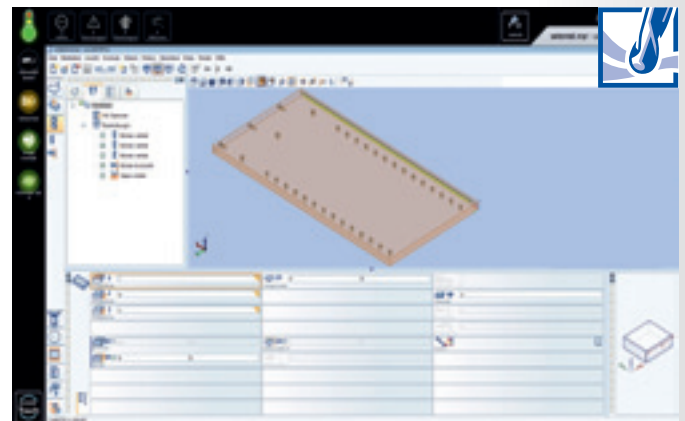

## MCC

- Simple control of main machine functions through soft keys
- Graphical loading



## Machine Data Recording Basic

- Machine Data Recording – collecting and evaluating machine states via time meter and event meter



# Always well positioned...

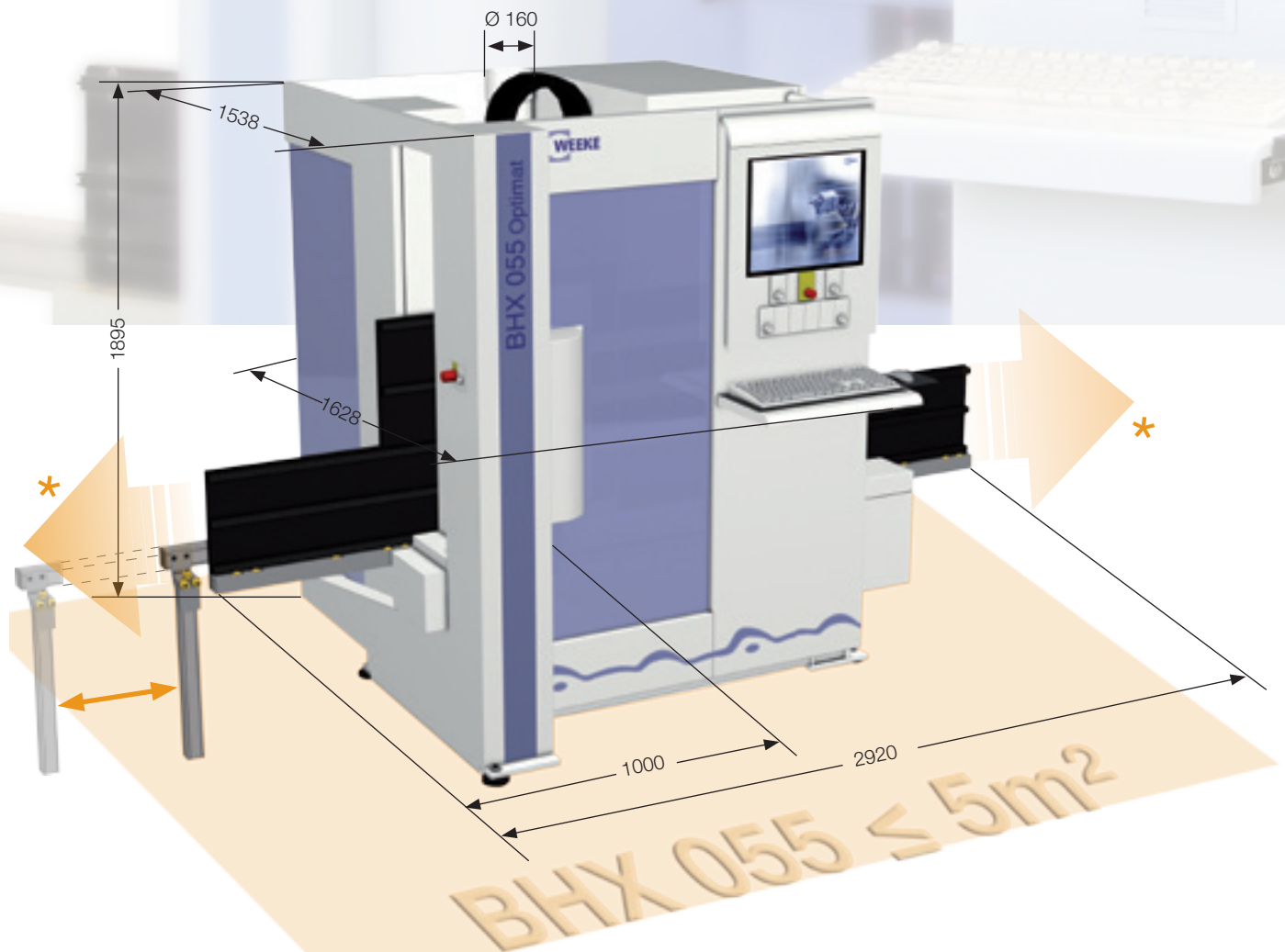

\* A corresponding safety distance must be maintained in the in- and outfeed directions! (See documentation)

Dimensions in mm

## Technical data BHX 050/055 Optimat

Workpiece dimensions **BHX 050 Optimat** L x W x T

mm

max. 2500 x 850 x 60 / option 3050  
min. 200 x 70 x 12

Workpiece dimensions **BHX 055 Optimat** L x W x T

mm

max. 3050 x 850 x 60  
min. 200 x 70 x 12

Vector speed

m/min

(X - Y) 50 - (Z) 15

Compressed air required

bar

7

Compressed air connection

inch

R 1/2

Dust extraction port

mm

Ø 160

Dust extraction volume

m<sup>3</sup>/h

min. 2170

Total machine weight

kg

approx. 1580

Electrical power – total connection load

kW

11,5





## Saving **resources** Saving **money**



ecoPlus



### **BHX 050/055 with ecoPlus**

- Low energy consumption (less than 10 kW) by efficient drive technology
- Workpiece clamping without vacuum as well as low compressed air consumption
- Efficient extraction – overall extraction output max. 2170 m<sup>3</sup>/h

### **Savings of time, material, energy and installation space ensure:**

- Potentials to apply for subsidies
- Potentials for alternative investments
- Potentials to increase your profitability
- Potentials for own marketing communication regarding environmentally conscious partnership

BHX 050/055

The magic  
always lies  
in the detail

Theodor Fontane

„THE



050/055.  
"THE ORIGINAL"  
SINCE 2009

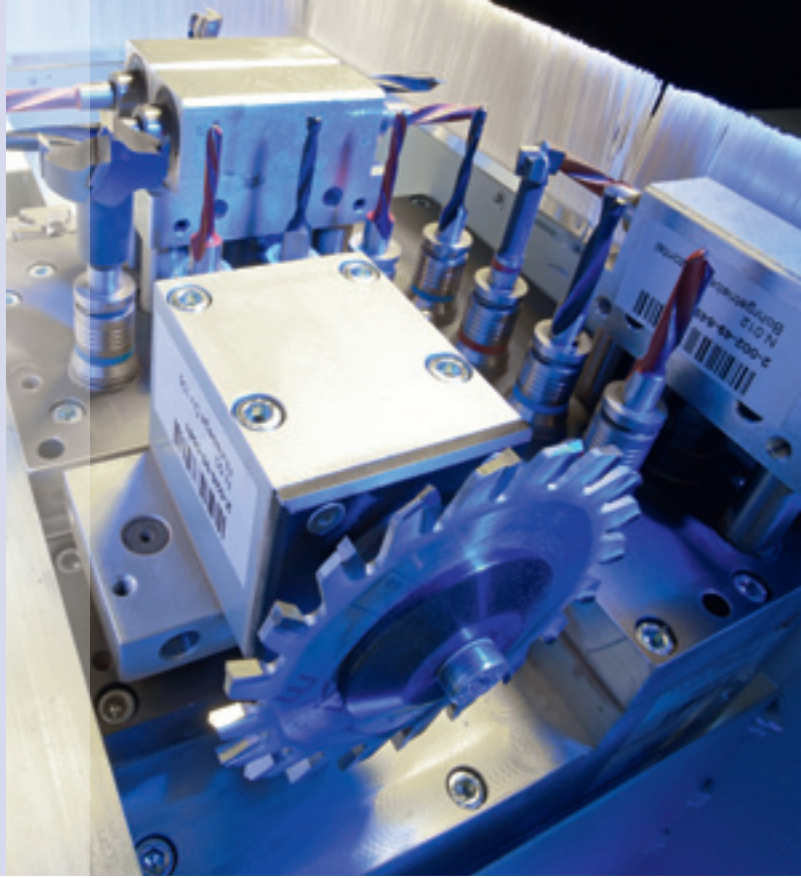

BHX 055 Optimat





**Choose the Original  
Choose Success!**

For the Success of Original Technology  
A campaign of the VDMA



**You may contact us – WORLDWIDE**

- Teleservice possibility via basic internet connection (TSN possibility)
- Competent spare parts service
- WEEKE Communication: Up-to-date information at all times:  
**www.weeke.com**
- Any questions, new ideas, criticism & praise to: **info@weeke.de**

Member of the HOMAG Group



**WEEKE Bohrsysteme GmbH**

Benzstrasse 10-16  
33442 Herzebrock-Clarholz  
GERMANY

Tel.: +49 5245 445-0  
Fax: +49 5245 445-44 139  
info@weeke.de  
www.weeke.com