

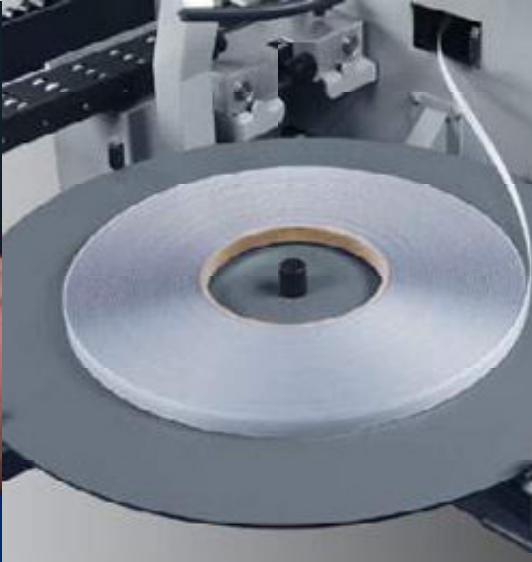

FORMAT[®]

Woodworking machines



Welcome to FORMAT-4!



The Felder Group with its company headquarters in Hall in Tirol is one of the world's leading suppliers of woodworking machines for the artisan, commercial companies and industry.

With passion, conviction and the courage to innovate, we have been following a central philosophy since 1956 and that is: to provide our customers with the exact machine that they need.

Employees in 72 countries and more than 200 retail and service centres carry this vision under the banner "Everything in one place" throughout the world. In spite of growing global demands we are committed to delivering quality and precision from our base in Austria. Our range of around 150 products is produced in the Hall in Tirol factory. Numerous international awards such as the Bavarian state award, the IF design Award and the Adolf-Loos Price, are testament to our passion and reinforce our commitment to building the best woodworking machinery on the market.



With the brands Felder, Format-4 and Hammer we succeed without compromise to fulfill the highest individual requirements of workshops, businesses and industry.

Visit our website or come and see us in our exhibition centres and experience our products for yourself. We can also develop a customised solution for you.



Hansjörg Felder



Proven

TRADITION

and consistent

INNOVATION

for perfection in

WOODWORKING



FORMAT-4 - our quality is your success!



The quality of the products is the key to our customers' success. We therefore try to work and collaborate closely with woodworkers, whether artisans, commercial companies or industry. This ongoing exchange of ideas enables us to incorporate the needs and requests of the user into the development of new machine designs and to ensure the competitiveness of our customers through optimised product design.

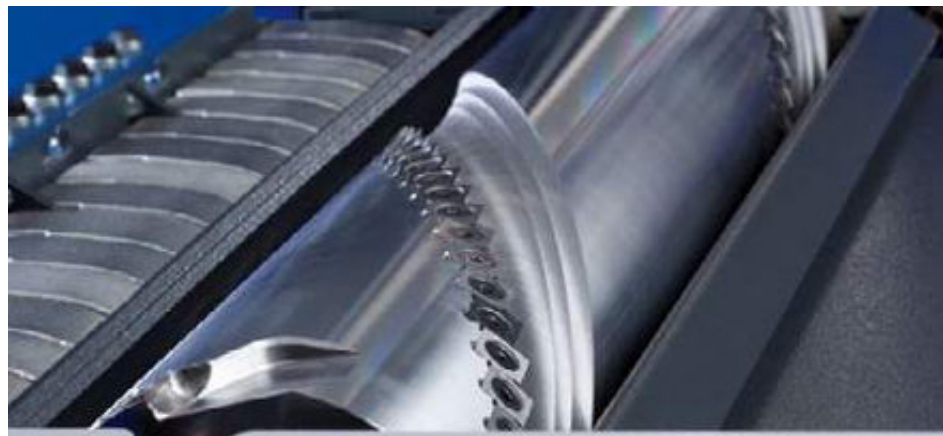

The most up-to-date manufacturing technology and strict production standards ensure excellent precision and the best processing quality. Our own research and development department, numerous international patents and groundbreaking solutions guarantee that we keep ahead of the game.



FORMAT-4 showrooms - discover a whole world of woodworking products!



With our sales and service centres, we are always close at hand.

Competent technical advisers are on hand to guide you through the full range of Format-4 products and to help you find the ideal solution to meet your individual requirements to achieve perfection in woodworking.

Visit our showrooms and test our new machines first hand experiencing the numerous innovative new developments for yourself.





The FORMAT-4 service network - always there for you!



The continuous availability of modern woodworking machines is a significant influencing factor on the productivity and profitability of a company. The Format-4 service chain ensures the operational readiness of your machines and guarantees constant precision.

With the Format-4 service network you can obtain individual all-round service to achieve perfect woodworking results right from the start. Excellent advice, competent on-the-spot help and on-site service, continual availability of machines, less down-time, optimal conservation of value and low follow-up costs - our service to you.

For more than 50 years, we have committed ourselves to developing, producing and selling first-rate woodworking machines. Today, Felder-Group machines are amongst the best selling in the world.



Specially trained service personnel are at your disposal to provide specialised on-site service for you all over the country. If the matter is urgent you can call our hotline centre for straightforward immediate help.

FORMAT-4 customers - driven by conviction and passion!

Every day woodworkers all over the world decide on a woodworking machine from Felder. With this decision they become not just a customer but a consultant on perfect woodworking.



"My kappa 550 is the best. For about 18 months now my kappa 550 has been nothing but perfection. Time required to format and rip timber has been cut by more than half."

Master Carpenters Siegfried & Martin Heubacher, Austria



"All promises were kept, the user interface is simple and self-explanatory."

Lux Innenausbau, Interior fitters, Germany



"From the first meeting through to the installation of the machine and the first processes and even with the correct choice of tools, we were looked after by competent Format-4 expert advisers and technicians. The advantage of the machine and the software coming from the same supplier, is that no excuses can be given: For optimum productivity CNC and software must work together smoothly!"

Schreinerei Epp, Carpenters, Germany



FORMAT-4, the right decision!



Individual solutions for individual requirements

Each and every Format-4 woodworking machine is custom built to your requirements. We will strive to meet your every need when putting together your machine. Your exact current and future requirements are considered in detail before manufacture to ensure you make no compromise on the specification of your machine.

You can rely on our woodworking machines

Meticulous design and production, innovative development and high quality standards without compromise are the trademarks of a Format-4 machine. Important criteria such as stability, durability and functionality are standard characteristics of our machines!

Quality from Austria

Format-4 woodworking machines are top quality Austrian products. 100 % of the design and construction is carried out at the factory in Hall in Tirol. Cutting edge processing techniques and machinery as well as constant quality controls guarantee the quality, precision and reliability of your woodworking machine.



Advice that you can rely on

Tailored support at Format-4 begins long before the purchase decision has been reached. After a detailed requirements analysis an individual solution is put together for the customer using our technology centre and showrooms. By simulating the customer's manufacturing operation, it is possible to test different machine concepts ensuring that the perfect solution is found, meeting the individual requirements of the customer and ensuring perfect woodworking.

Always working for you: The FORMAT-4 Service team

Specially trained technicians carry out the delivery, installation, commissioning and the first machine configuration settings. This ensures that your machine can be used productively from the very first day of use.

In the next link of the Format-4 service chain our customers profit from a tailored inspection and maintenance package as well as a competent service hotline for immediate support. Numerous Format-4 service centres ensure the availability of a Format-4 service technician as well as a problem free spare part supply. Customers with a computer controlled machine have the possibility to enrol their employees in a comprehensive software and machine training program.



Panel Saws

Planers

Thicknessers

Planer-Thicknessers

Format-4 woodworking machines have been tested by leading European institutions and are supplied with the safety equipment and means of protection required in the country of destination. The illustrations may sometimes show special equipment and accessories not included in standard machinery. We are not liable for any changes in technical data subsequent of going to print. For standard equipment and prices please see the latest price list.

Tilting Spindle Moulder



08 kappa 550



10 kappa 550 x-motion
Touch screen control



12 kappa 550 e-motion
Touch screen control



36 kappa 400



38 kappa 400 x-motion
Touch screen control



58 plan 51



68 plan 51L



78 exact 51



79 exact 63



90 dual 51



104 profil 45 Z



profil 45 Z x-motion
Touch screen control



106 profil 45 M



profil 45 M x-motion
Touch screen control



CNC Machining Centres

Edgebanders

Wide Belt Sanders

Industry panel saws

Format-4 woodworking machines have been tested by leading European institutions and are supplied with the safety equipment and means of protection required in the country of destination. The illustrations may sometimes show special equipment and accessories not included in standard machinery. We are not liable for any changes in technical data subsequent of going to print. For standard equipment and prices please see the latest price list.

Heated Veneer Press



134 c-express 920



138 profit H20/H22/H22 L



154 profit H50/H50 L
5 axes spindle



166 profit H08



172 profit H10



186 perfect 608
x-motion plus



perfect 710
x-motion/e-motion



perfect 812
x-motion/e-motion



206 finish 1102/1302



212 kappa V60



214 kappa automatic 55/75
3200 x 3200/4300 x 4300



220 HVP Typ 1/2/3/4

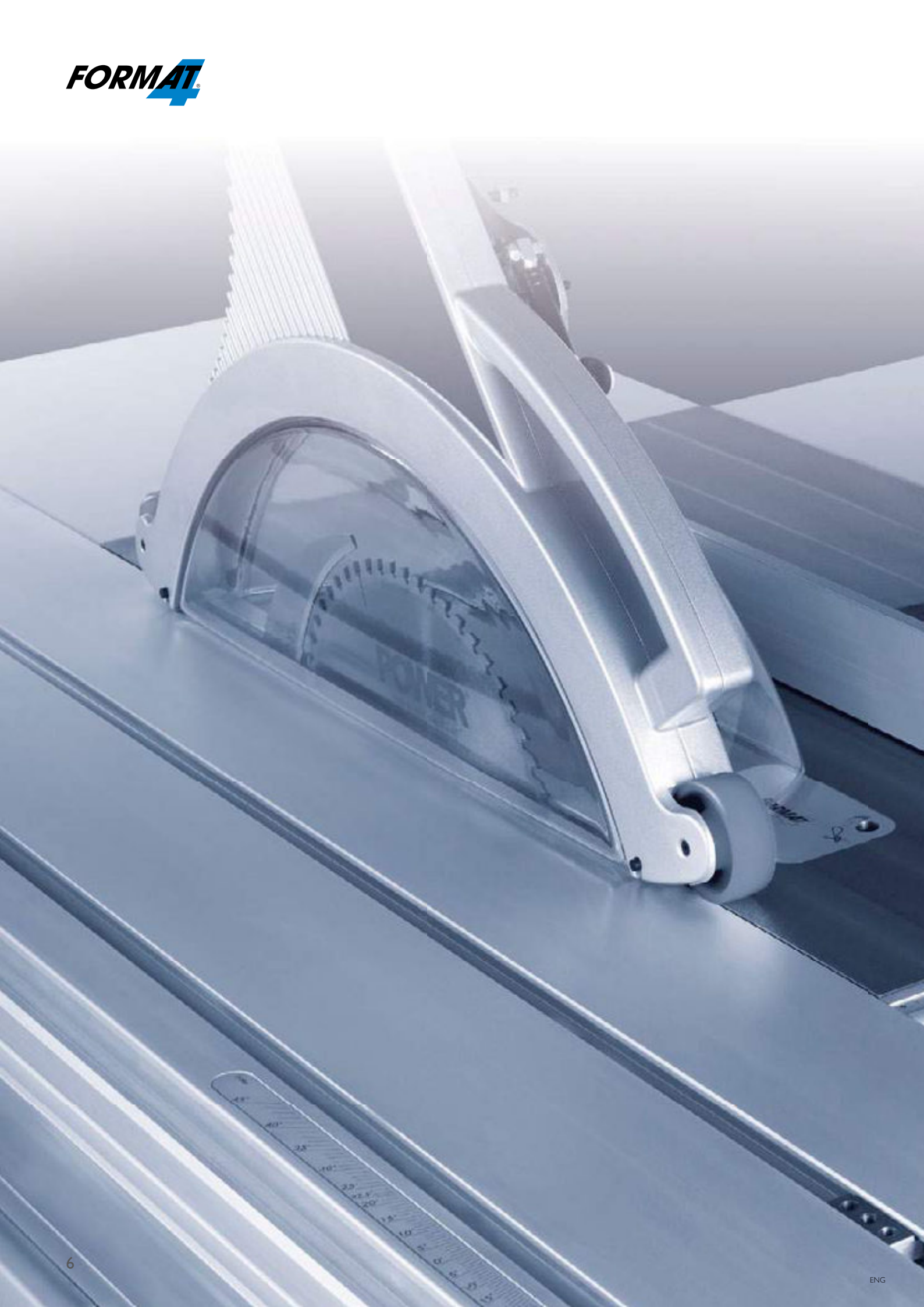

kappa 550

The first choice when it comes
to panel saws





kappa 550

Setting the standard for size, performance and precision

The Format-4 kappa 550 is the absolute premium machine for professional woodworkers. Award winning design, numerous impressive detailed solutions and a first class operating concept ensures maximum efficiency and a noticeable increase in the productivity of every workshop.



CNC control with LED display

- 202 mm cutting height
- Aluminium sliding table with "X-Roll" precision guiding system
- Cutting length 2800–3700 mm
- Tooling compartment with space for 5 saw blades (option)
- Electronic height adjustment with LED display
- Electronic angle adjustment with digital LED display (0°–46°)

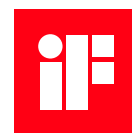

design award
winner



The machine illustrations may show optional equipment. Please refer to your individual quote for clarification on which options are included.



kappa 550 x-motion

Professional sliding table saw with up to 6 controllable axes, modern technology and maximum user comfort

As part of the x-motion package the CNC positioning of the aggregate is carried out using the 5.7" colour touch screen. With the integrated tooling database and the 9x 99 program positions the kappa 550 x-motion guarantees maximum efficiency and repeatability.



3 axes CNC control with 5.7" (145 mm) colour touch screen in the overhead control panel

- 202 mm cutting height
- Aluminium sliding table with "X-Roll" precision guiding system
- Cutting length 2800–3700 mm
- Tooling compartment with space for 5 saw blades (option)
- Colour control panel with touchscreen
- Electronic height adjustment with LED display; position controlled
- Electronic angle adjustment with digital LED display (0°–46°); position controlled

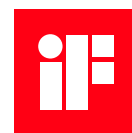

design award
winner



The machine illustrations may show optional equipment. Please refer to your individual quote for clarification on which options are included.



kappa 550 e-motion

The top model for maximum performance and productivity with up to 7 controllable axes

The first choice when it comes to panel saws: The particular highlights that impress with the kappa 550 e-motion are the automatic rip fence, unlimited tooling data storage positions and programable cutting programs. From the clearly laid out TFT touch screen control unit you can set all of the machine elements from a central position.



CNC control with 10.4" (264 mm)
TFT screen situated in the overhead-control panel

- 202 mm cutting height
- Aluminium sliding table with "X-Roll" precision guiding system
- Cutting length 2800–3700 mm
- Tooling compartment with space for 5 saw blades (option)
- Colour TFT control panel with touchscreen
- Electronic height adjustment with LED display; position controlled
- Electronic angle adjustment with digital LED display (0°–46°); position controlled
- Unlimited number of cut program storage positions
- Unlimited tool storage positions

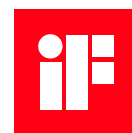

design award
winner



The machine illustrations may show optional equipment. Please refer to your individual quote for clarification on which options are included.

The most important highlights at a glance

30

Electronic crosscut fence (option)

16/17

Cutting height 133 mm,
Scoring unit with park position and 2 controllable axes

6 Year Guarantee on "Easy-Glide" Format-4 tilting segment

31

Swing away overhead saw guard

The choice is yours:
Outrigger table with mitre index system,
"X-Roll" - or parallelogram outrigger table

28/29



22

Up to 7 positionable axes
(e-motion)

25

Position controlled rip fence

Rip capacity 1000 – 1600 mm

26/27

“X-Roll” sliding table guiding system
with 10 year warranty

Tooling compartment with
space for 5 saw blades (option)

33

Remote ON switch on
sliding table (option)

27

Circular saw unit 200

SENSATIONAL: Scoring unit park position

- The scoring blade no longer needs to be removed!
- The scoring blade can be parked at the push of a button
- Saw blades with a diameter of up to 550 mm can be inserted without having to remove the scoring unit

NEW: 3-axis "Control" scoring unit – Save and retrieve scoring positions

- Electronic control for setting the saw blade height, angle and the rip capacity
- Storable and retrievable scoring positions
- Saw blade diameter not limited as scoring blade can be moved into the park position

Large cutting depth, even with a scoring unit

- 202 mm of cutting depth at 90 degrees,
140 mm at 45 degrees
(saw blade diameter 550 mm)
- 125 mm cutting depth with the scoring
unit (saw blade diameter 400 mm)
- Saw blades with a dia. of up to 400 mm
can be lowered under the table

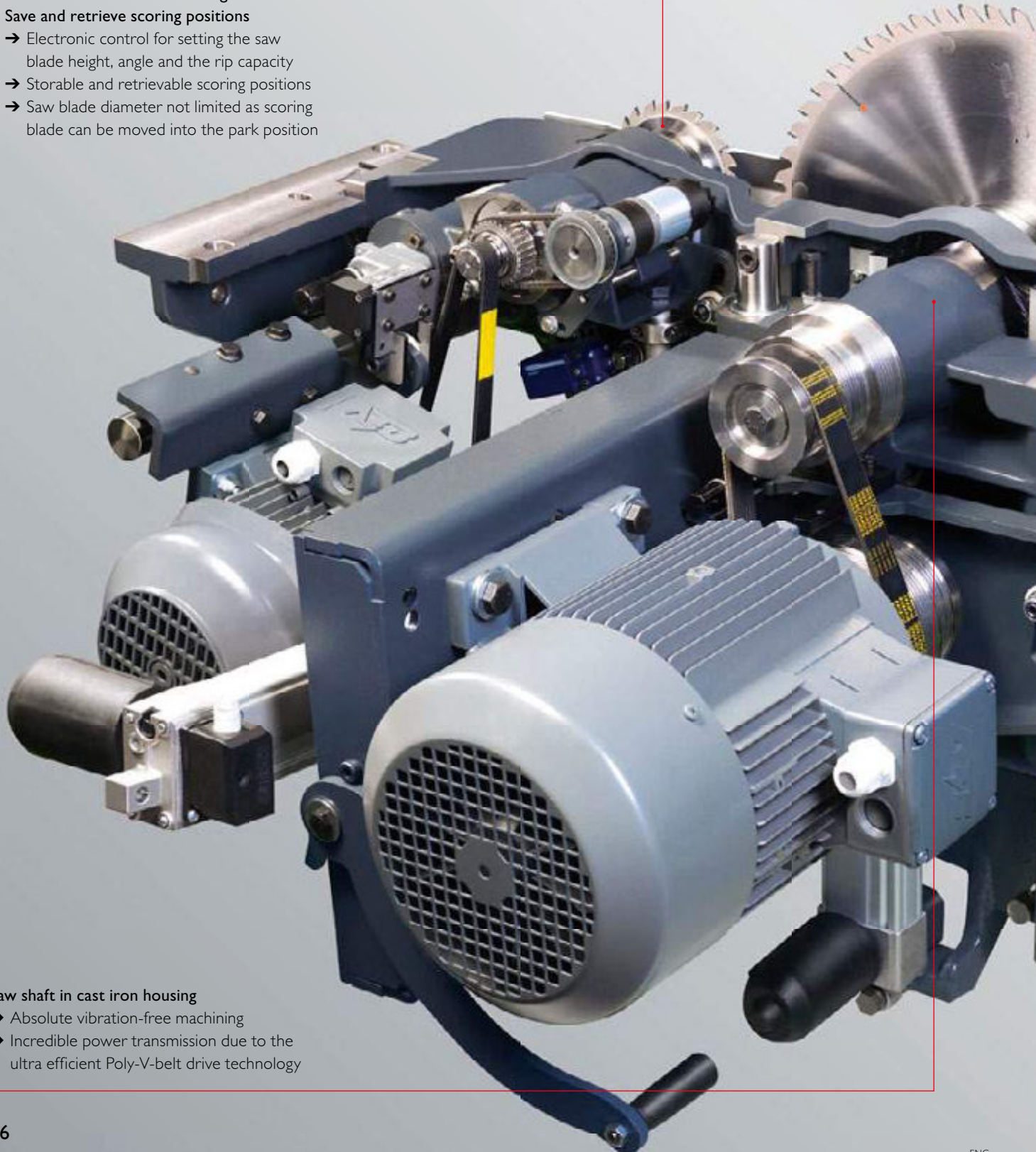

Saw shaft in cast iron housing

- Absolute vibration-free machining
- Incredible power transmission due to the ultra efficient Poly-V-belt drive technology

Produce grooves with your panel saw

- Removable flange (Standard)
- Clamping unit for slotting cutters (601-130)
- Dado tooling with a grooving width of up to 19.5 mm can be inserted

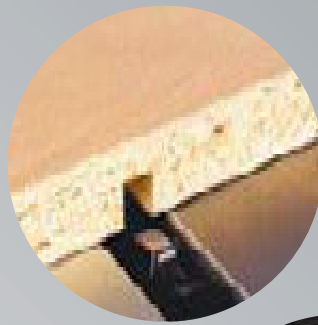

Spraying equipment (option)

- To help process light alloys and plastics

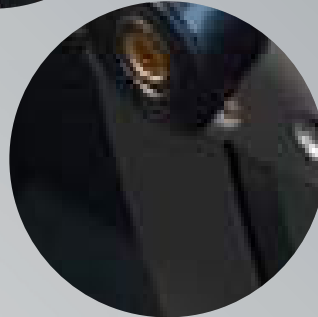

Zero point tilt for precise mitred cuts

- Zero point tilt from 0–46 degrees
- 202 mm of cutting height at 90 degrees, 140 mm of cutting height at 45 degrees

You will not find better than the “Easy-Glide” tilt segment!

- High precision double-sided trunnion support system
- High load-bearing capacity and operating life
- Play-free tilt
- Unaffected by dust
- Completely maintenance free
- No lubrication required
- 6-year guarantee

Precision height adjustment:

Robust, precise and durable

- Hardened precision linear guides
- Maintenance-free recirculating ball bushings
- High load-bearing capacity and operating life
- Unaffected by dust
- Completely maintenance free
- No lubrication required



Dust extraction below the table for great extraction results

- Extremely well designed dust extraction pipe for optimum results

6

YEAR GUARANTEE
on “Easy-Glide”
Format-4
tilting segment

Scoring unit



Scoring unit “Control”

The scoring unit blade width and height adapt automatically to the stored tool information and also to the respective teeth width of the main saw blade. Any changes to these standard scoring settings can be saved and retrieved when using the same tool in the future. The 3-axis scoring unit “Control” is available as an option with the x-motion and e-motion models.

“Classic” scoring unit

The height and lateral scoring blade settings can be manually adjusted on the side of the saw table. Optionally you can upgrade the “Classic” scoring unit to the electrically controlled height positioning option “Automatic”.

“Automatic” height adjustment

The height adjustment of the scoring blade can be carried out electrically with the turn of a knob, the lateral positioning is manual. When switching the scoring unit on, the scoring blade moves automatically upwards into the preset position and then drops below the table again when switched off, now that is top class comfort!

Scoring unit with 2 controlled axes

The scoring unit blade height and lateral position relating to the saw blade can be positioned with ease using the control panel. The scoring blade data can be saved in the database specific to a certain saw blade. Next time the saw blade is used, the scoring blades moves automatically into position.

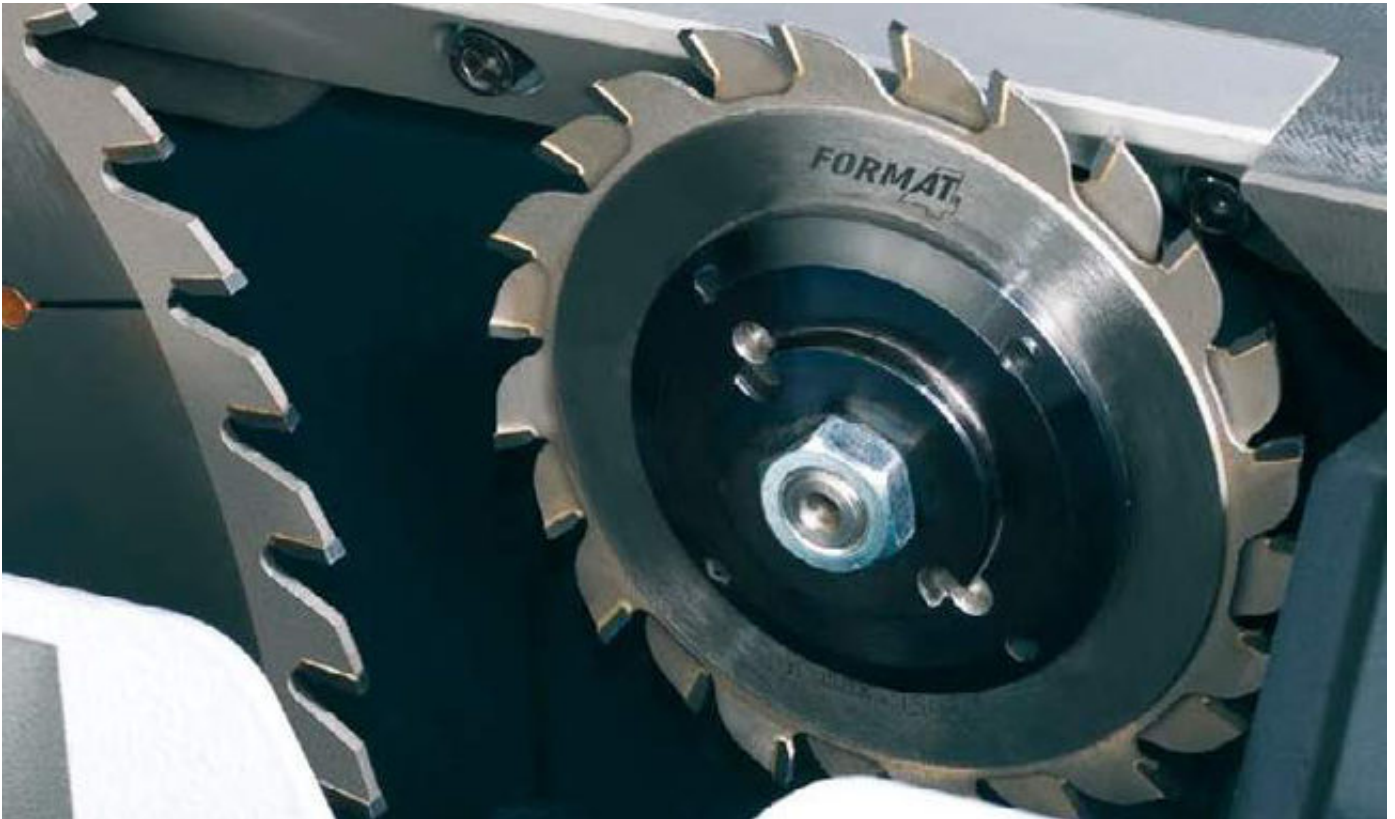

The scoring unit no longer needs to be removed!

Removing the scoring blade when using large diameter saw blades is no longer necessary! The new Format-4 parks the scoring blade at the touch of a button, leaving enough space for a large diameter blade, and in doing so, saves valuable production time. Additionally the park position also protects the scoring blade from resin.

Change the saw blade without using any tools



Fast, uncomplicated and totally without tools: Changing the saw blade on the new Format-4 machine is incredibly simple. The patented power transfer system ensures that the required pressure on the flange is applied. A clamping lever is used for the tool free clamping of the riving knife. Maximum operating safety and maximum productivity are guaranteed with Format-4.



kappa 550 x-motion, up to 6 positionable axes



CNC control with 5.7" (145 mm) colour touch screen

in the overhead control panel

- Positioning control of the saw blade height
- Positioning control of the saw blade angle
- Automatic cutting depth compensation when tilted
- Saw speed display
- Control for variable saw blade speed (Option)
- Positioning control of the rip fence with automatic measurement correction when the saw blade is at an angle (Option)
- All possible functions also available in touch control mode
- 99 storage locations in the tool database
- 9x 99 storage locations for cutting programs
- + "Control" 3-axis scoring unit (Option)
- + Control system for 2 axes scoring unit (Option)
- + Program with stored functions (grooves, row of grooves, rabbets, wrong mitre, mitred cuts, calculator)

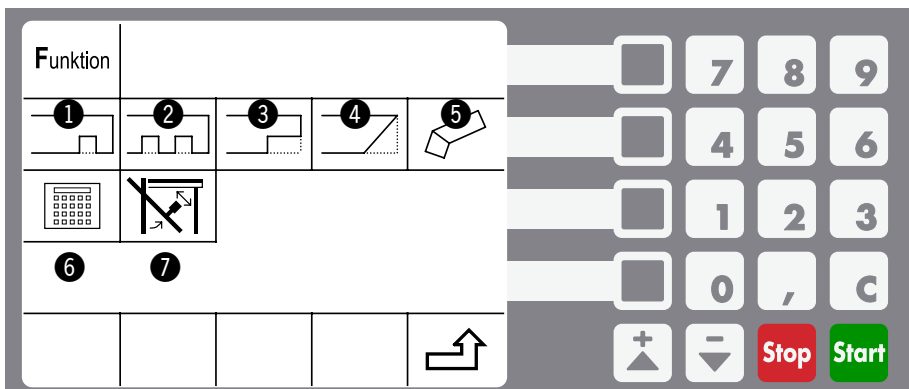

Special functions, x-motion Standard

These special functions are always recalculated for the tool currently being used and converted into a program (cutting sequence).

- ① Grooves
- ② Notches
- ③ Rabbets
- ④ Diagonal cuts
- ⑤ Wrong Mitre
- ⑥ Calculator
- ⑦ Compensation of length for mitred cuts

kappa 550 e-motion, up to 7 positionable axes

CNC control with 10.4" (264 mm)

TFT touch screen in the overhead control panel

- Positioning control of the saw blade height
 - Positioning control of the saw blade angle
 - Automatic cutting depth compensation when tilted
 - Saw speed display
 - Control for variable saw blade speed (Option)
 - Positioning control of the rip fence with automatic measurement correction when the saw blade is at an angle
 - All possible functions also available in touch control mode
 - Unlimited tool storage positions
 - Unlimited number of cut program storage locations
- + "Control" 3-axis scoring unit (Option)
 - + Program with stored functions (grooves, row of grooves, rabbets, wrong mitre, mitred cuts, calculator)
 - + Possibility of free program designation
 - + USB-Port
 - + Network connection setup
 - + Ardis Cutting Optimisation Software (Option)
 - + Barcode scanner, label printer (Option)



Ardis Cutting Optimisation Software

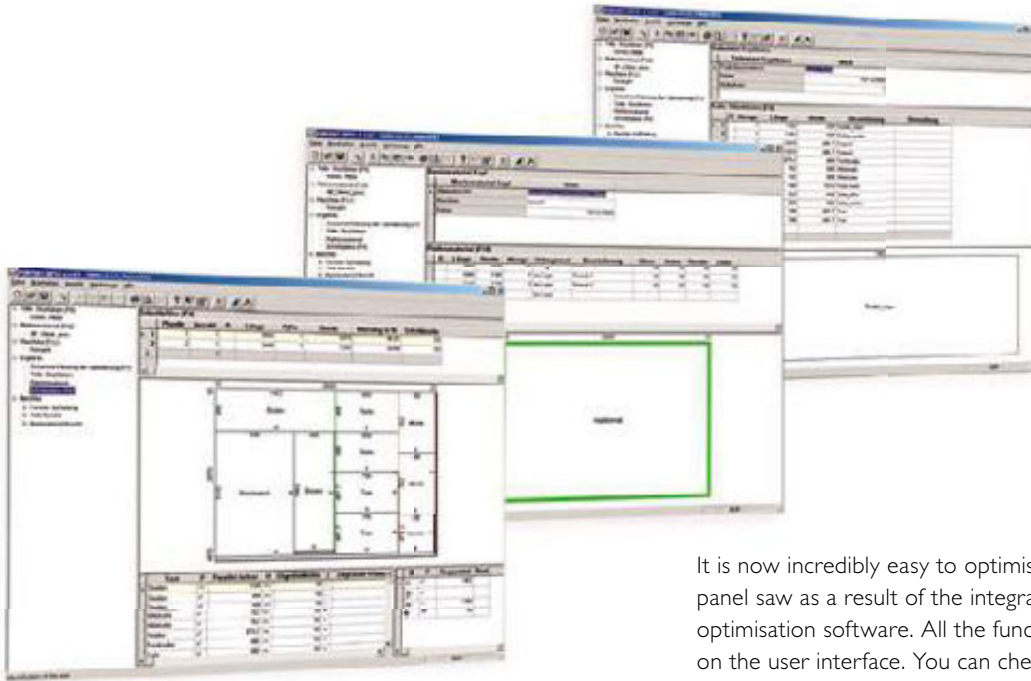

It is now incredibly easy to optimise cuts with the Format-4 panel saw as a result of the integrated Ardis cutting optimisation software. All the functions are clearly displayed on the user interface. You can check the tool width and the formatting cut quickly and easily as well as the cutting direction entered in the cutting list and the direction of the grain of the veneer.

The advantages are clear

All processing phases can be carried out quickly, efficiently and centrally as a result of the integration of the Format-4 cutting optimisation system into the machine and operating concept. Training is not necessary as the user interface is intuitive, clear and easy to use.



Label printer

Not only does the label printer enable the workpieces to be labelled correctly, it also enables a rational post-processing. CNC and edgebander programs can also be saved and then imported using the barcode reader. Save valuable production time with the label printer and increase productivity, quality and as a result, your profit.



Rip fence



Great standard equipment

The highly visible scale on the saw table enables accurate settings and the rip fence has a tilt and inversion function.

- Table scale as standard
- Fine adjustment as standard



Option

Rip fence of the highest quality

The single handed adjustment system ensures quick and accurate setting of the rip fence. Fine adjustment is also included as standard. In the standard version the rip capacity is 1000 mm, but it is available as 1250 or 1600 mm as an option. The easy to read rip scale is perfectly integrated into the saw table. The aluminium rip fence plate can be swung away to help load larger workpieces.

Electronic digital display can be read from every position.

The integration of the optional electronic digital display on the rip fence allows for the reading of the cutting width to one tenth of a millimetre. The display can be rotated up to 90° to suit the working position. Additional features, such as fine progressive adjustments in increments of 0.1 mm make precision cutting a reality.

Electronic digital display (option)

- Brightly illuminated red LED display facilitates the reading of values
- No batteries are required as it is directly connected to the machine's power supply
- Recognises automatically whether the fence is in the vertical or horizontal position
- Measurement compensation of the saw blade tooth width



When working with narrow and thin cuts of wood with the saw blade at an angle, the rip fence can be placed face down to improve operator comfort and avoid collision with the saw blade. The rip fence can also swung away underneath the table surface.

Positioning control of the rip fence

The rip fence is positioned by a motor and runs via a dust-free integrated ball spindle in the saw table. Accurate to 0.1 mm, high travelling speed and simultaneous positioning of the rip fence, saw blade cutting height and saw blade angle ensure precision and save valuable working hours.

- Automatic measurement correction when the rip fence is laid flat
- Rip fence park position
- No collision possible with the saw blade due to the coordination of the tool database by the positioning control
- The rip fence can be swung away at any point along the full rip capacity





Sliding table “X-Roll”, 10-year guarantee

A masterpiece of engineering -
The ultimate in precision and smoothness.

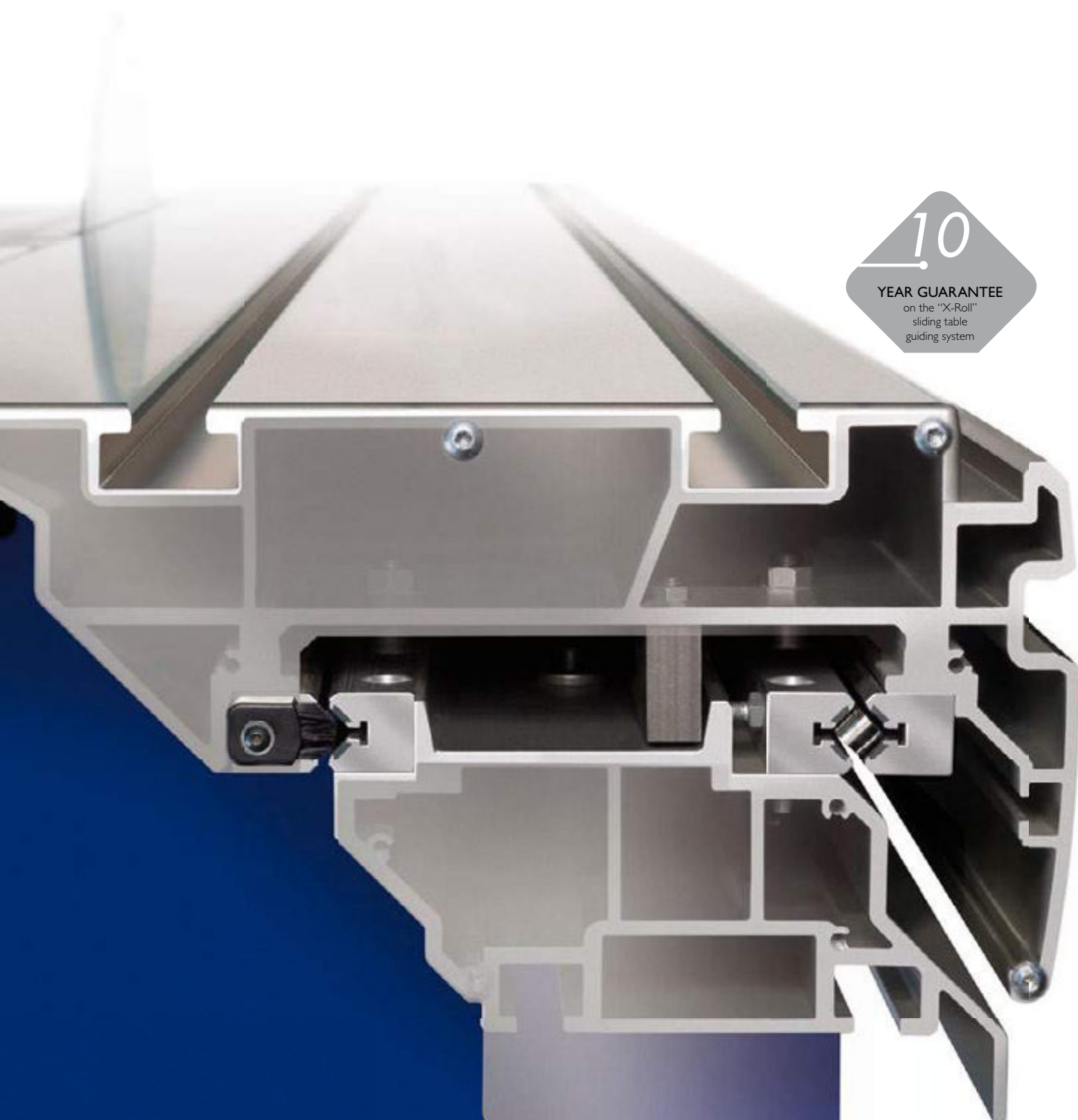

10
YEAR GUARANTEE
on the “X-Roll”
sliding table
guiding system

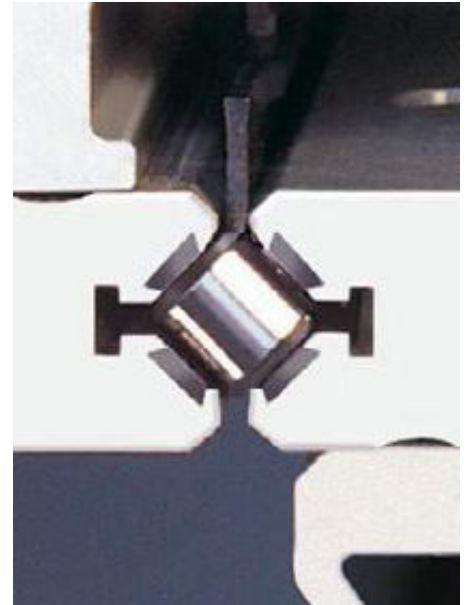
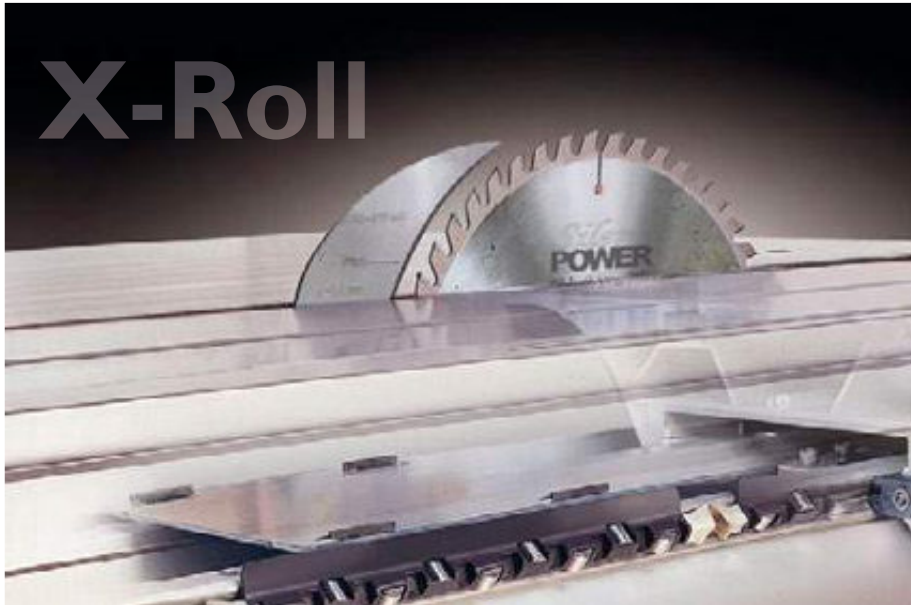

This precision guiding system takes maximum loads without compromising the smooth and accurate stroke of the sliding table. The "X"-configuration of the roller bearings optimally distributes workpiece weight to all sides. With a roller bearing system, the full width of the bearing is in contact with the guiding track. With no single point of contact between the bearing and the guiding track as found on conventional ball bearing systems, the roller bearing will never wear a groove into the guiding track. This ensures play-free guiding for the lifetime of the machine. The "X-Roll" system is backed with a 10-year factory guarantee.



Protected from dust
Dust protection due to the special "12 fold" wiper system.
→ 4 wiping brushes
→ 8 silicon wipers

Durable
Long lasting tracks with the Format-4 linear guiding system. No single point of pressure.

Maintenance-free
Maintenance-free and dust protected due to covered guiding tracks positioned sideways on the inside.

Stable
Extremely warp resistant due to the solid profile construction.

"X-Roll", making a difference:

- Extremely smooth running and durable guiding system. The use of roller bearings ensures that there is no single point of contact between the bearings and the guide track!
- The dust resistant construction of the 3-way dust protection system ensures dust free and clean guide tracks.
- Hardened and ground bearing tracks.
- 10 Year guarantee on the "X-Roll" sliding table guiding system.



As an option, it is also possible to equip the saw with the wireless push button control "ON" switch of the main blade and scoring blade to the sliding table, speeding up the work process further.

Outrigger tables, the choice is yours ...

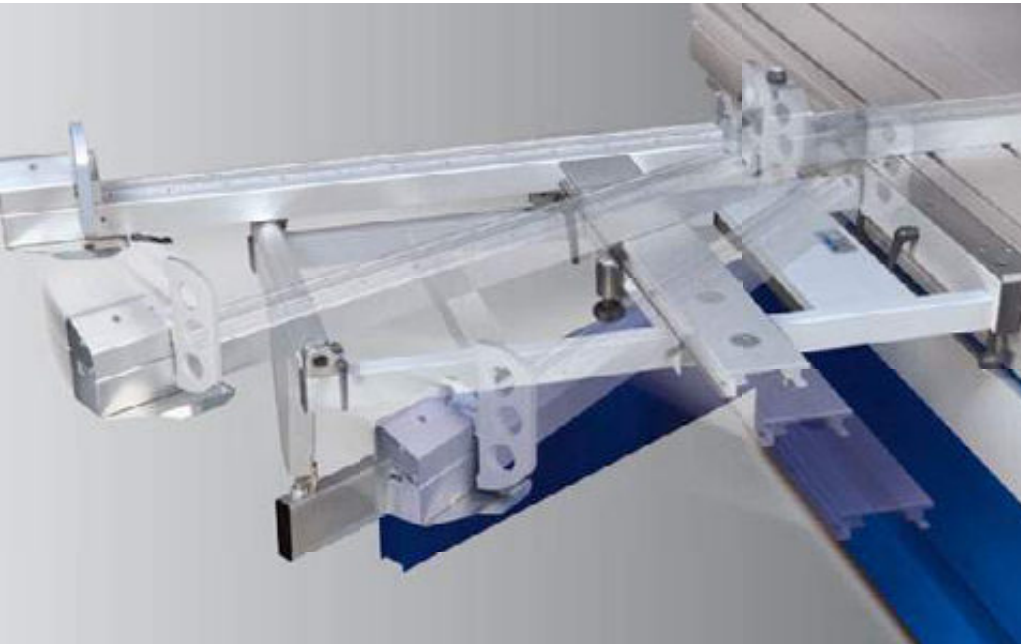

“X-Roll” outrigger table

The support rail is moved along an “X-Roll” guiding system and is fast and fine-adjustable. The LED display enables you to set the required angle to one tenth of a degree. The telescopic crosscut fence can be positioned at the front as well as the back of the outrigger. The angle/length compensation is carried out using either a Nonius scale or “digi-compensation”. The “X-Roll” outrigger table combines the advantages of the standard outrigger and the parallelogram outrigger at an incredibly attractive price:

- Accurate 90° stop
- Easy setting of the mitre angle
- Large supporting surface
- Welded framework ensures increased stability

NEW: “digi-compensation” - Digital angle/length compensation

On both the “X-Roll” and Parallelogramm outrigger tables the exact position of the crosscut stop is calculated using the angle setting which is transferred to the stop via radio signal.





Precision mitre guide index system outrigger table

Time consuming angle approximations as well as reading and calculation errors are a thing of the past. Adjust and lock in place without losing time - the highly precise pin index enables the accurate manufacturing of multiple sided pieces with ease.

Additional indexes at intervals of 5 degrees from 15° to 45° are available by sliding out and back into the one required. Each index point is equipped with a length compensation that can be fine adjusted if required.

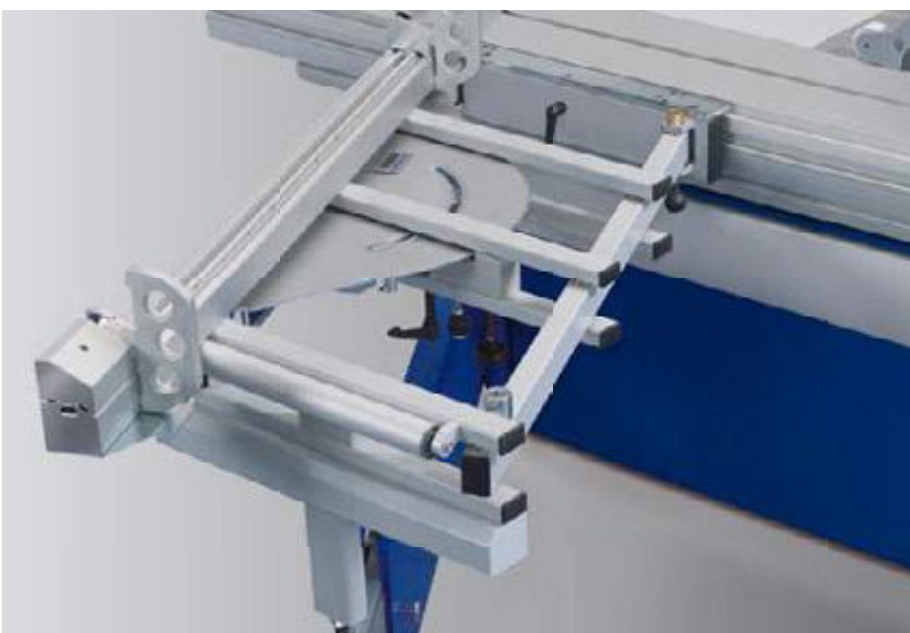

Parallelogram outrigger table

The solidly built parallelogram outrigger table enables mitre cuts from -45° to +45°.

The surface available for the workpiece remains the same regardless of the angle setting. The digital display of the angle setting is accurate to 1/100th of a degree. The angle/length compensation is carried out using either a Nonius scale or "digi-compensation".



Digital accuracy

As an option, we can equip your Format-4 with the digital telescopic fence, this includes an integrated electronic digital scale with values accurate to 0.1 mm. Additional functions, for example the setting of incremental measurements, make your daily working life easier.



Telescopic crosscut fence

The telescopic fence enables crosscuts of up to 3200 mm. Top class engineering and ease of use are features which are a part of the standard equipment. The scale and the magnifying glass on the stop ensure precise adjustments and settings from the operating area.



Parking the outrigger

The outrigger no longer requires dismantling is very easy to operate and has a small space requirement. The outrigger table can be swung out of the way with ease! No more time consuming, complicated assembling and removing of the outrigger table. The outrigger table swing away system on the new kappa 550 ensures extreme ease of use and at the same time can provide you with extra working space when you need it.

Available as an option for:

- Standard outrigger table
- Precision mitre guide index system outrigger table
- "X-Roll" outrigger table
- Parallelogram outrigger table



Electronic crosscut fence

The e-motion models can be equipped with the CNC controlled crosscut fence. The controlled crosscut fence can be used on both sides of the outrigger and is equipped with two fence stops. The maximum adjustable length measures 3400 mm. The extendable component can be removed to save space. The length compensation takes place automatically depending on the set angle.

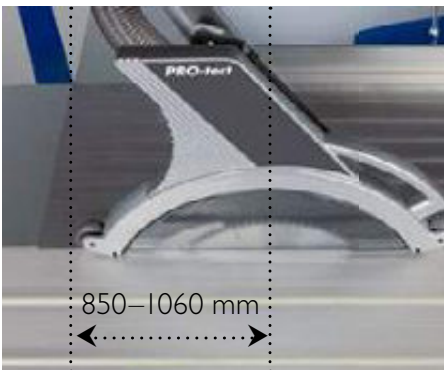
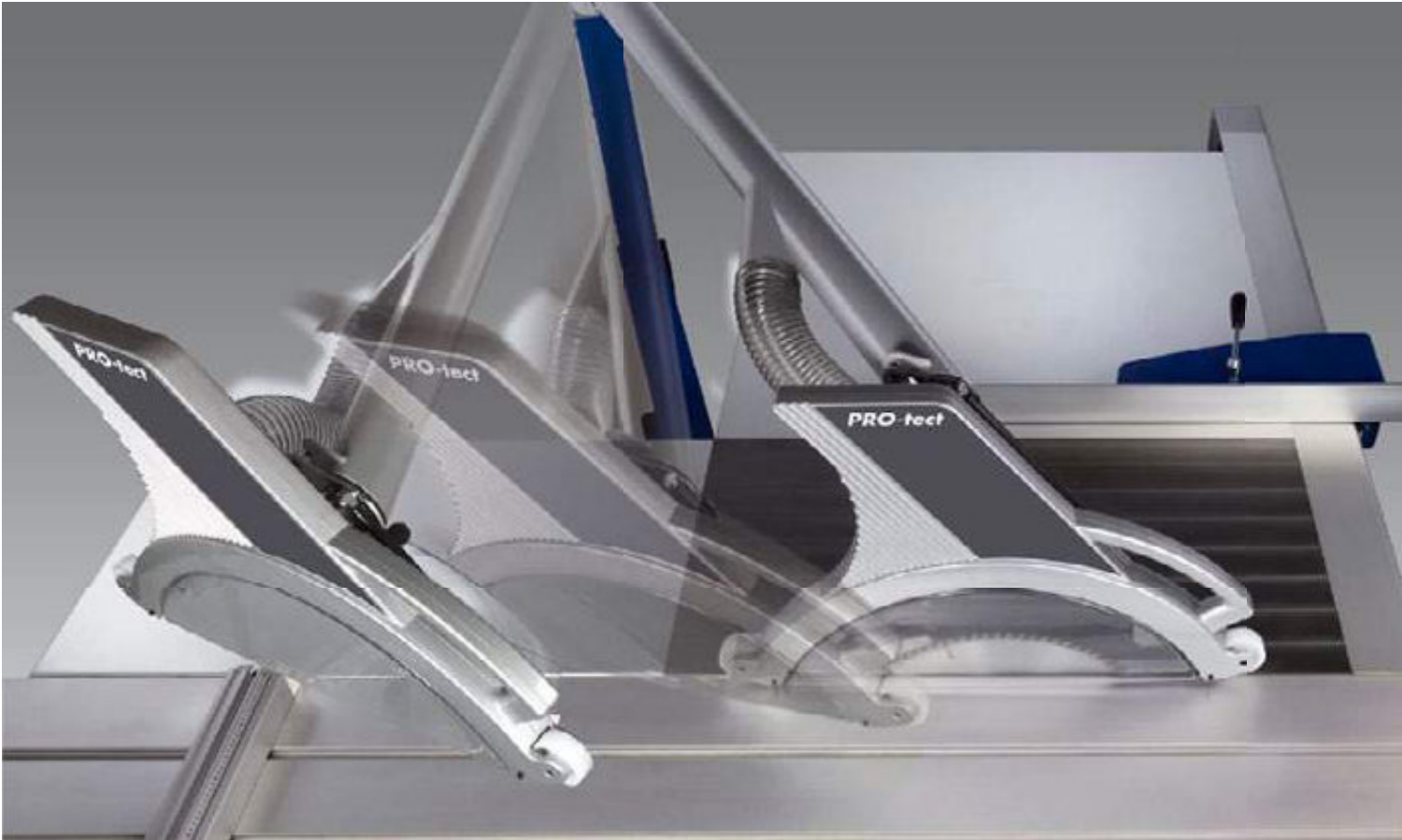

Overhead saw guard

The Format-4 overhead saw guard is integrated stylishly into the machine design. It is easy and convenient to use. The saw guard can be moved and tilted completely away from the machine area with just a flick of the wrist. The dust extraction hood adjusts itself automatically to the workpiece height and always provides optimal working safety and dust extraction performance.

Free cutting from the centre of the saw blade to the overhead saw guard support is 850 mm at the maximum cutting height. Depending on the cutting height and saw blade diameter, a free cut of up to 1060 mm can be achieved. Therefore long panels, e. g. kitchen worktops, can be cut with ease.

The newly developed overhead saw guard and dust removal system deliver perfect extraction results. The overhead saw guard, with its striking design, runs on linear guides that help to facilitate the height adjustment. The dust and shavings are sucked from the saw guard into the extraction pipe via a short hose.



Remote lock release

As an option, the kappa 550 can be equipped with a remote lock release. This enables you to easily tilt the overhead saw guard away from the front of the machine.



Clamping systems

Pneumatic pressure bar

Both halves of the pressure segments can be controlled individually.
Clamping length of 3000 mm and height of 80 mm.

→ Particularly suitable for long and thin materials such as veneer

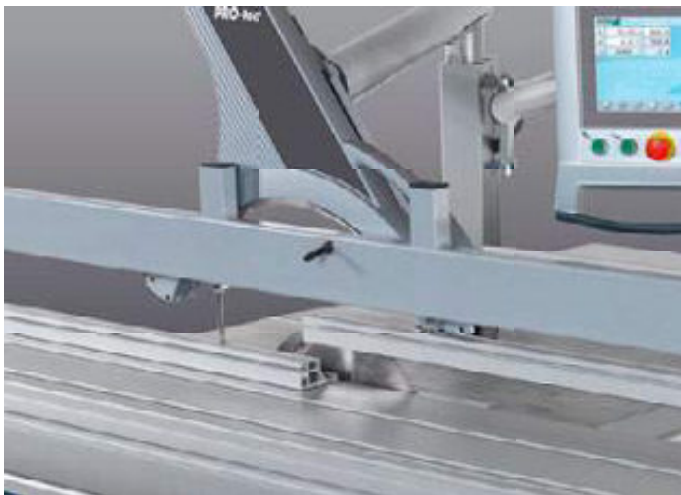

Pneumatic workpiece holder

Easy clamping of workpieces with maximum flexibility,
can be used on all panel saws and spindle moulders
that have a sliding table.

Advantages:

- Easy set up due to magnetic fitting
- Safety cylinder ensures maximum work safety
- Pressure bar function possible with every sliding table length
- Locking height: 95 mm, clamping force: approx. 300 kg

Options that impress!



Tool compartment

- Integrated tooling storage in the machine chassis
- Storage room for 5 saw blades, max. dia. 400 mm

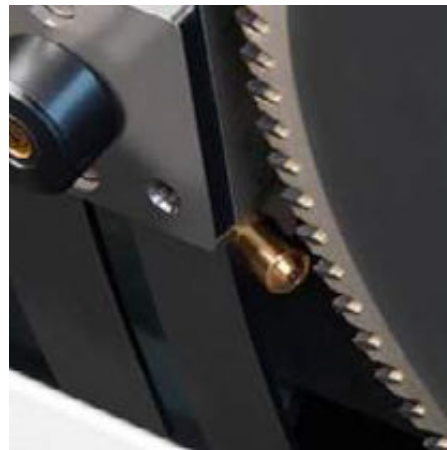
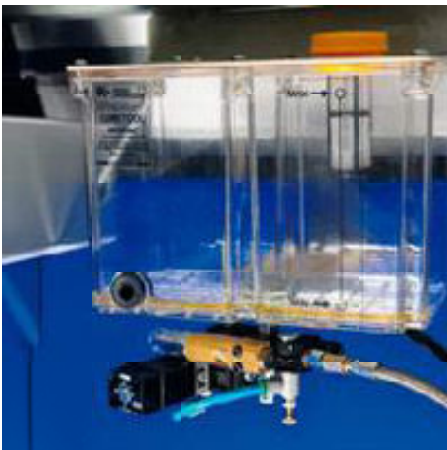

Spraying equipment

Your Format-4 can be optionally fitted with a spraying unit. High performance lubricating oil can be sprayed directly onto the saw blade, transported via piping from the spraying unit.



Adjustment tool storage

Integrated tool storage left of the saw blade - at arms reach, making machine operation more comfortable.

Technical specifications



| | | kappa 550 | kappa 550 x-motion | kappa 550 e-motion |
|---|----------|-------------------|--------------------|--------------------|
| Cutting height | | 202 mm | 202 mm | 202 mm |
| Tilting of saw-blade | | 90°-45° | 90°-45° | 90°-45° |
| Rip capacity | | 1000/1250/1600 mm | 1000/1250/1600 mm | 1000/1250/1600 mm |
| 7.5 HP (5.5 kW) | | S | S | S |
| 10.0 HP (7.5 kW) | | ○ | ○ | ○ |
| 15.0 HP (11.0 kW) | | ○ | ○ | ○ |
| Working height | | 890 mm | 890 mm | 890 mm |
| Length [L]** | 2800 mm* | 6500 mm | 6500 mm | 6500 mm |
| | 3200 mm* | 7300 mm | 7300 mm | 7300 mm |
| | 3700 mm* | 8300 mm | 8300 mm | 8300 mm |
| Width [W ₁] | | 1348/1954/2022 mm | 1348/1954/2022 mm | 1348/1954/2022 mm |
| Width [W ₂] | | 2037/3346 mm | 2037/3346 mm | 2037/3346/3721 mm |
| Extraction connection-Ø panel saw/saw guard (Overhead saw guard) | | 120/50 mm | 120/50 mm | 120/50 mm |

*Cutting length with outrigger at max. cutting height. **Details of the maximum travelling distance depending on the length of the sliding table.
 S ... Standard feature ○ ... option - ... Not available



Further information about the technical data, individual configuration options and all noise level values can be found on the internet at www.format-4.com

Space requirement

Scale
1:50

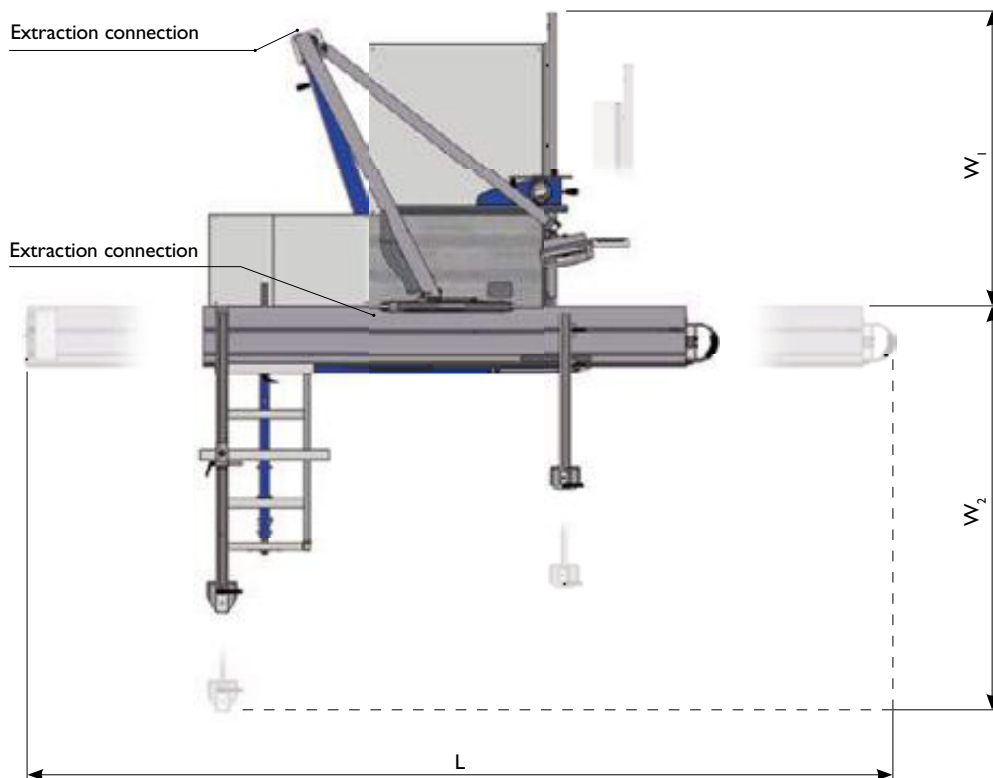

Actual machine may differ from symbolic image kappa 550, kappa 550 x-motion, kappa 550 e-motion

Dimensions given can vary if special equipment is used

kappa 400

For demanding woodworking



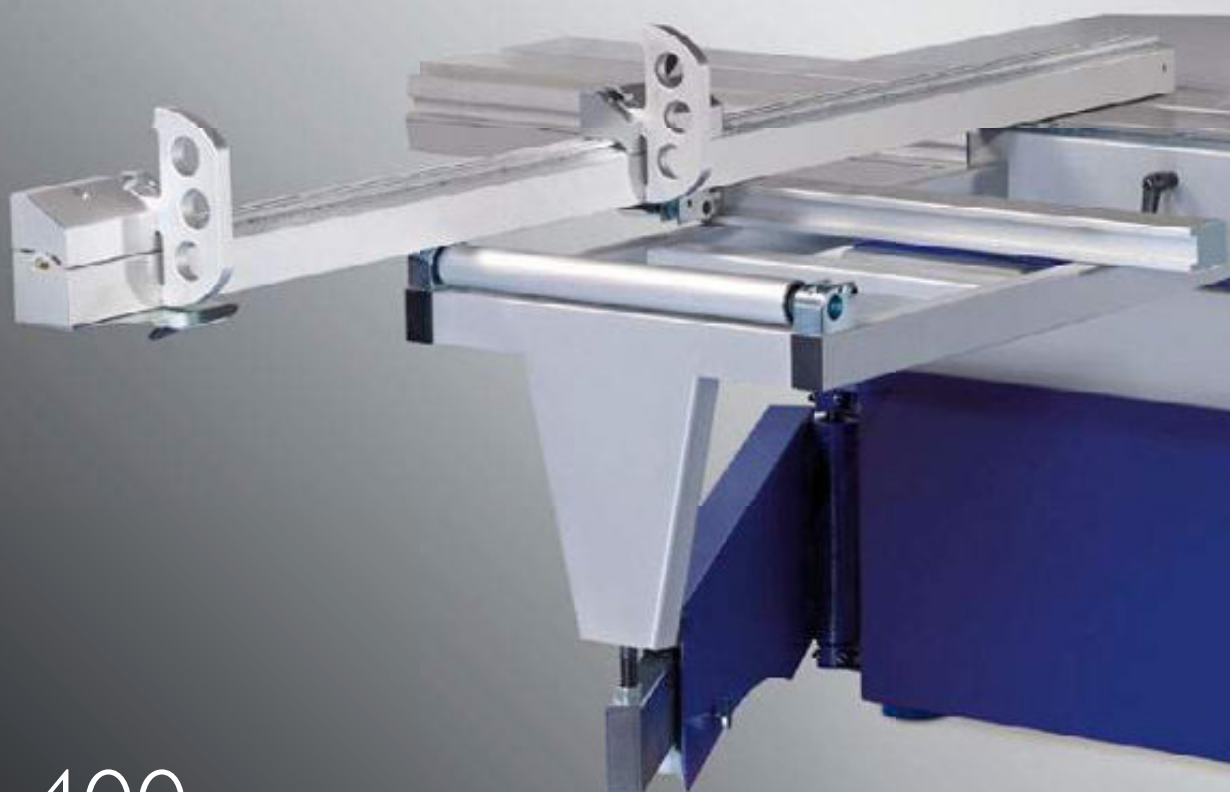

kappa 400

Optimum performance and a cutting height of 133 mm

Format-4 sliding table saws reflect our desire for perfection and the courage to find new solutions. Hidden inside the dynamically designed machine chassis you'll find advanced technology and a model of working convenience!

It allows for simple and comfortable use with the utmost safety. Uncompromising standards and performance with electrical height and angle adjustment of the saw unit, the operating panel with red LED-display for sawblade height and tilt, a tilting telescopic crosscut fence on the outrigger table for mitre cuts and much more.



- Cutting height 133 mm
- Aluminium sliding table with "X-Roll" precision guiding system
- Cutting length 2050–3700 mm
- Tooling compartment with space for 5 saw blades (option)
- Electronic height adjustment with LED display
- Electronic angle adjustment with digital LED display (0°–46°)

The machine illustrations may show optional equipment. Please refer to your individual quote for clarification on which options are included.



kappa 400 x-motion

Convincing in all areas

The Format-4 kappa 400 x-motion convinces in every area. Triple axis control, heavy duty circular saw unit, "X-Roll" sliding table, extreme ease of use, high precision and amazing value for money combine to form one of the best panel saws on the market.



- Cutting height 133 mm
- Aluminium sliding table with "X-Roll" precision guiding system
- Cutting length 2050–3700 mm
- Tooling compartment with space for 5 saw blades (option)
- CNC-drive control unit with 5.7"
- A choice between 3 or 5 axes control

The machine illustrations may show optional equipment. Please refer to your individual quote for clarification on which options are included.

The most important highlights at a glance

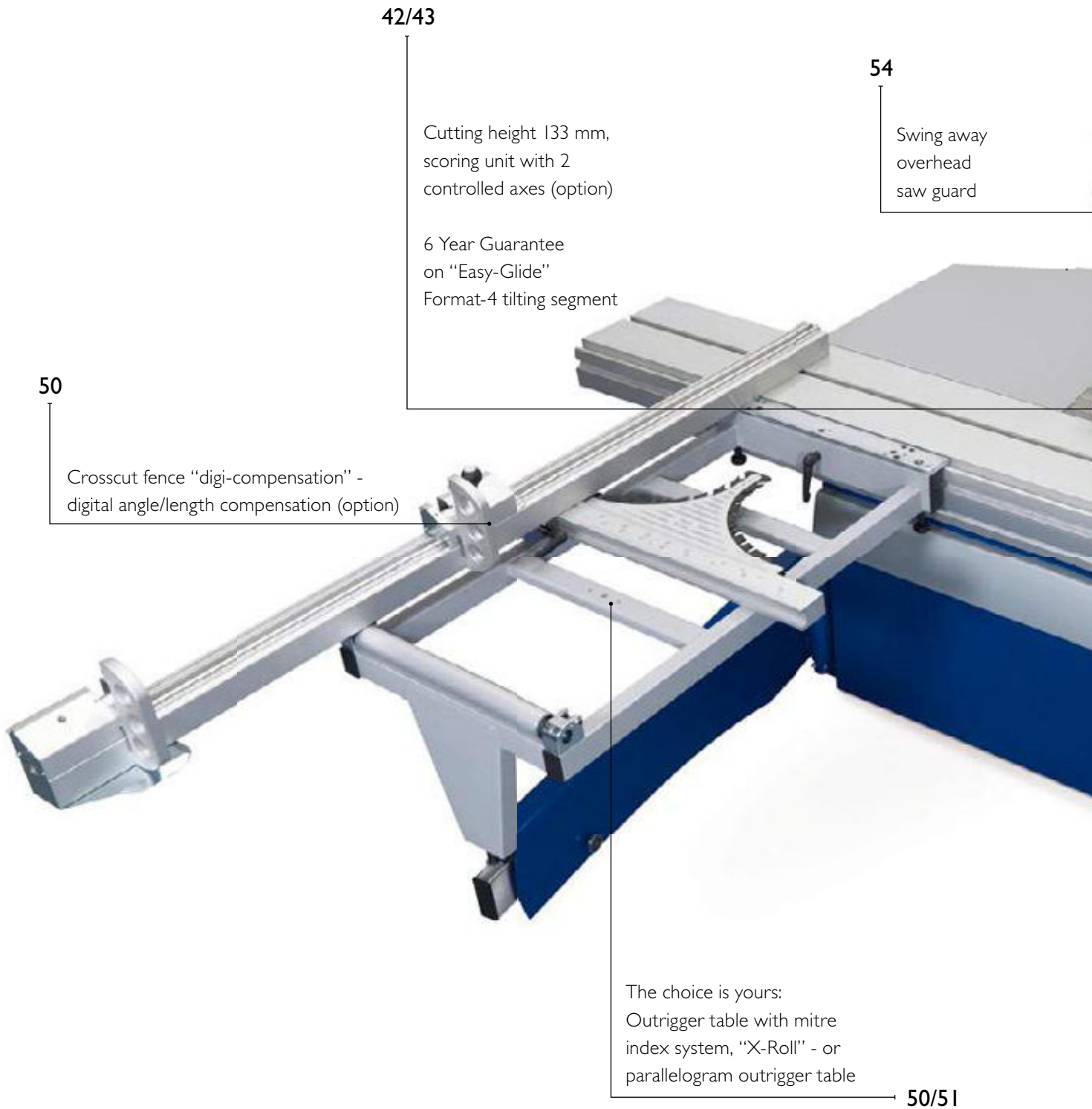

42/43

Cutting height 133 mm,
scoring unit with 2
controlled axes (option)

6 Year Guarantee
on "Easy-Glide"
Format-4 tilting segment

54

Swing away
overhead
saw guard

50

Crosscut fence "digi-compensation" -
digital angle/length compensation (option)

The choice is yours:
Outrigger table with mitre
index system, "X-Roll" - or
parallelogram outrigger table

50/51



46/47

Up to 5 positionable axes

45

Rip capacity 800 (1250) mm

Positioning control of the rip fence (x-motion)

48/49

Cutting length 2050–3700 mm “X-Roll” sliding table guiding system with 10 year warranty

Tooling compartment with space for 5 saw blades (option)

55

Remote “ON” button on the sliding table (option)

49

Precision circular saw unit, 133 mm cutting height

The newly developed Format-4 saw unit made from cast iron offers not only high performance and precision but also extreme smoothness and vibration absorption.

- Cutting height 133 mm with a 400 mm saw blade
- Electronic height adjustment with LED display
- Electronic angle adjustment with digital LED display
- Zero point tilt
- Oversized saw arbor with double bearing trunnions – Maximum motor power transfer with the Poly-V belt. The electronically balanced saw arbor with dual bearing seat system is powered via a Poly-V belt. Combined this results in an almost 100 % power transmission to the saw blade
- Maximum energy transfer from the large Poly-V belt bearing area
- 3-speed: 3500/4500/5500 rpm
- Optimal extraction with a completely enclosed, below table extraction system
- Dovetail guidance system of the height adjustment
- High precision double-sided trunnion support system
- **6 Year Guarantee** on "Easy-Glide" Format-4 tilting segment
 - High durability
 - Play-free tilt
 - Unaffected by dust
 - Completely maintenance free
 - No lubrication required
- Option: operates with dado tooling up to 20 mm in width

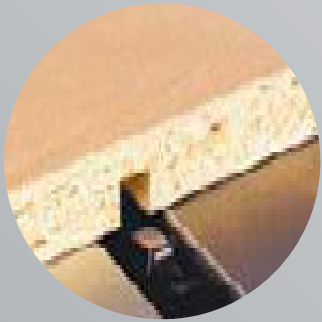

Slot cutting is possible with Format-4 panel saws. The use of adjustable dado tools, specifically developed by Format-4, can be used thanks to the removable circular saw flange and the table insert.

The saw shaft is enclosed in a massive cast iron housing. With the double bearing mounts, vibration free results are guaranteed. Power transfer from motor to sawblade is optimised through the use of a Poly-V belt.

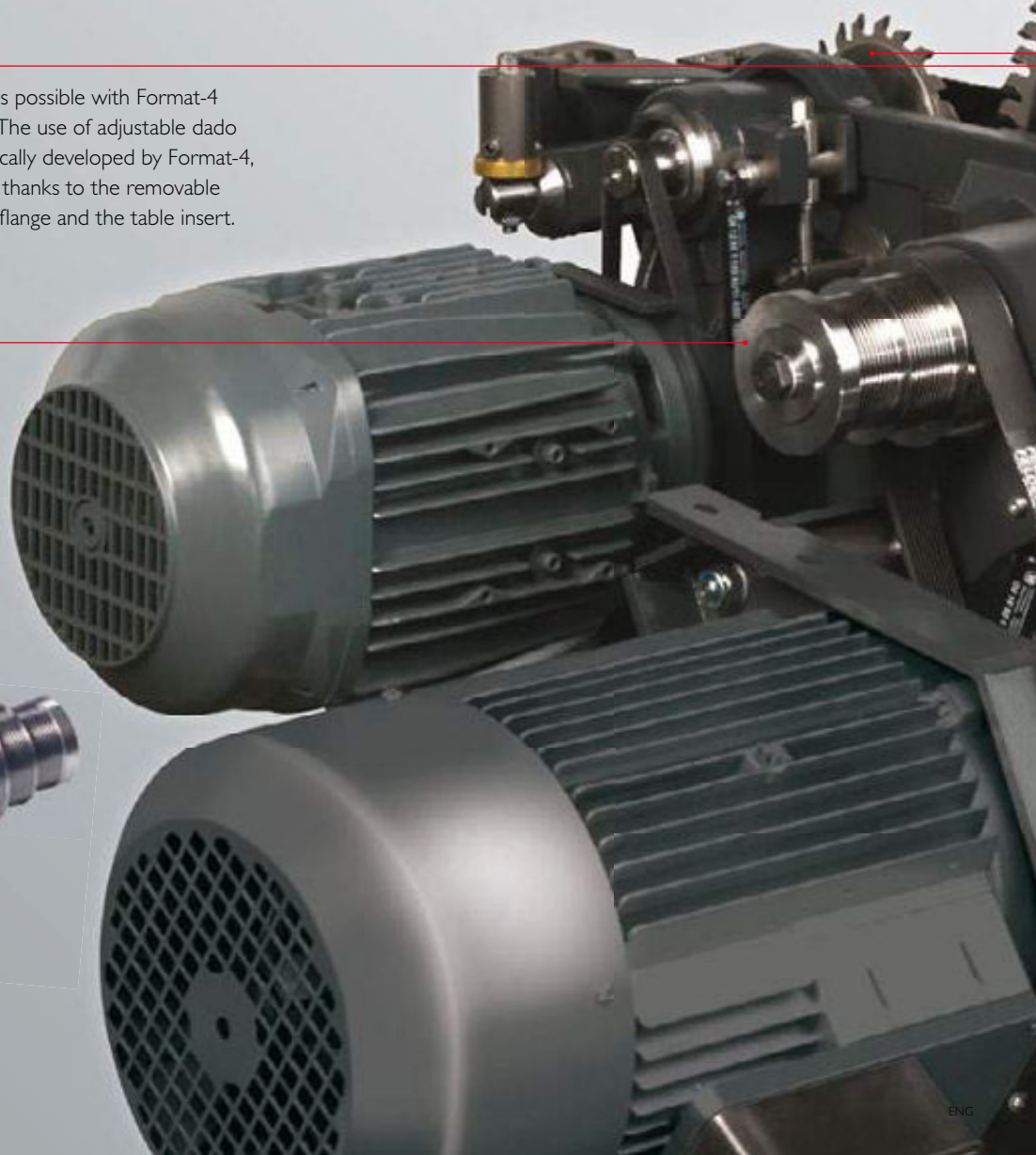

Scoring unit - you choose:

Classic: The height and lateral scoring blade settings can be manually adjusted from the top of the saw table.

Automatic: The scoring blade height setting is electrically adjusted with the turn of a knob, whereas the lateral settings are adjusted manually. Once the scoring blade is switched on, it moves automatically to its previously set vertical position and moves back completely under the saw table when switched off. Top of the range comfort!

NEW: The kappa 400 x-motion has the option of a scoring unit with 2 controllable axes:

- The vertical and horizontal position of the scoring blade in relation to the main blade can easily be set from the control panel.
- The information relating to the scoring blade can be saved in the tooling database appropriate to the saw blade. The next time the saw blade is required, the scoring blade automatically positions itself appropriate to that saw blade.

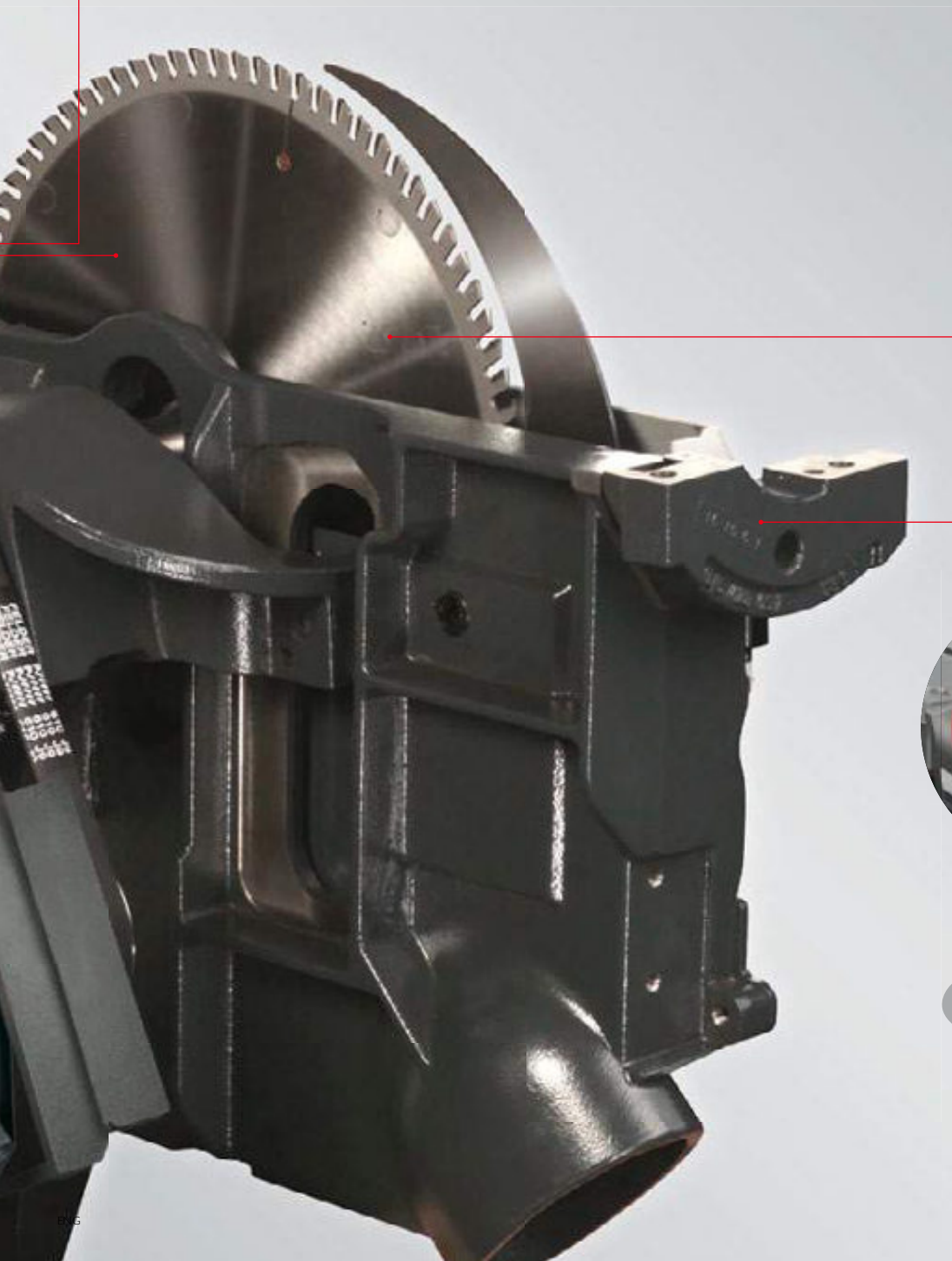

Zero point tilt



6

YEAR GUARANTEE
on "Easy-Glide"
Format-4
tilting segment

kappa 400, higher standard configuration at the best price



“Power-Drive” saw aggregate control

Electric height and angle adjustment

With “Power-Drive” you are getting an electrically controlled saw blade height and angle adjustment system, that is top class. You can select the cutting height and cutting angle using a quick-adjustment dial. Fine adjustment is carried out using a push button. Red LED display screens in the control panel show exact adjustment values. Whilst tilting, the height setting will be compensated - the LED screen will always show you the actual cutting height. The clearly laid out operating field informs you of the current speed of the saw blade.

The height of the scoring blade can also be electrically adjusted.

Up to 3 electrically controlled axes

- Saw blade height control
- Saw blade tilt control
- Height adjustment of the scoring blade (Option)

Rip fence



Standard equipment

The highly visible scale on the saw table executes accurate settings, and the rip fence has a tilt and inversion function.

- Table scale as standard
- Fine adjustment as standard



Option

Rip fence of the highest quality

The single handed adjustment system ensures quick and accurate setting of the rip fence. A fine adjustment facility is included. The rip capacity amounts to 800 mm or optionally 1250 mm. The easy to read rip scale is perfectly integrated into the saw table. The aluminium rip fence plate can be swung away to optimise the feed of workpieces.

Electronic digital indicator display, readable from every position

The integration of the electronic digital display on the rip fence allows for the reading of the cutting width to one tenth of a millimetre. The display can be rotated up to 90° to suit the working position. Additional features, such as fine progressive adjustments in increments of 0.1mm make precision cutting reality.

Further highlights electronic digital display:

- Brightly illuminated red LED display facilitates the reading of values
- No batteries are required due to a direct connection to the machine's power supply
- Recognises automatically whether the fence is in the vertical or horizontal position
- Measurement compensation of the saw blade tooth width

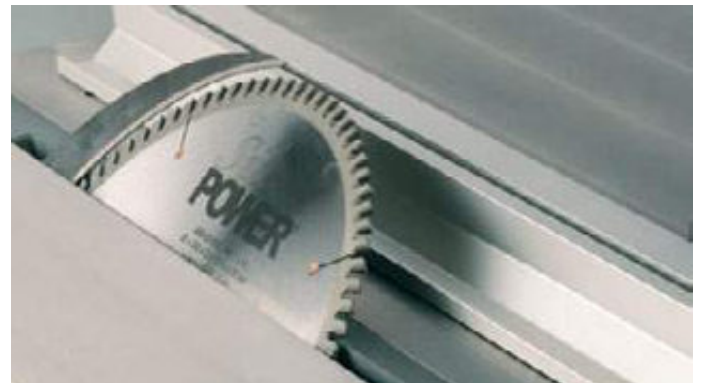

When working with narrow and thin cuts of wood with the saw blade at an angle, the rip fence can be placed face down to improve operator comfort and avoid collision with the saw blade. The rip fence can also be tilted underneath the table.

kappa 400 x-motion, up to 5 positionable axes



CNC machine control with a 5.7" (145 mm) colour LCD

Overhead control panel

- Automatic cutting depth compensation when tilted
- Saw speed display
- Control for variable saw blade speed (Option)
- Positioning control of the rip fence with automatic measurement correction when the saw blade is at an angle
- All possible functions also available in touch control mode
- 99 memory positions in the tooling database
- + Program with stored functions (grooves, row of grooves, rabbets, wrong mitre, mitred cuts, calculator)

Up to 5 positionable axes

New control features on the kapa 400 x-motion

- Saw blade height control
- Saw blade tilt control
- Positioning control of the rip fence
- 2 axes scoring unit optionally available
- 9x 99 cutting programs, incremental measurement function – just two of the numerous control features. A high performance 3 axis controlled machine with overhead control panel

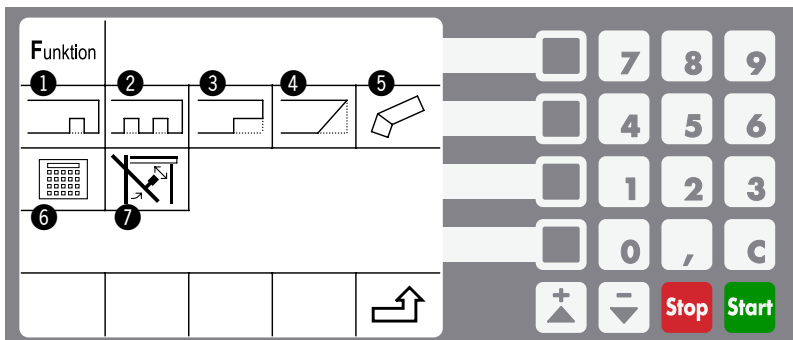

Special functions, standard on the x-motion

These special functions are always recalculated for the currently used tool and converted into a program (cutting sequence).

- ① Grooves
- ② Notches
- ③ Rabbets
- ④ Diagonal cuts
- ⑤ Wrong Mitre
- ⑥ Calculator
- ⑦ Compensation of length for mitred cuts

Positioning control of the rip fence

The rip fence is positioned by a motor and runs via a dust-free integrated ball spindle in the saw table. Fence positioning is accurate to 0.1 mm, this combined with fast positioning speed and that the saw blade height and tilt can be adjusted simultaneously, ensures precision and significant reduction in working time.

- Automatic measurement correction when the spindle fence is horizontal
- Rip fence park position
- No collision possible with the saw blade due to the coordination of the tool database by the positioning control
- The rip fence can be swung away at any point across the full rip capacity
- Rip capacity standard 1250 mm (800 mm as an option without surcharge)





Sliding table “X-Roll”, 10-year guarantee

A masterpiece of engineering -
The ultimate in precision and smoothness.

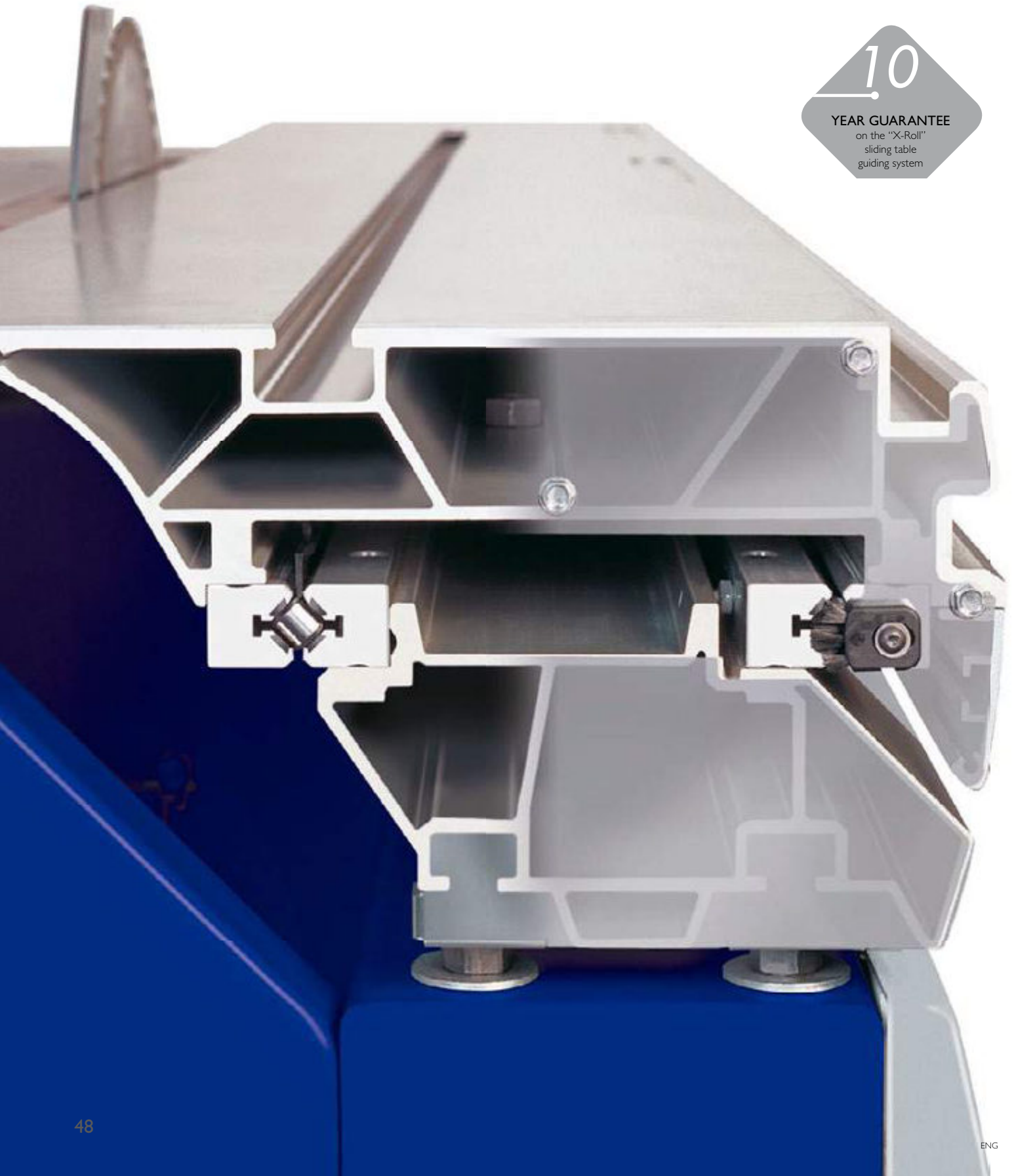

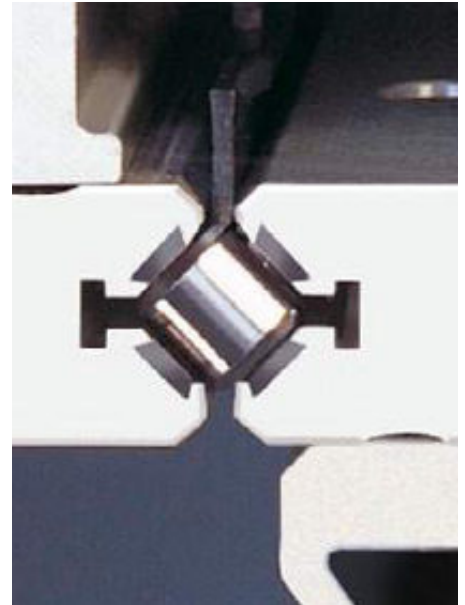

This precision guiding system will carry maximum loads without compromising the smooth and accurate stroke of the sliding table. The "X"-configuration of the roller bearings optimally distributes workpiece weight to all sides. With a roller bearing system, the full width of the bearing is in contact with the guiding track. With no single point of contact between the bearing and the guiding track as found on conventional ball bearing systems, the roller bearing will never wear a groove into the guiding track. This ensures play-free guiding for the lifetime of the machine. The "X-Roll" system is backed with a 10-year factory guarantee.



Durable

Long lasting tracks with the Format-4 linear guiding system. No pressure points due to mechanical roller suspension.

Maintenance-free

Maintenance-free and dust protected due to covered guiding tracks positioned sideways on the inside.

Stable

Extremely warp resistant due to the solid profile construction.

Protected from dust

Dust protection due to the special "12-fold" wiper system.

- 4 wiping brushes
- 8 silicon wipers

**"X-Roll",
making a difference:**

- Extremely smooth running and durable guiding system! The use of roller bearings ensure that there is no single point of contact between the bearings and the guide track!
- The dust resistant construction of the 3-way dust protection system ensures dust free and clean guide tracks.
- Hardened and ground bearing tracks.
- 10 Year guarantee: on the "X-Roll" sliding table guiding system.



As an option, it is also possible to equip the saw with the wireless push button control "ON" switch of the main blade and scoring blade to the sliding table, speeding up the work process further.

Outrigger tables, the choice is yours ...



“X-Roll” outrigger table

The support rail is moved along a “X-Roll” guiding system and is fast and micro-adjustable. The LED display enables you to set the required angle to one tenth of a degree. The telescopic crosscut fence can be positioned at the front as well as the back of the outrigger. The angle/length compensation is carried out using either a Nonius scale or “digi-compensation”. The “X-Roll” outrigger table combines the advantages of the standard outrigger and the parallelogram outrigger at an incredibly attractive price:

- Accurate 90° stop
- Easy setting of the mitre angle
- Large supporting surface
- Increased stability due to a welded framework



NEW: “digi-compensation” -

Digital angle/length compensation

On both the “X-Roll” and Parallelogramm outrigger tables the exact position of the crosscut stop is calculated using the angle setting information which is transferred to the stop via radio signal.



Parallelogram outrigger table

The new and solidly built parallelogram outrigger table enables infinitely variable mitre cuts from -45° up to $+45^\circ$. The surface available for the workpiece remains the same regardless of the angle setting. The digital display of the angle setting is accurate to 1/100th of a degree. The angle/length compensation is carried out using either a Nonius scale or "digi-compensation".



Precision mitre guide index system outrigger table

Time consuming angle approximations as well as reading and calculation errors are a thing of the past. Adjust and lock in place without losing time - the highly precise pin index enables the accurate manufacturing of multiple sided pieces with ease.

Additional indexes at intervals of 5 degrees from 15 to 45 are available by sliding out and back into the one required. Each index point is equipped with a length compensation that can be fine adjusted if required.

Outrigger table

The outrigger table with workpiece roller is solidly built. 8 guide rollers running on ball bearings within the outrigger arm ensure that the unit is incredibly smooth, even when supporting heavy loads.

90° guarantee

The telescopic stop is fixed into the 90° position with one single movement. The bayonet catch integrated on the outrigger table ensures continuous accuracy of the right angle.



Digital accuracy

On request, we can equip your Format-4 with the digital telescopic fence, this includes an integrated electronic digital scale with values correct to 0.1 millimeter. Additional functions, for example the setting of incremental measurements, make your daily working life easier.

Telescopic crosscut fence

The telescopic fence enables crosscuts of up to 3200 mm. Top class engineering and ease of use are features which are a part of the standard equipment. The scale and the magnifying glass on the fence-stop ensure precise adjustments and settings from the operating area.

Precision mitre index system



Mitre indexing system with length compensation

No reading errors due to scales and vernier. No time-wasting with arduous approximations of angle values. The advantage of the Format-4 degree index is that the stop is set and fixed without losing time or making reading errors. Highly precise index positions allow for the accurate production of polygons, e.g. 5.625° (32 sided), 11.25° (16 sided), 22.5° (8 sided). In addition, index positions at 15°, 20°, 25°, 30°, 35°, 40° and 45° can be used when working in slide to cut or push to cut mode. Every index position is equipped with a length compensator. The highly precise Format-4 degree index system is adjusted at the factory. Every index position also has individual fine adjustment. This cost effective index system integrates well into the machine design and will increase your productivity. (Option)



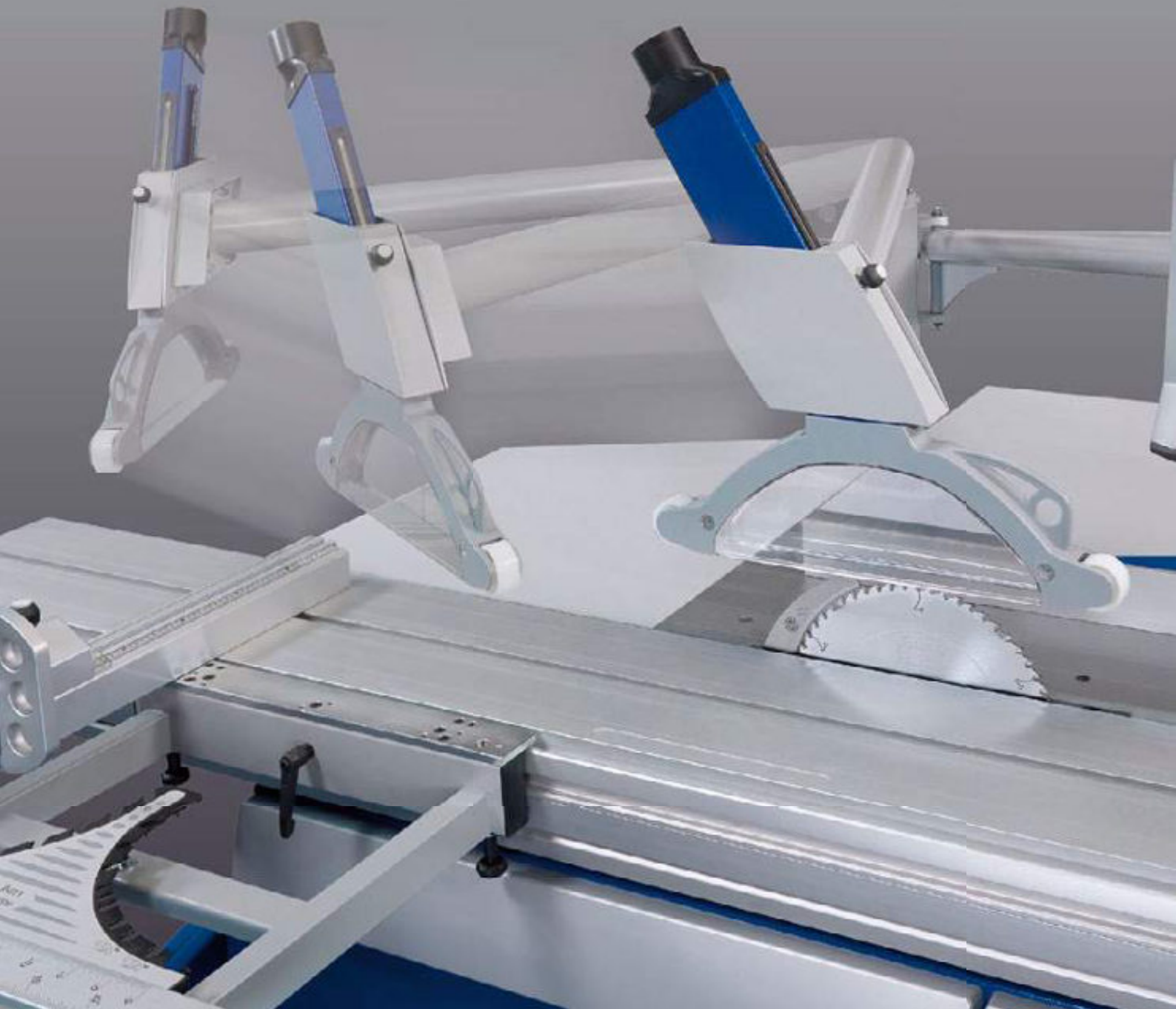

Swing away overhead saw guard

The overhead saw guard is height adjustable and can be swung away.

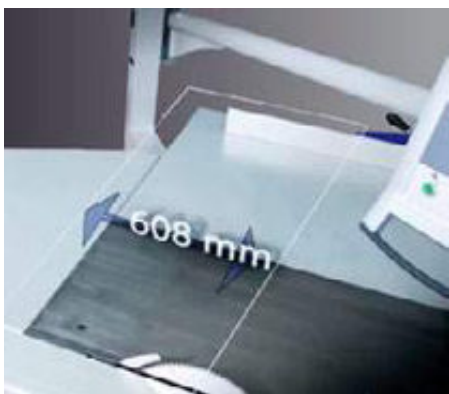

The max. free cut for especially wide workpieces is 608 mm.

Options that impress!



Tool compartment

- Integrated tooling storage in the machine chassis
- Storage room for 5 saw blades, max. dia. 400 mm

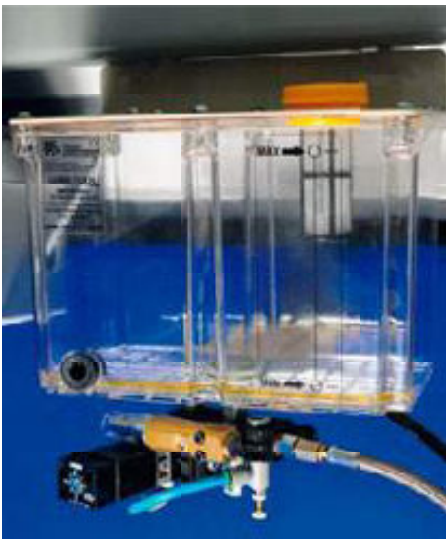

Spraying equipment

Your Format-4 can be optionally fitted with a spraying unit. High performance lubricating oil can be sprayed directly onto the saw blade, transported via piping from the spraying unit.



Adjustment tool storage

Integrated tool storage left of the saw blade - at arms reach, making machine operation more comfortable.

Technical specifications



| | | kappa 400 | kappa 400 x-motion |
|--|----------|--------------|--------------------|
| Cutting height | | 133 mm | 133 mm |
| Tilting of saw-blade | | 90°-45° | 90°-45° |
| Rip capacity | | 800/1250 mm | 800/1250 mm |
| 5.5 HP (4,0 kW) | | S | S |
| 7.5 HP (5,5 kW) | | O | O |
| Working height | | 890 mm | 890 mm |
| Length [L] ** | 2050 mm* | 4647 | 4647 |
| | 2500 mm* | 5547 | 5547 |
| | 2800 mm* | 6147 | 6147 |
| | 3200 mm* | 6947 | 6947 |
| | 3700 mm* | 8030 | 8030 |
| Width [W ₁] | | 1074/1509 mm | 1212/1672 mm |
| Width [W ₂] | | 1830-3345 mm | 1830-3345 mm |
| Extraction connection-Ø panel saw/saw guard (Overhead saw guard) | | 80/120 mm | 80/120 mm |

*Cutting length with outrigger at max. cutting height, **Details of the maximum travelling distance depending on the length of the sliding table.;
 S ... Standard feature O ... option - ... Not available



Further information about the technical data, individual configuration options and all noise level values can be found on the internet at www.format-4.com

Space requirement

Scale
1:50

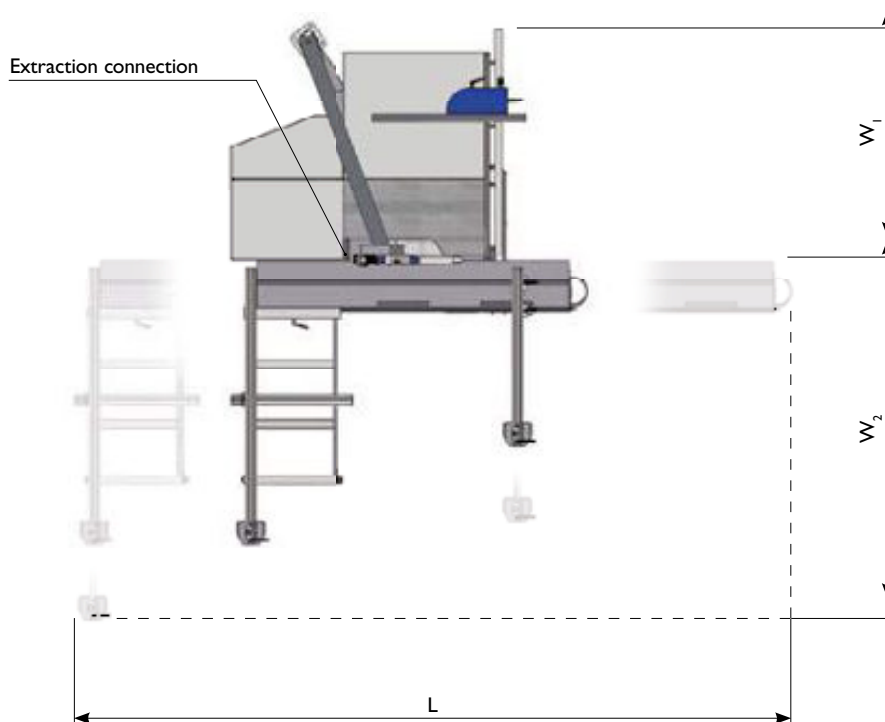

Actual machine may differ from symbolic image kappa 400, kappa 400 x-motion

Dimensions given can vary if special equipment is used

plan 5 l

Uncompromised premium quality





plan 51

A top of the range surface planer

Long, solid cast iron planer tables with easy, quick adjustment of the cutting depth from the planer table infeed position. The tilting planer fence and the Format-4 cutterblock system make your plan 51 a top class surface planer.



- Surface planing width 510 mm
- Surface planer table length 2250 mm
- 4 knife Felder system cutterblock as standard, optional 4 knife-standard blade cutterblock, Silent-POWER® spiral cutterblock or Tersa knife system

The machine illustrations may show optional equipment. Please refer to your individual quote for clarification on which options are included.

The most important highlights at a glance

63

Quick change, self-setting,
self-aligning knives

65

Planer guard

Solid cast iron
planing table

64





65

Planing fence from 90°–45°
fully adjustable

Aigner combination fence
(optional)

64

Quick adjustment of the depth
of cut. Read out located in an
ergonomical position



Revolutionary: Silent-POWER® cutterblock

Sensationally quiet planing and money saving!

Exclusive for planer/thicknessers from the Felder Group

The Silent-POWER® Spiral cutterblock reduces noise emissions by more than half when planing. The continuous pulling cut ensures tear-free results when planing all types of wood. With this revolutionary new development from Felder you are obtaining all of the advantages of a spiral cutterblock at considerably lower operating, investment and adjustment costs.

The advantages of the Silent-POWER® cutterblock at a glance ...

- Sensationally quiet, noise emissions halved
- Blade life up to 20 times longer
- Four highly precise cutting edges on each knife
- Optimised chip extraction and reduced chip volume
- Tear free planing results
- Reduced power consumption when compared to similar systems



Smaller chips - compact better

The optimised extraction hood ensures that the noticeably shorter chips are effectively extracted and land considerably more compact in the dust bags.

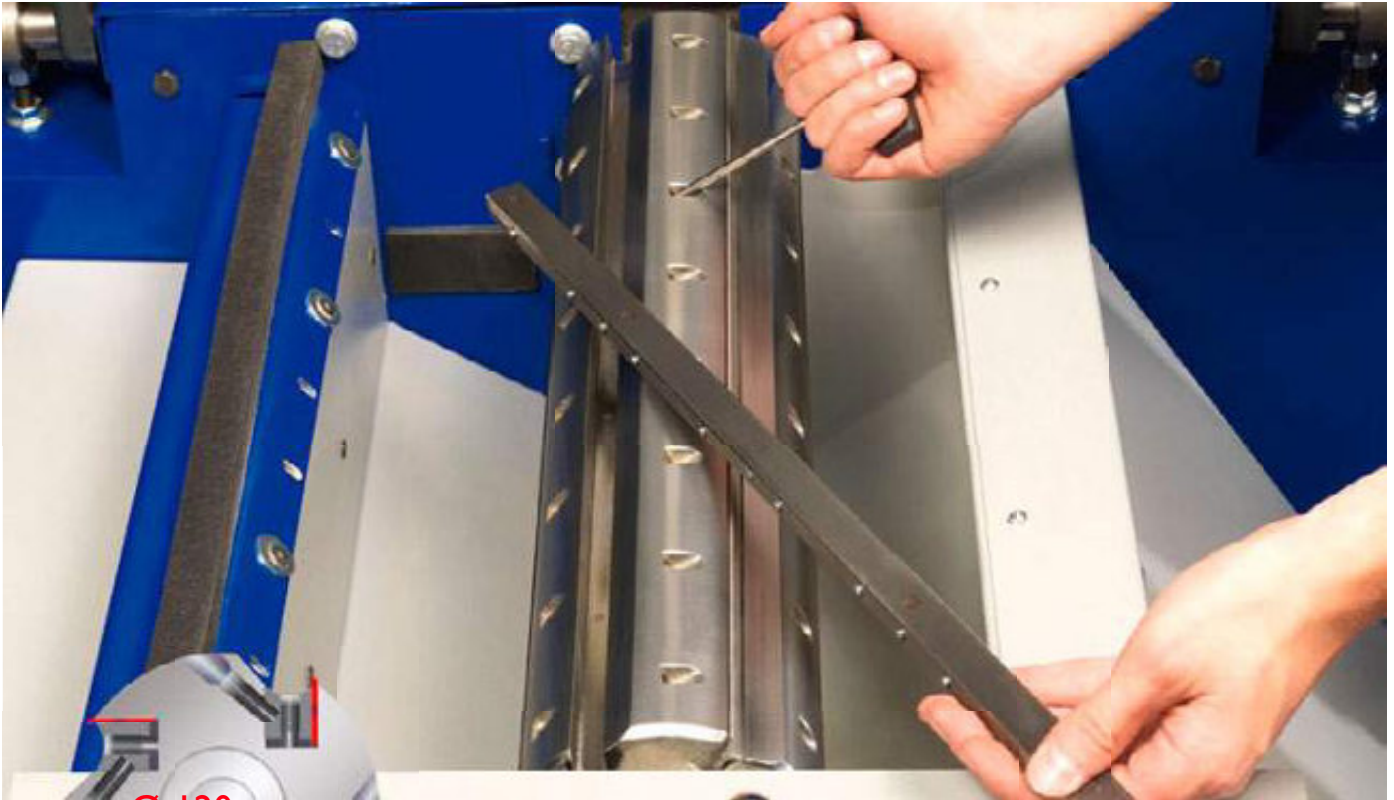

Surface planing with a 4-knife cutterblock

The plan 5I featuring the Format-4 system cutterblock with a diameter of 120 mm and 4 knives, outstanding performance and precision.

For decades the Format-4 system with double sided disposable planer knives has proved its worth. Perfectly manufactured and adjusted in the factory, there is no need to adjust the planer knives and no expensive adjusting tools have to be purchased.

It's simple to change the planer knives. In less than a few minutes you can change all of the Format-4 planer knives and once they have been tightened, they are ready for use! As an option you can also equip your Format-4 with a Silent-POWER® spiral cutterblock, or with Standard or Tera knife systems.

Planer knife adjustment without tools – standard with your FORMAT-4!

- 4-knife cutterblock
- Quick and effortless knife change
- Self-aligning knives are perfectly set each and every time!
- No resin buildup on the clamping bolts.
- Extremely quiet operation due to the enclosed design
- Excellent durability of knife edges
- Cost savings due to the 2 sided low cost knives

Details that impress!

Patented planer adjustment system

Accurate adjustment is obtained with the patented planer adjustment system, which incorporates lateral prismatic guide rails.

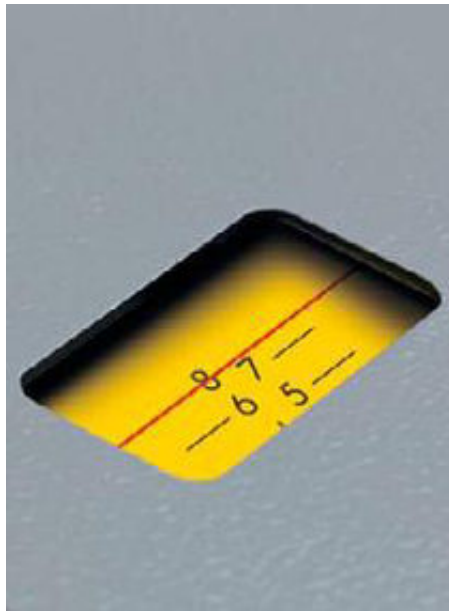
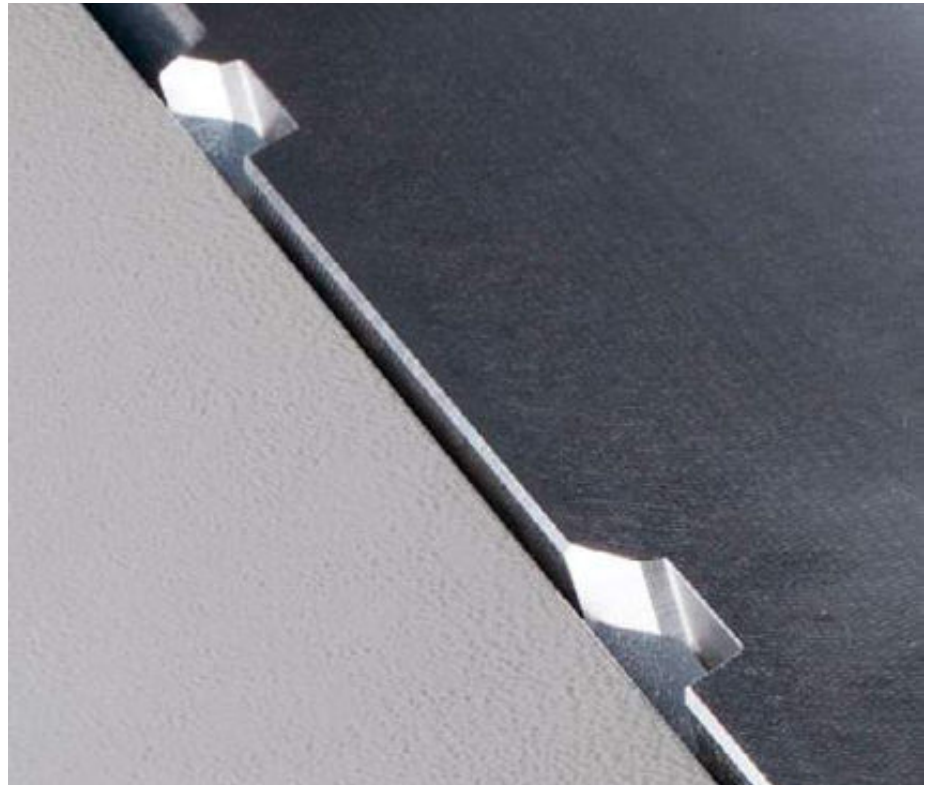

The depth of cut can be set to any depth up to 8 mm. Using the integrated magnifying glass you can view the set depth and achieve the exact results that you are looking for.



Quick and accurate adjustment of cutting depth from the operator side of the infeed table.

Professional planer fence

The planer fence: A masterpiece of engineering providing stability, precision and performance!

The planing fence can be tilted to any angle between 90° and 45°. There are positive stops at 90° and 45°. The exceptional space-saving design of the planer fence makes it possible to place your planer directly against the workshop wall and still use the entire planing width.

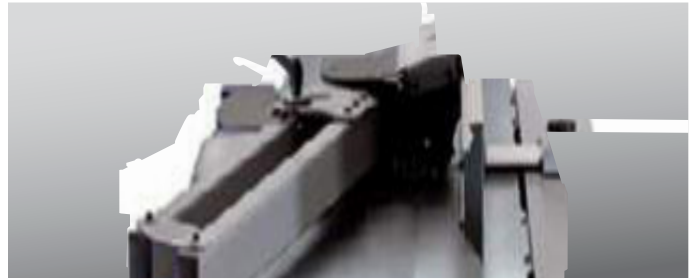

Comfort planer guard
Folds in two places. This ensures that it does not restrict you whilst planing.



Aigner combination fence
The auxiliary fence is built into the planer fence ensuring that it does not get in the way when the fence is at an angle.



Technical specifications



| | plan 51 |
|--|-----------------|
| Planer table length | 2250 mm |
| Maximum depth of cut | 8 mm |
| Surface planing width | 510 mm |
| 5.5 HP (4,0 kW) | S |
| 7.5 HP (5,5 kW) | O |
| 10.0 HP (7,35 kW) | O |
| Height (closed) | 1270 mm |
| Height (open) | 1650 mm |
| Working height | 890 mm |
| Length [L] | 2252 mm |
| Width [W] | 965-1642 mm |
| Extraction connection-Ø Surface planer | 140 mm |
| Acoustic noise level [dB (A)] in accordance with EN ISO 3746 when switched on but not running*** | 85 ¹ |
| Acoustic noise level [dB (A)] in accordance with EN ISO 3746 when running*** | 92 ¹ |
| Acoustic noise level at the workstation [dB (A)] in accordance with EN ISO 11202 when switched on but not running*** | 73 ¹ |
| Acoustic noise level at the workstation [dB (A)] in accordance with EN ISO 11202 when running*** | 82 ¹ |

***An allowance must be made to compensate for tolerances with the specified emission values. K= 4 dB (A);
 S ... Standard equipment O ... option - ... Not available; ¹ ... measured using the SilentPOWER[®] spiral cutterblock



Further information about the technical data, individual configuration options and all noise level values can be found on the internet at www.format-4.com

Space requirement

Scale
 1:50

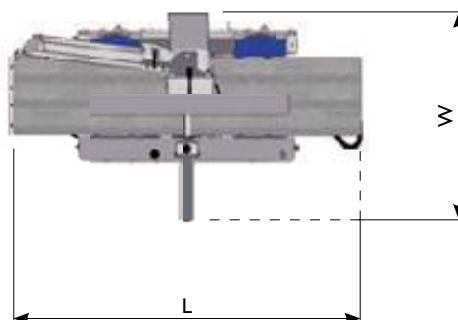

Actual machine may differ from symbolic image profil 51

Dimensions given can vary if special equipment is used

plan 5 L

3 metre planer table length

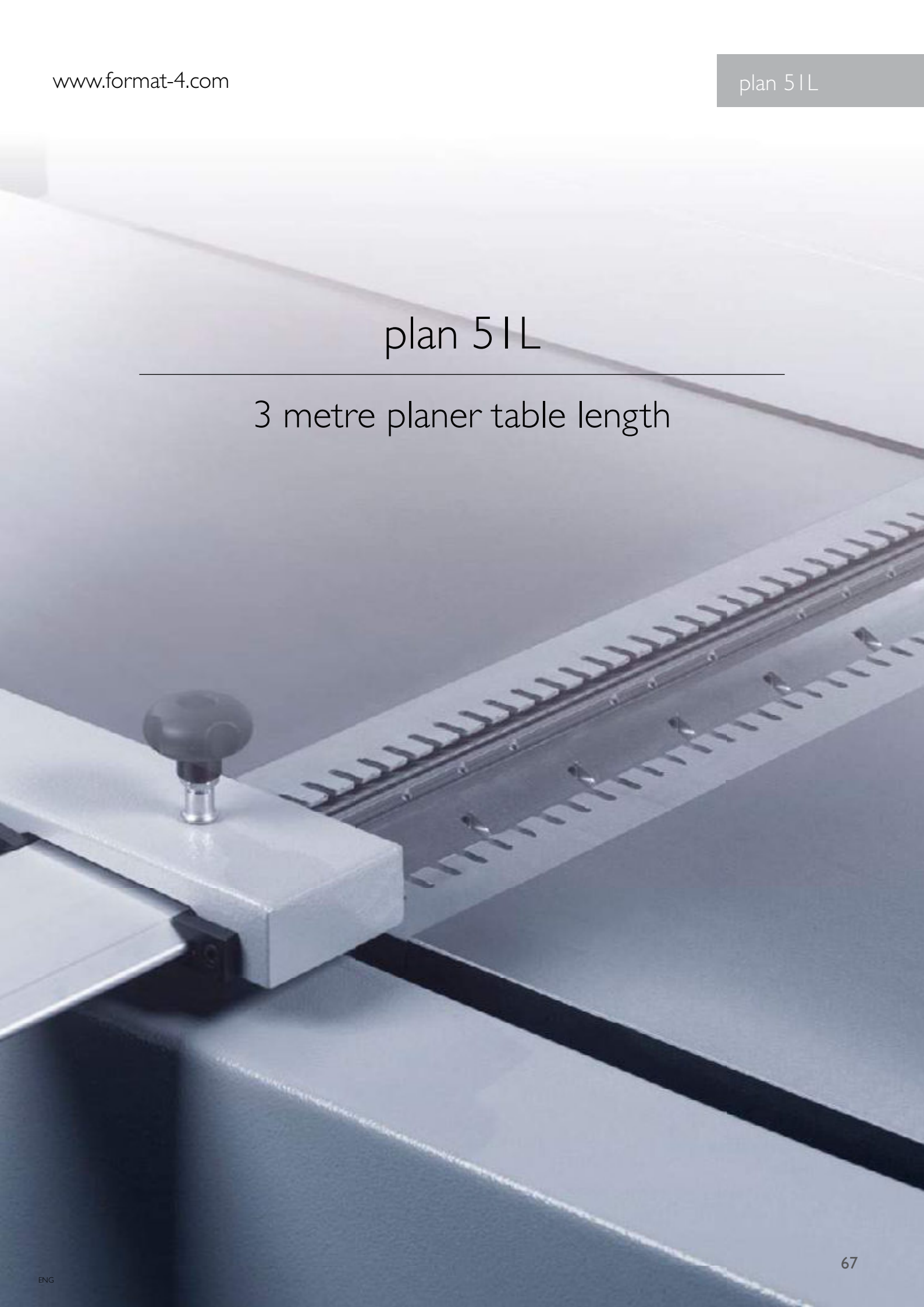



plan 51L

The Surface Planers

The heavy duty plan 51L planer impresses at first glance with its 3000 mm planing table. The infeed table alone is 1800 mm in length, more than enough support surface for large workpieces. The solid, ribbed planing table, 510 mm planing width and a modern machine concept fulfils the highest of requirements of the professional user.



- Surface planing width 510 mm
- Surface planer table length 3000 mm
- 4-knife Felder system cutterblock as standard, optional 4-knife-standard blade cutterblock, Silent-POWER® spiral cutterblock or Tersa knife system

The machine illustrations may show optional equipment. Please refer to your individual quote for clarification on which options are included.

The most important highlights at a glance

72

Quick change, self-setting,
self-aligning knives

73

Quick adjustment of the depth
of cut at the push of a button



74

Professional planer fence stability,
precision and space saving with the
Format-4 planing fence

74

Solid cast iron planing table
Large supporting surface

Cutterblock

Knife adjustment without tools

The Format-4 plan 51L is equipped with a 4-knife Format-4 system cutterblock as standard. As an option you can also equip your Format-4 with a Silent-POWER® spiral cutterblock, or with Standard or Tersa knife systems.

Planer knife setting without tools – standard with your FORMAT-4!

- 4 knife cutterblock
- Quick and effortless knife change
- Self-aligning knives are perfectly set each and every time!
- No resin buildup on the clamping bolts.
- Extremely quiet operation due to the enclosed design
- Excellent durability of knife edges
- Cost savings due to the 2 sided low cost knives

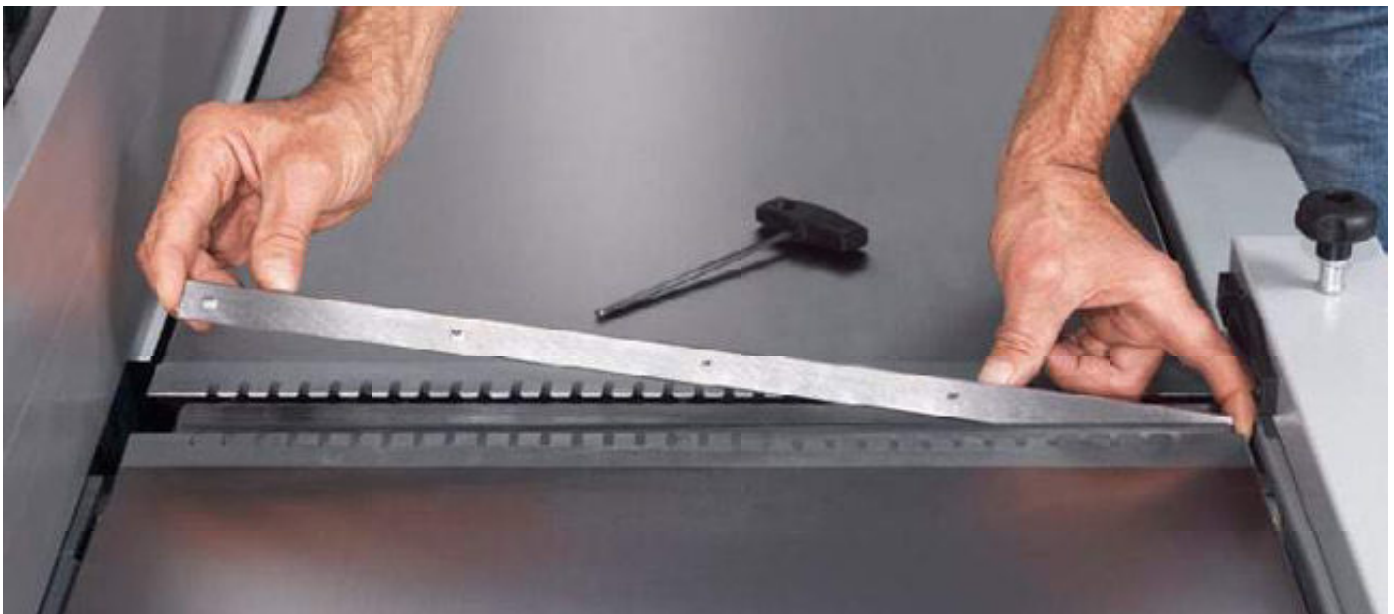
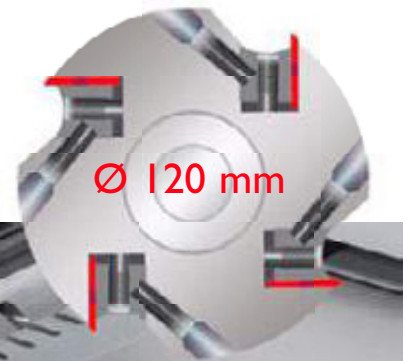

Details that impress!

Planer table adjustment with "Power-Drive"

The "Power-Drive" option enables electrical adjustment of cutting depth up to 8 mm of infeed planer table, all at the touch of a button! (option)



Quick and accurate adjustment of cutting depth from the operator side of the infeed table.

Professional planer fence

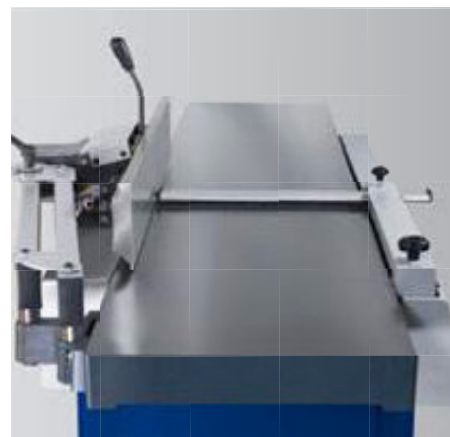
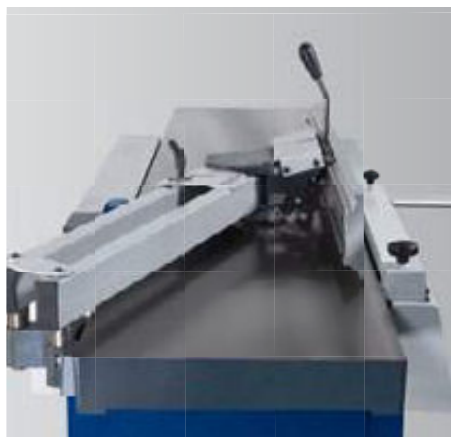

The planer fence:

A masterpiece

The planer fence is a masterpiece of stability, precision and economy of space. Due to its space-saving structure, the Format-4 plan 5 IL can be installed directly against the workshop wall and the entire planing width can be used.



Comfort planer guard

Maximum operational safety and an unprecedented ease of use. The space saving planer guard integrated into the machine chassis also stabilises the workpiece when planing and bevelling the narrow edge. (option)



Aigner combination fence

The auxiliary fence is built into the planer fence ensuring that it does not get in the way when the fence is at an angle.

Bringing together what belongs together

plan 51L + exact 63

The exact 63 thicknesser and the plan 51L surface planer with its space-saving planer fence make for the perfect machine combination.



Technical specifications



| | plan 51L |
|--|-----------------|
| Planer table length | 3000 mm |
| Maximum depth of cut | 8 mm |
| Surface planing width | 510 mm |
| 5.5 HP (4.0 kW) | S |
| 7.5 HP (5.5 kW) | O |
| Height (closed) | 1270 mm |
| Height (open) | 1650 mm |
| Working height | 890 mm |
| Length [L] | 2976.5 mm |
| Width [W] | 1662 mm |
| Extraction connection-Ø surface planer | 140 mm |
| Acoustic noise level [dB (A)] in accordance with EN ISO 3746 when switched on but not running*** | 85 ¹ |
| Acoustic noise level [dB (A)] in accordance with EN ISO 3746 when running*** | 93 ¹ |
| Acoustic noise level at the workstation [dB (A)] in accordance with EN ISO 11202 when switched on but not running*** | 74 ¹ |
| Acoustic noise level at the workstation [dB (A)] in accordance with EN ISO 11202 when running*** | 84 ¹ |

***An allowance must be made to compensate for tolerances with the specified emission values. K= 4 dB (A);
 S ... Standard equipment O ... option - ... Not available; ¹ ... measured using the Silent-POWER® spiral cutterblock



Further information about the technical data, individual configuration options and all noise level values can be found on the internet at www.format-4.com

Space requirement

Scale
 1:50

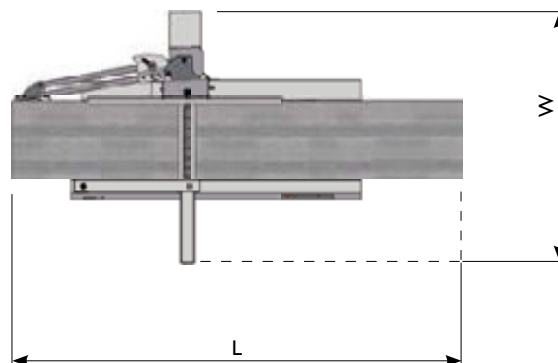

Actual machine may differ from symbolic image plan 51L

Dimensions given can vary if special equipment is used

exact 51
exact 63

Power - comfort - precision



exact 5 l
exact 63

Precision and comfort for heavy use

Optimised for maximum performance these thicknessers are a complete package of absolute top performance and precision. Innovative control elements and heavy duty, solid precise machine components convince with first class manufacturing and durability at the forefront. Tried and tested Format-4 system components such as the solid thickening bed, exact setting accuracy and the four trapezoidal spindles combine together with innovative new developments such as the Silent-POWER® spiral cutterblock to offer a whole new dimension of planing finish quality. Professional machine operators from small and big companies all the way through to industry will profit from perfect planing results.



exact 51

- Thicknessing width 504 mm
- Thicknessing height 3–300 mm
- Variable speed 5–20 m/min
- Cutterblock diameter 120 mm
- 4 knife Felder system cutterblock as standard, optional 4 knife-standard blade cutterblock or Silent-POWER® spiral cutterblock
- Electirical position control

exact 63

- Thicknessing width 630 mm
- Thicknessing height 3–300 mm
- Variable speed 5–20 m/min
- Cutterblock diameter 120 mm
- 4 knife Felder system cutterblock as standard, optional 4 knife-standard blade cutterblock or Silent-POWER® spiral cutterblock
- Position control

The machine illustrations may show optional equipment. Please refer to your individual quote for clarification on which options are included.

The most important highlights at a glance

82/83

Cast iron
cutterblock housing

86

Machine control with
"Power-Drive" or as an option,
also with "Digi-Drive"

84

Four different knife systems
to choose between

103

The large 900 mm thickening table can
be lengthened with a table extension on
the outfeed side and a workpiece roller on
the infeed side. This results in an overall
length of 1500 mm!

The infeed roller comes as an option with
automatic lubricating agent applicator

87

Scissor lift table on the outfeed side



Optional, adjustable under table rollers

87



... the perfect machine combination
exact 63 + plan 51

Cutterblock

The cast iron bearing seats for the cutterblock can easily handle any type of work. As an option, the machine can be equipped with rubber-coated in- and outfeed rollers, to cope with workpieces of different thickness.

Segmented pressure bar on the infeed side

Kickback guard

Segmented steel infeed roller, spiral-toothed Ø 85 mm (Option)

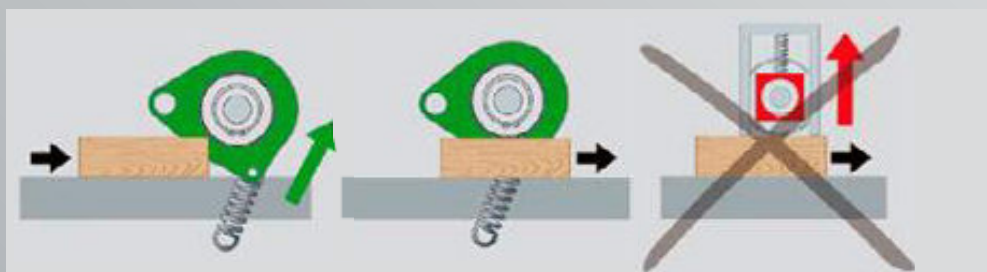

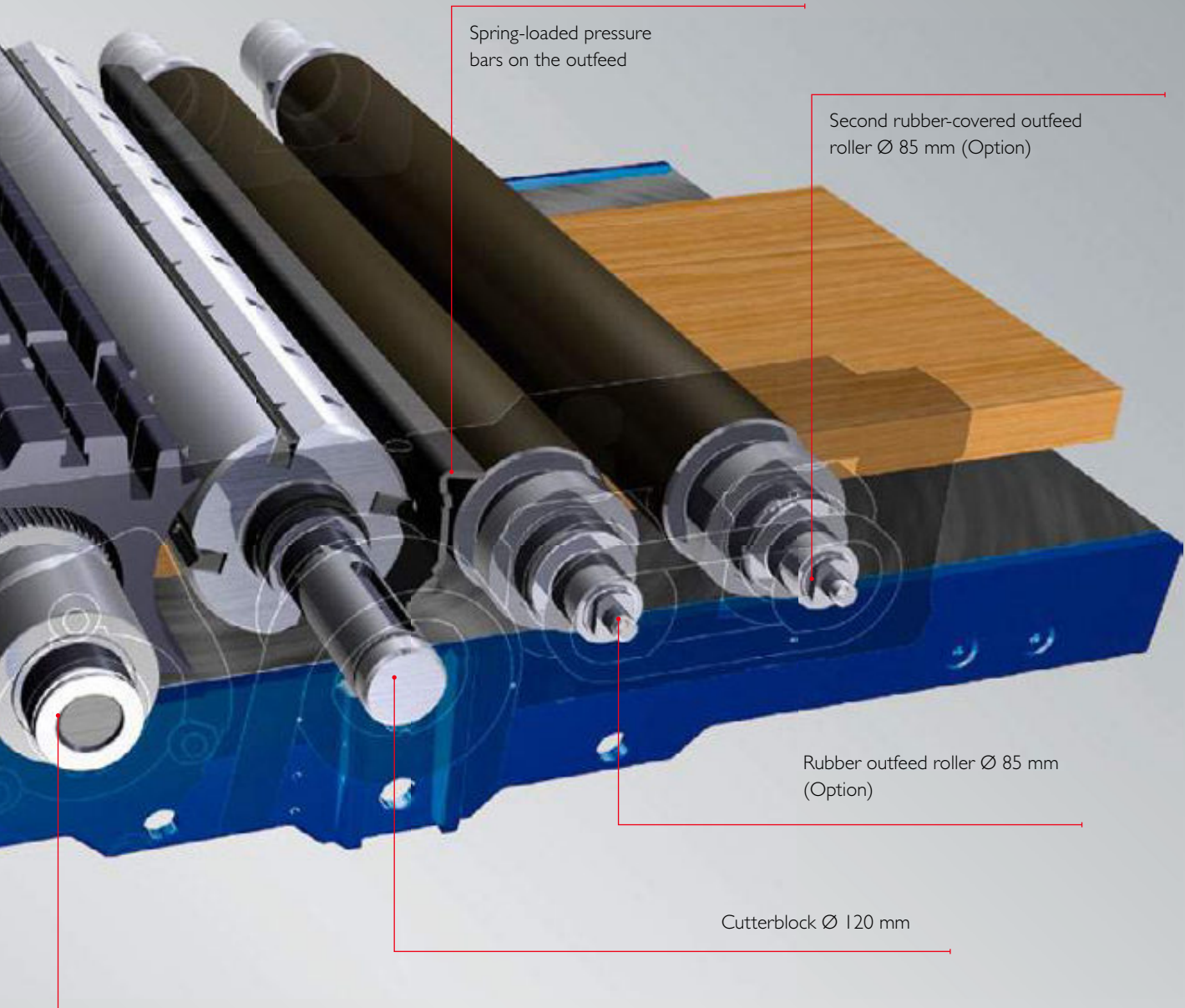

Infeed rollers

The infeed rollers are suspended in place, ensuring that they lift gently when working with a large depth of cut. There are 3 different types of infeed rollers to choose from:

- The spiral micro-toothed infeed roller guarantees that there is a constant feed of the workpiece, not allowing it to slip.
- The rubber coated infeed roller is ideal for thin workpieces or when working with a shallow depth of cut. Workpieces with slight difference in height can be processed simultaneously.
- The segmented steel roller is capable of simultaneously processing a number of workpieces all varying in size. The spiral tooth design ensures a constant feed of the workpiece and is practically wear and tear free.

The infeed pressure bar is segmented. Each segment is spring loaded and can move independently of the others. This guarantees an optimum pressure on the workpiece regardless of the dimension.

Outfeed rollers

An outfeed roller ensures that the workpiece is transported out of the machine smoothly.

For processing predominantly wide pieces of wood there is the option of having a second outfeed roller fitted. A second outfeed roller is of particular benefit when processing long workpieces or problematic material with a high frictional resistance and even if no lubrication solution is used, the result is significantly improved. For a perfect surface finish, we recommend rubber outfeed transport rollers.

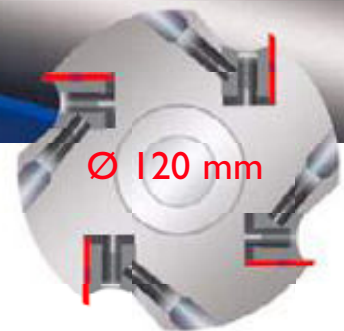

Cutterblock options

Four different knife systems to choose between:

→ 4-knife System cutterblock - Planer knife adjustment without tools – standard with your Format-4!

- 4 knife cutterblock
- Quick and effortless knife change
- Self aligning knives are perfectly set each and every time
- No resin buildup on the clamping bolts.
- Extremely quiet operation due to the enclosed design
- Excellent durability of knife edges
- Cost savings due to the 2 sided low cost knives

→ 4 knife TERSA-system cutterblock

→ 4-knife Standard cutterblock



Revolutionary: Silent-POWER® cutterblock

Sensationally quiet planing and money saving!

Exclusive for planing machines from the Felder Group

The Silent-POWER® Spiral cutterblock reduces noise emissions by more than half when planing. The continuous pulling cut ensures tear-free results when planing all types of wood. With this revolutionary new development from Felder you are obtaining all of the advantages of a spiral cutterblock at considerably lower operating, investment and adjustment costs.

The advantages of the Silent-POWER® cutterblock at a glance ...

- Sensationally quiet, noise emissions halved
- Blade life up to 20 times longer
- Four highly precise cutting edges on each knife
- Optimised chip extraction and reduced chip volume
- Tear free planing results
- Reduced power consumption when compared to similar systems



Smaller chips - compact better

The optimised extraction hood ensures that the noticeably shorter chips are effectively extracted and land considerably more compact in the dust bags.

Control system exact 63 + exact 51



... with "Power-Drive"
it is all electric

Turn the control knob for quick adjustment, and push the button for fine adjustment. The LED display clearly shows the actual value.



... with "Digi-Drive"
simply type it in

Enter the required dimension, press Start and the thicknesser table will move precisely to the required position. Set and actual values are displayed on LED displays. Additional optional functions, such as incremental position and four programmable thicknesser table positions are available.



Feed rate

Standard: Variable feed speed of between 5–20 m/min.
Whether its a perfect finish or quick thickness calibration that is required, the correct feed speed can always be set to match.

Details that impress!

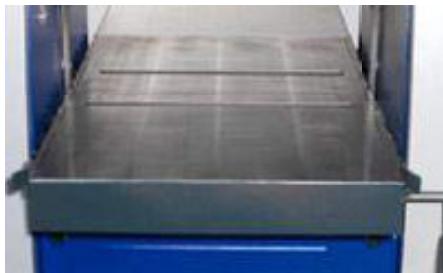
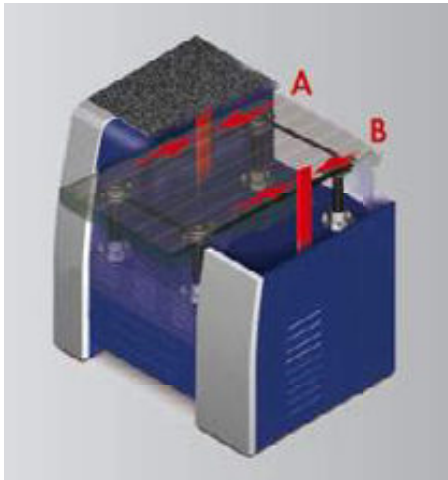

Optional integrated adjustable rollers are available for processing workpieces with high resin or moisture content.

Outstanding stability and long-lasting precision

4 trapezoidal spindles guarantee exact adjustment precision and ensure maximum thickening bed load. Longitudinal guides integrated into the side of the machine chassis absorb the pressure that is put on the outfeed side and ensure that the thickening table is guided with an accuracy of a tenth of a millimetre.



For those customers that regularly process wet or resinous wood, we would recommend the option of the workpiece roller and lubrication unit on the infeed side of the machine.

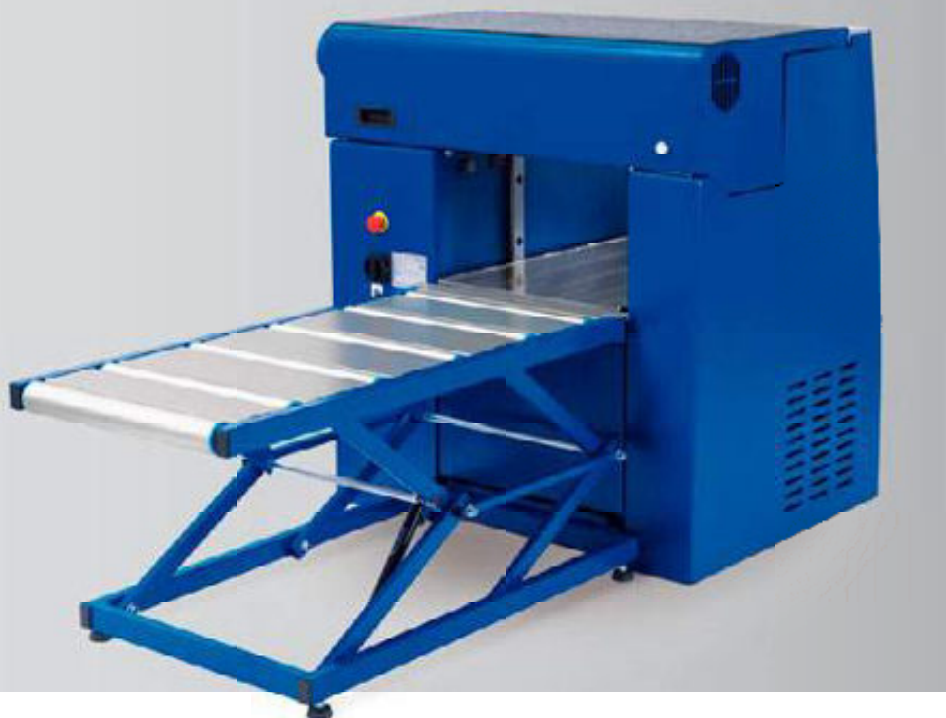

Height-adjustable scissor table

For especially large and heavy workpieces there is a scissor lifting table with a length of 1150 mm available. The scissor lifting table moves together with the thickening table.

Technical specifications



| | exact 51 | exact 63 |
|--|----------------------------------|----------------------------------|
| Maximum depth of cut | 10 mm | 10 mm |
| Thicknessing width | 504 mm | 630 mm |
| Thicknessing height min.-max. | 3–300 mm | 3–300 mm |
| 5.5 HP (4,0 kW) | S | - |
| 7.5 HP (5,5 kW) | O | S |
| 10.0 HP (7,35 kW) | O | O |
| 15.0 HP (11,0 kW) | - | O |
| Height (closed) | 1170 mm | 1193 mm |
| Height (open) | 1900 mm | 1950 mm |
| Length [L] | 1113 mm | 1226 mm |
| Width [W] | 1000mm | 1262 mm |
| Extraction connection-Ø Thicknesser | 140 mm | 160 mm |
| Acoustic noise level [dB (A)] in accordance with EN ISO 3746 when switched on but not running*** | 83 ² | 86 ² |
| Acoustic noise level [dB (A)] in accordance with EN ISO 3746 when running*** | 95 ² | 91 ² |
| Acoustic noise level at the workstation [dB (A)] in accordance with EN ISO 11202 when switched on but not running*** | 73 ² /68 ³ | 70 ² /70 ³ |
| Acoustic noise level at the workstation [dB (A)] in accordance with EN ISO 11202 when running*** | 87 ² /84 ³ | 76 ² /71 ³ |

***An allowance must be made to compensate for tolerances with the specified emission values. K= 4 dB (A);

S ... Standard equipment O ... Option - ... Not available;

² ... Thicknesser Working position 1 ³ ... Thicknesser Working position 2 ^{2,3} ... measured using the Silent-POWER® spiral cutterblock



Further information about the technical data, individual configuration options and all noise level values can be found on the internet at www.format-4.com

Space requirement

Scale

1:50

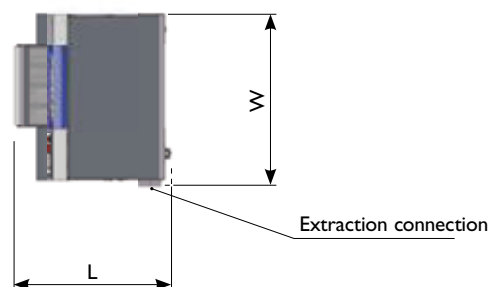

Actual machine may differ from symbolic image exact 51, exact 63

Dimensions given can vary if special equipment is used

dual 5 l

Absolute precision at the touch of a button

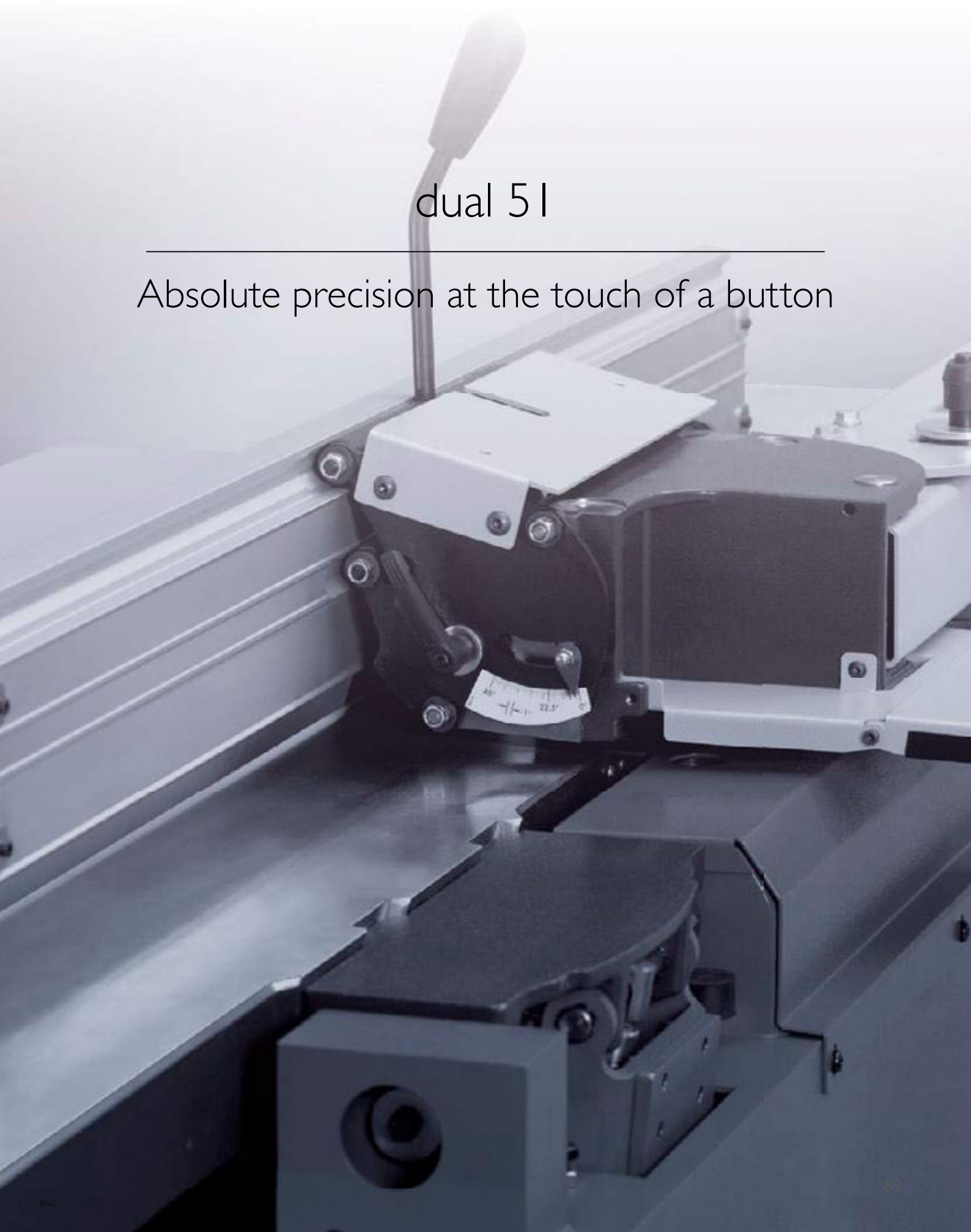



dual 51

A powerful combination, the surface planer thicknesser combination for highly demanding tasks

The clearly laid out machine design purveys at first glance the main highlights of the planer/thicknesser range from Format-4: Stability, reliability and operating comfort of the highest level. The intuitive Format-4 operating concept offers maximum comfort and efficiency. Changing from planing to thicknessing on the dual 51 requires just a couple of hand movements and as an option is also possible at the touch of a button, offering the quickest changeover system in its class.



- Surface planing width 510 mm
- Surface planer table length 2250 mm
- Variable speed 4–16 m/min
- Cutterblock diameter 120 mm
- 4 knife system cutterblock as standard, optional 4 knife-standard blade cutterblock or Silent-POWER® spiral cutterblock
- Electrical height adjustment of the thicknesser table
- Position control



The machine illustrations may show optional equipment. Please refer to your individual quote for clarification on which options are included.

The most important highlights at a glance

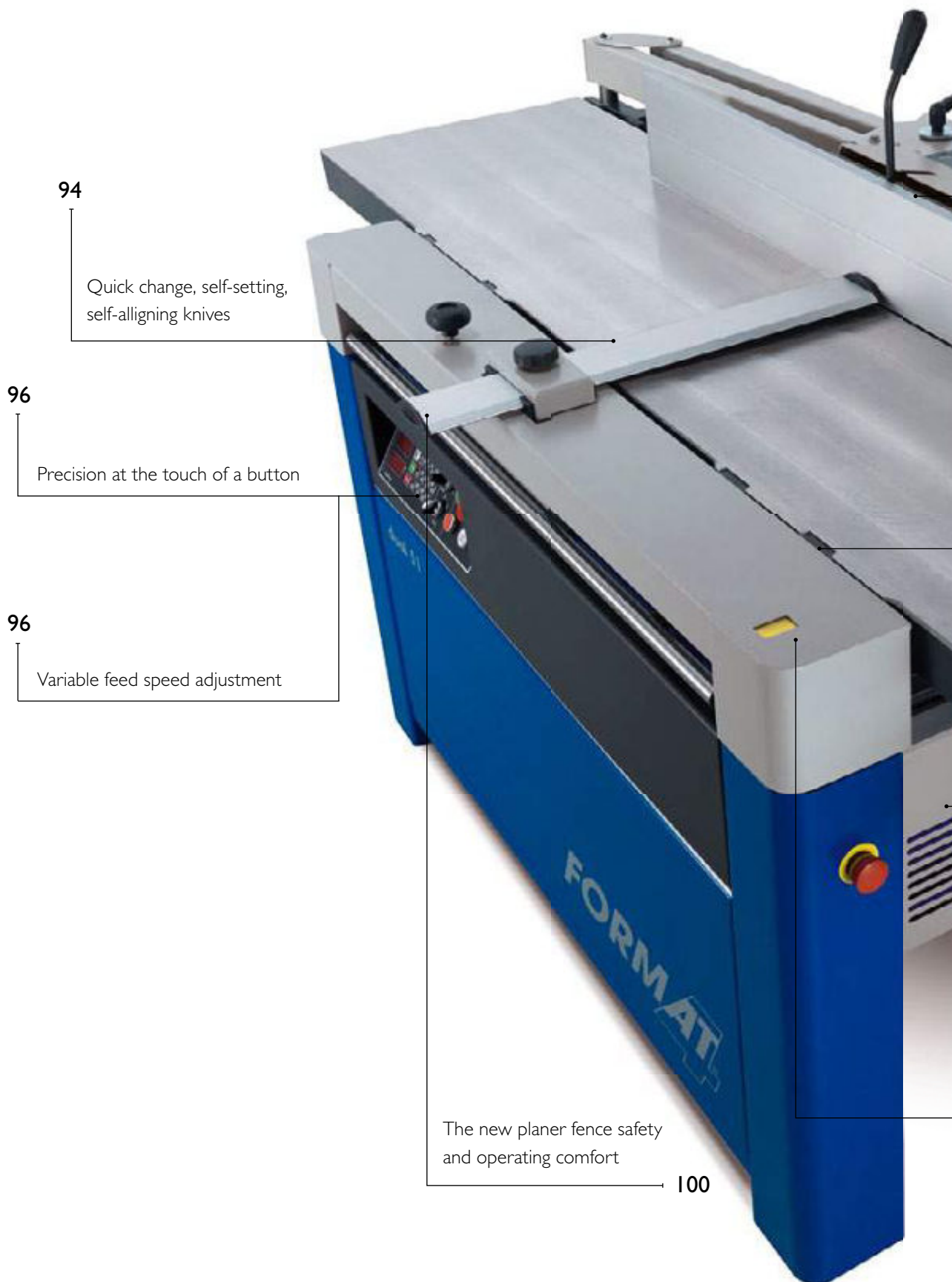

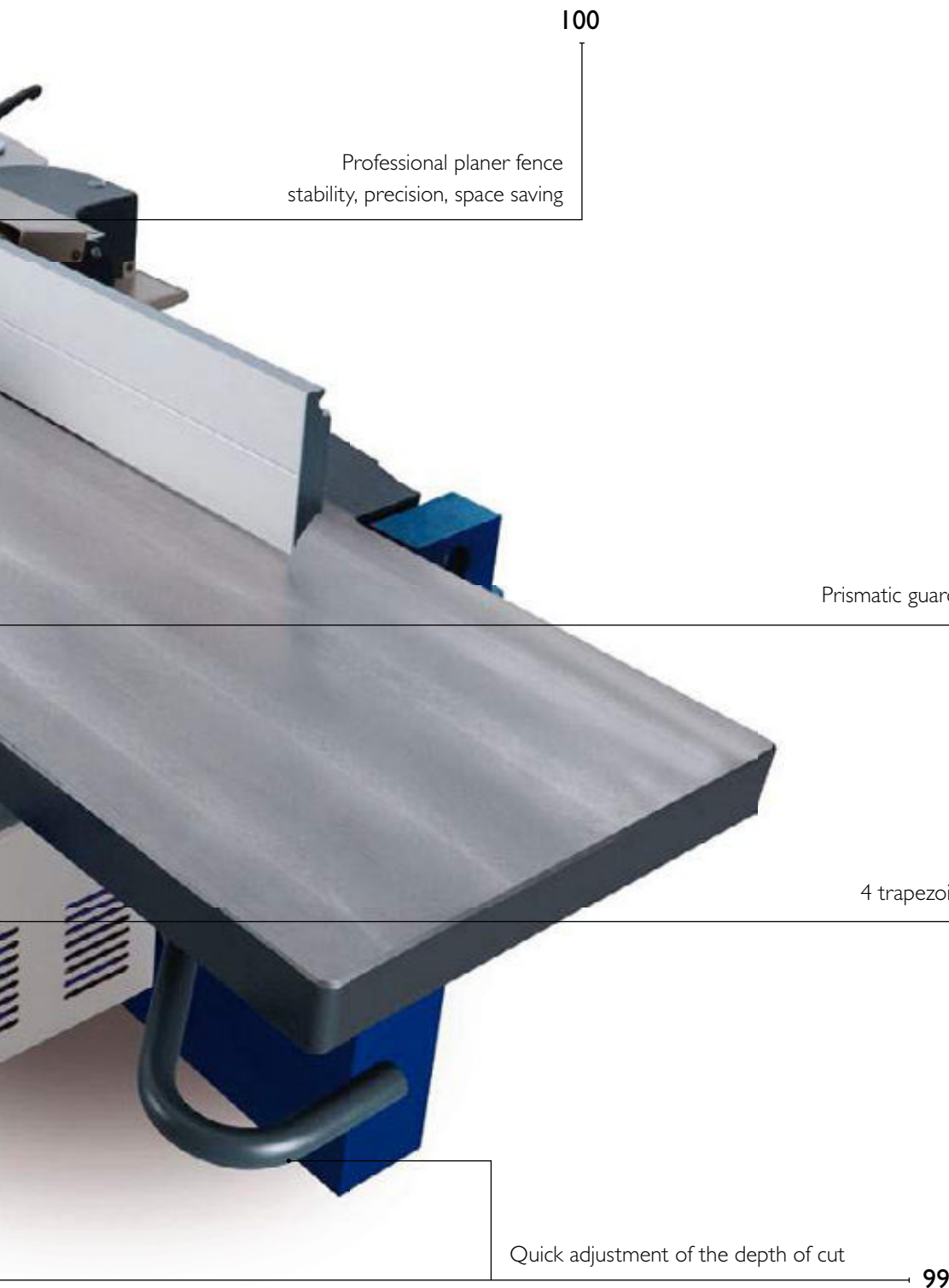

100

Professional planer fence
stability, precision, space saving

99

Prismatic guarding system

97

4 trapezoidal spindles

Quick adjustment of the depth of cut

99

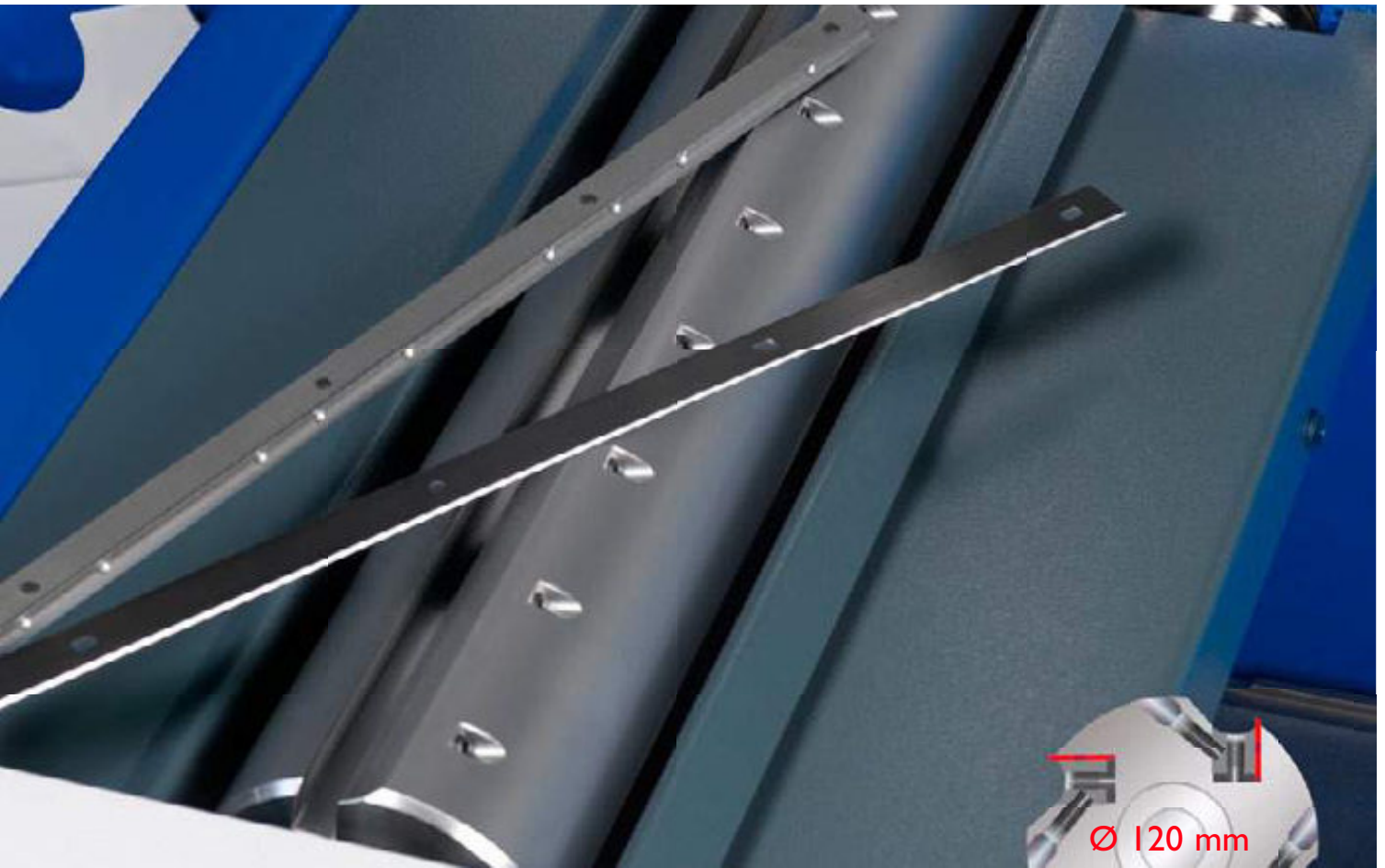

4 knife cutterblock

See and feel the sensational planing results!

For decades the Format-4 system with double sided disposable planer knives proved its advantages. Perfectly manufactured and adjusted in the factory, there is no need to adjust the planer knives, and no expensive adjusting tools have to be purchased.

It's simple to change the planer knives. In less than a few minutes you can change either the 4 knife cutterblock. Format-4 planer knives are set and ready to use! With a 120 mm diameter, 4 knife Format-4 quick change self aligning cutterblock, Format-4 have taken planing to a new dimension. As an option you can also equip your Format-4 with a Silent-POWER® spiral cutterblock, or with Standard or Tersa knife systems.

Planer knife adjustment without tools – standard with your FORMAT-4!

- 4-knife cutterblock
- Quick and effortless knife change
- Self aligning knives are perfectly set each and every time
- No resin buildup on the clamping bolts
- Extremely quiet operation due to the enclosed design
- Excellent durability of knife edges
- Cost savings due to the 2 sided low cost knives



Revolutionary: Silent-POWER® cutterblock

Sensationally quiet planing and money saving!

Exclusive for planing machines from the Felder Group

The Silent-POWER® Spiral cutterblock reduces noise emissions by more than half when planing. The continuous pulling cut ensures tear-free results when planing all types of wood. With this revolutionary new development from Felder you are obtaining all of the advantages of a spiral cutterblock at considerably lower operating, investment and adjustment costs.

The advantages of the Silent-POWER® cutterblock at a glance ...

- Sensationally quiet, noise emissions halved
- Blade life up to 20 times longer
- Four highly precise cutting edges on each knife
- Optimised chip extraction and reduced chip volume
- Tear free planing results
- Reduced power consumption when compared to similar systems



Smaller chips - compact better

The optimised extraction hood ensures that the noticeably shorter chips are effectively extracted and land considerably more compact in the dust bags.

Control dual 5 I



... with "Power-Drive"
it is all electric

Turn the control knob for quick adjustment, and push the button for fine adjustment. The LED display clearly shows the actual value.



... with "Digi-Drive" simply type it in

Enter the required dimension, press Start and the thicknesser table will move precisely to the required position. Set and actual values are displayed on LED displays. Additional optional functions, such as incremental position and four programmable thicknesser table positions are available.

Individual feed speeds

Regardless of the type of wood and grain, the variable feed speed of between 4–16m/min always guarantees a perfect thicknessing result.

Details that impress!

4 trapezoidal spindles guarantee exact adjustment precision and ensure maximum thickening bed load. Longitudinal guides integrated into the side of the machine chassis absorb the pressure that is put on the outfeed side and ensure that the thickening table is guided with an accuracy of a tenth of a millimetre. Optional integrated adjustable rollers are available for processing workpieces with high resin or moisture content.

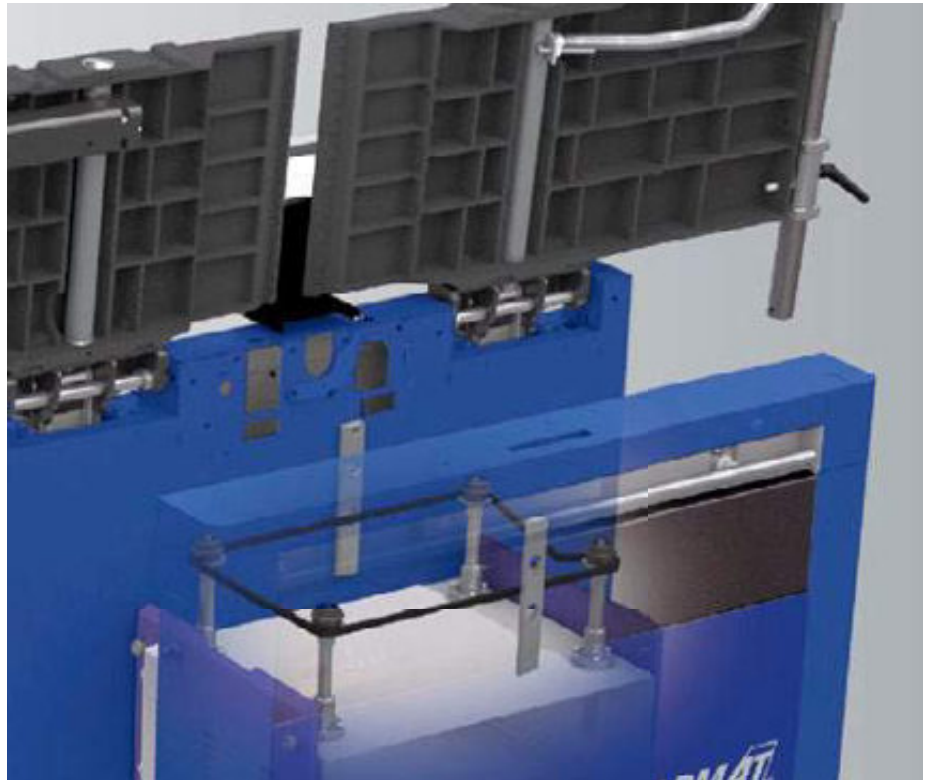

Dust extraction hood. Heavy chip loads and moist wood are no problem for the chip extraction hood due to its efficient design and large dimension.



2 spring-loaded pressure bars prevent "fluttering" of very thin workpieces whilst thickening.



The optional rubber infeed and outfeed transport rollers are the perfect solution when working with difficult, tearout prone, very thin or different thickness workpieces and those jobs requiring minimal final thickness. On request, we can provide a spring-loaded, segmented infeed pressure bar, combined with infeed rubber roller for simultaneous processing of timber of varying thickness.



Intuitive, synchronised opening of the dual planing table

The tried and tested Format-4 operating concept reduces the effort in changing from planing to thicknessing to a minimum. The intuitive table clamping system makes it possible to synchronously lock and open the planing tables with a twist of the hand, industrial springs assist in the opening.



The new electric automatic changeover

That is first class operating comfort. At the touch of a button you can open and close the planing table when changing from planing to thicknessing and vice versa.





Patented planer adjustment system

Accurate adjustment is obtained with Felder's patented planer adjustment system, which incorporates lateral prismatic guide rails.



Quick and accurate adjustment of cutting depth from the operator side of the infeed table.

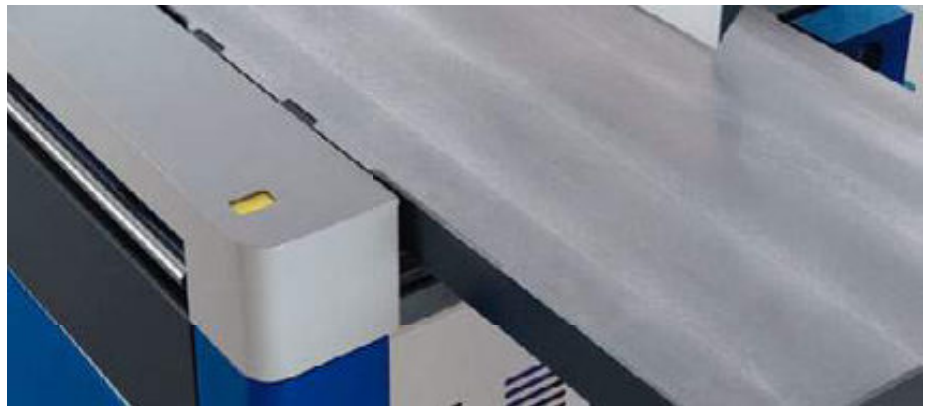

The depth of cut can be set to any depth up to 8 mm. Using the integrated magnifying glass you can view the set depth and achieve the exact results that you are looking for.

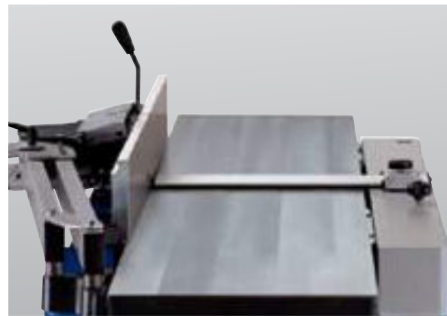

The planer fence: A masterpiece of engineering providing stability, precision and performance!

The planing fence can be tilted to any angle between 90° and 45°. There are positive stops at 90° and 45°. The exceptional space-saving design of the planer fence makes it possible to place your planer-thicknesser directly against the workshop wall and still use the entire planing width.

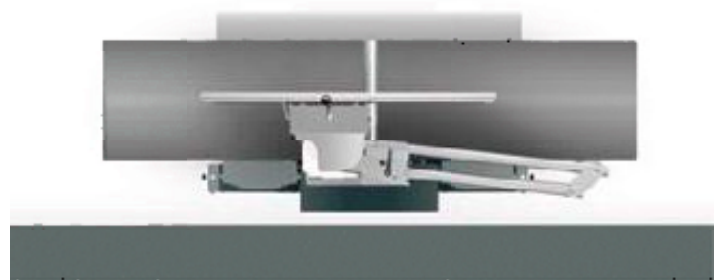



The FORMAT-4 planer guard

Maximum operational safety and an unprecedented ease of use. The space saving planer guard integrated into the machine chassis also stabilises the workpiece when planing and bevelling the narrow edge.

Comfort planer guard

Folds in two places. This ensures that it does not restrict you whilst planing.



Aigner combination fence

The auxiliary fence is built into the planer fence ensuring that it does not get in the way when the fence is at an angle.

Technical specifications



| | dual 51 |
|--|---|
| Planer table length | 2250 mm |
| Maximum depth of cut Planer/Thicknesser | 8/8 mm |
| Surface planing width | 510 mm |
| Thicknessing width | 504 mm |
| Thicknessing height min.-max. | 3–254 mm |
| 5.5 HP (4.0 kW) | S |
| 7.5 HP (5.5 kW) | O |
| 10.0 HP (7.35 kW) | O |
| Height (closed) | 1270 mm |
| Height (open) | 1650 mm |
| Working height | 890 mm |
| Length [L] | 2252 mm |
| Width [W] | 965–1642 mm |
| Extraction connection-Ø surface planer/Thicknesser | 140 mm |
| Acoustic noise level [dB (A)] in accordance with EN ISO 3746 when switched on but not running*** | 85 ¹ /83 ² |
| Acoustic noise level [dB (A)] in accordance with EN ISO 3746 when running*** | 92 ¹ /91 ² |
| Acoustic noise level at the workstation [dB (A)] in accordance with EN ISO 11202 when switched on but not running*** | 73 ¹ /71 ² /72 ³ |
| Acoustic noise level at the workstation [dB (A)] in accordance with EN ISO 11202 when running*** | 82 ¹ /76 ² /77 ³ |

***An allowance must be made to compensate for tolerances with the specified emission values. K= 4 dB (A);

S ... Standard equipment O ... Option - ... Not available;

¹ ... Planer ² ... Thicknesser Working position 1 ³ ... Thicknesser Working position 2 ¹²³ ... measured using the Silent-POWER® spiral cutterblock



Further information about the technical data, individual configuration options and all noise level values can be found on the internet at www.format-4.com

Space requirement

Scale

1:50

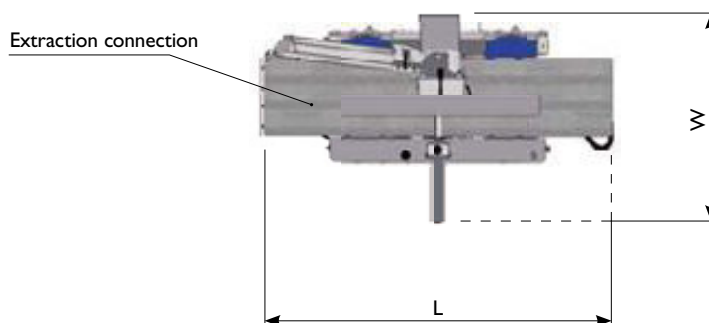

Actual machine may differ from symbolic image dual 51

Dimensions given can vary if special equipment is used

profil 45 Z
profil 45 M

Power package with premium comfort

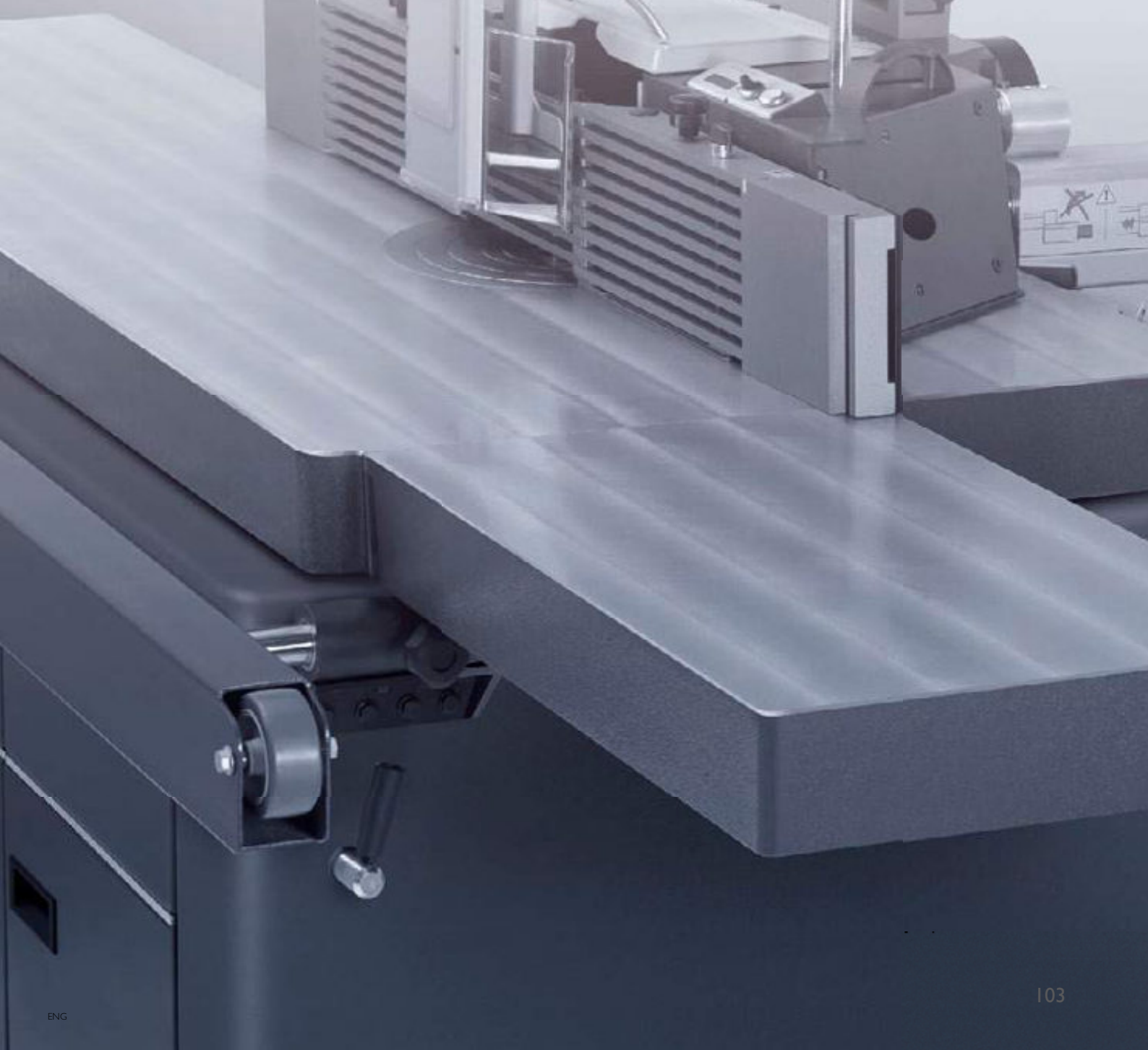



profil 45 Z profil 45 Z x-motion

Moulding comfort of another class

Elegant, perfectly designed and intelligent - the Format-4 profil 45 Z offers perfection at the push of a button regardless of the operation. The highlights for the professional user: height and angle adjustment of the spindle as well as the positioning of the spindle fence can be quickly and easily adjusted from the control panel. The spindle quick change system ensures extremely quick changeover times and maximum production efficiency. Premium woodworking of the highest level with quality from Austria.



- Electrical height adjustment for the moulding spindle
- Electric moulder spindle angle adjustment
- Electric spindle moulder fence setting
- LED display on the control panel
- LED display on moulder fence
- Sawdust extractor below the table
- Opening of moulder table 320 mm
- Quick-change system for moulder spindle
- Slotting and tenoning table and many other details





profil 45 M profil 45 M x-motion

The powerhouse with premium comfort

The new tilting spindle moulder with fixed bed from Format-4 offers top quality Austrian machine construction precision combined with elegant design, premium operating comfort and innovative high tech solutions. Stability and high performance even when run at its limits. The solid, highly precise cast iron bed guarantees maximum stability and vibration free processing. The 7" TFT monitor included in the "x-motion" control package offers unique user comfort that is simply top class. The touch screen control unit is positioned at eye level and provides all of the important information necessary in one overview.



- Electrical height adjustment for the moulding spindle
- Electric moulder spindle angle adjustment
- Electric spindle moulder fence setting
- LED display on the control panel
- LED display on moulder fence
- Sawdust extractor below the table
- Opening of moulder table 320 mm
- Quick-change system for moulder spindle
- Solid cast iron table for vibration-free stability



The most important highlights at a glance



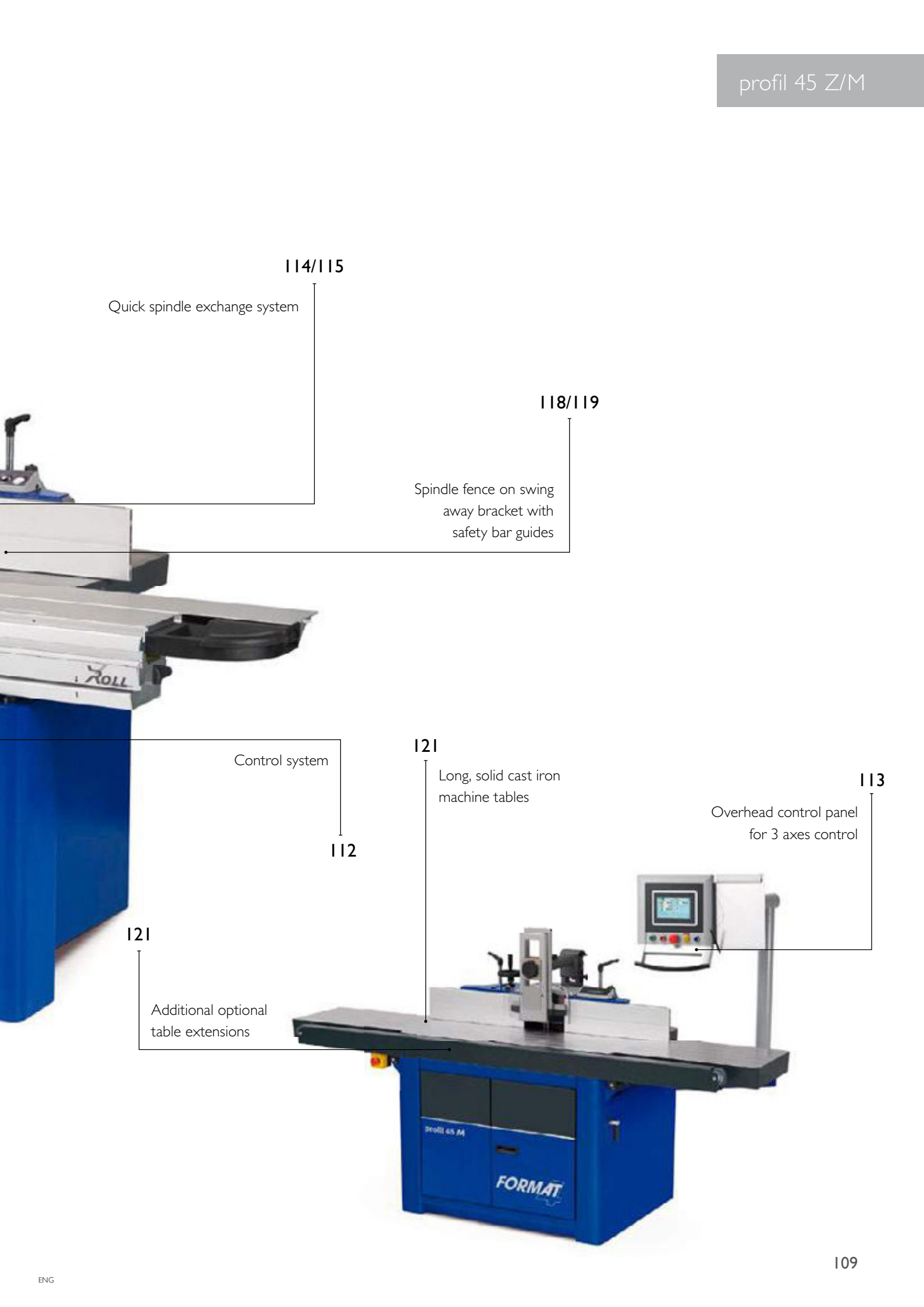

114/115

Quick spindle exchange system

118/119

Spindle fence on swing away bracket with safety bar guides

Control system

112

121

Long, solid cast iron machine tables

113

Overhead control panel for 3 axes control

121

Additional optional table extensions

The spindle moulder unit

The Spindle Unit: Precision, down to the smallest detail

Every detail of the heavy duty profil 45 spindle moulder unit has been designed based on decades of machine manufacturing experience combined with modern production techniques.

The powerful spindle motor unit on the profil 45 has been specially designed for industrial use. With the precision dual guidance ensuring exact angle adjustments and the dovetail guiding system guaranteeing exact linear height adjustment, you are assured accurate settings for many years to come.

- Spindle operating height of up to 140 mm
(160 for 40 and 50 mm diameter spindles)
- Table opening 320 mm
- Quick-change spindle system
- Change of speed from front of machine
- High speed router spindle (15.000 rpm) (Option)
- Electronic height adjustment with LED display
- Electronic angle adjustment with digital LED display
- Rearward tilt 0° to 45° (-5° to 45° with "Digi-Drive")
- Dovetail guidance system of the height adjustment
- Maximum energy transfer from the large Poly-V belt bearing area
- 3 bearing seats for spindle
- Excellent vibration absorption from heavy cast iron unit
- **6 Year Guarantee** on "Easy-Glide" Format-4 tilting segment
 - High durability
 - Play-free tilt
 - Unaffected by dust
 - Completely maintenance free
 - No lubrication required



Tilt segment "Easy-Glide"



6

YEAR GUARANTEE
on "Easy-Glide"
Format-4
tilting segment

The Spindle Unit with Precision Double Suspension – the tilting segments are made out of solid cast iron. The forced guiding system ensures precision and repeatable accuracy of settings.

Maximum energy transfer from the Poly-V belt



Control system

The "Power-Drive" package offers maximum user-friendliness ensuring that the height and angle adjustment of the spindle moulder can be quickly and precisely electronically controlled. The turn of a knob adjusts the quick settings and the fine adjustment is carried out at the push of a separate button. Red LED digits display the actual value in real time on the control panel.



Spindle fence control

The precise quick adjustment of the spindle (depending on the machine configuration either directly on the spindle fence or from the optional overhead touch screen) is done using motors and the current setting is displayed in real time.



“x-motion” control

Top class operating comfort

One of the absolute highlights of the new profil 45 M is the 7" TFT monitor with “x-motion” control package for unique user comfort of the premium class. The touch screen control unit is always at eye level and provides all the important information at a glance. Alongside all of the settings of the spindle, the new Format-4 spindle moulder fence can also be controlled directly from the touch screen. The premium package offers maximum efficiency, with program recall at the touch of a button with individual configurable moulding programs and an optionally available tooling database.

- 7" TFT colour monitor built into the overhead panel
- Touch screen control
- The spindle moulder fence can be positioned precisely
- Spindle height and angle control at the touch of a button
- Specific configurable moulding programs
- Individual user administration
- Optional tooling database
- Quick referencing of the spindle height and angle after changing the tool
- Correction of the spindle height and fence following an adjustment of the angle
- Changing between absolute and incremental values

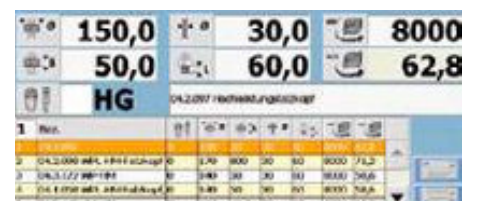
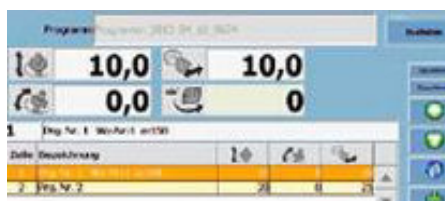
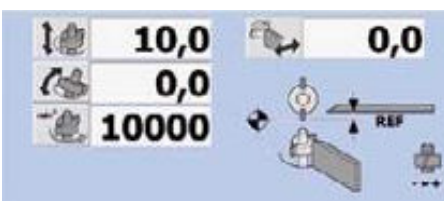
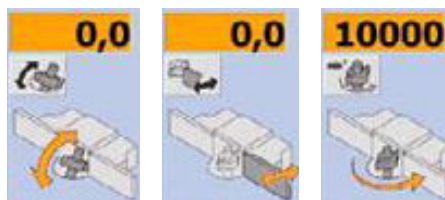



Spindle moulder

Quick-change of moulder spindle

The spindle quick-change system will provide you with almost limitless possibilities of use. You can use spindles with pre-mounted tools for series production, or use spindles with a different diameter. The spindle can be changed in seconds. A particular highlight is the ability to mount a high speed router spindle with 15.000 rpm capability. For maximum stability and durability the Format-4 spindle has been designed with 3 high quality "precision type" bearings!

Quick change system for the spindle moulder with the following advantages:

- Quick, easy change between different types of spindles
- Ability to use 30, 32, 35, 40, 50 mm and 1¼" diameter spindles
- High speed Format-4 router spindle for router bits with 15.000 rpm
- Automatic repeatable setting for series production work



Save valuable production time with the quick change system of the spindle and premium operating ease of use

Take full advantage of the technology available from Format-4 and profit from quick tool changes and settings in series production. The spindle can be changed in seconds and together with the user friendly control system you can ensure maximum efficiency with any type of moulding work.

The "Power-Drive" control included as standard ensures the 0.1 mm accurate quick and fine adjustment of the spindle height and angle. With the premium control system on the profil 45 M x-motion all of the settings can be made quickly and precisely using the central 7" TFT colour touch screen display and the tooling database and unlimited program spaces offer additional operating comfort. It is not only the spindle that can be adjusted, the spindle fence can also be electrically positioned using the touch screen.

With machine technology from Format-4 you will always be one step ahead of the competition.

The high speed router spindle is designed for router shaft diameters of \varnothing 6–16 mm and a speed of 15.000 rpm with up to 10 HP.

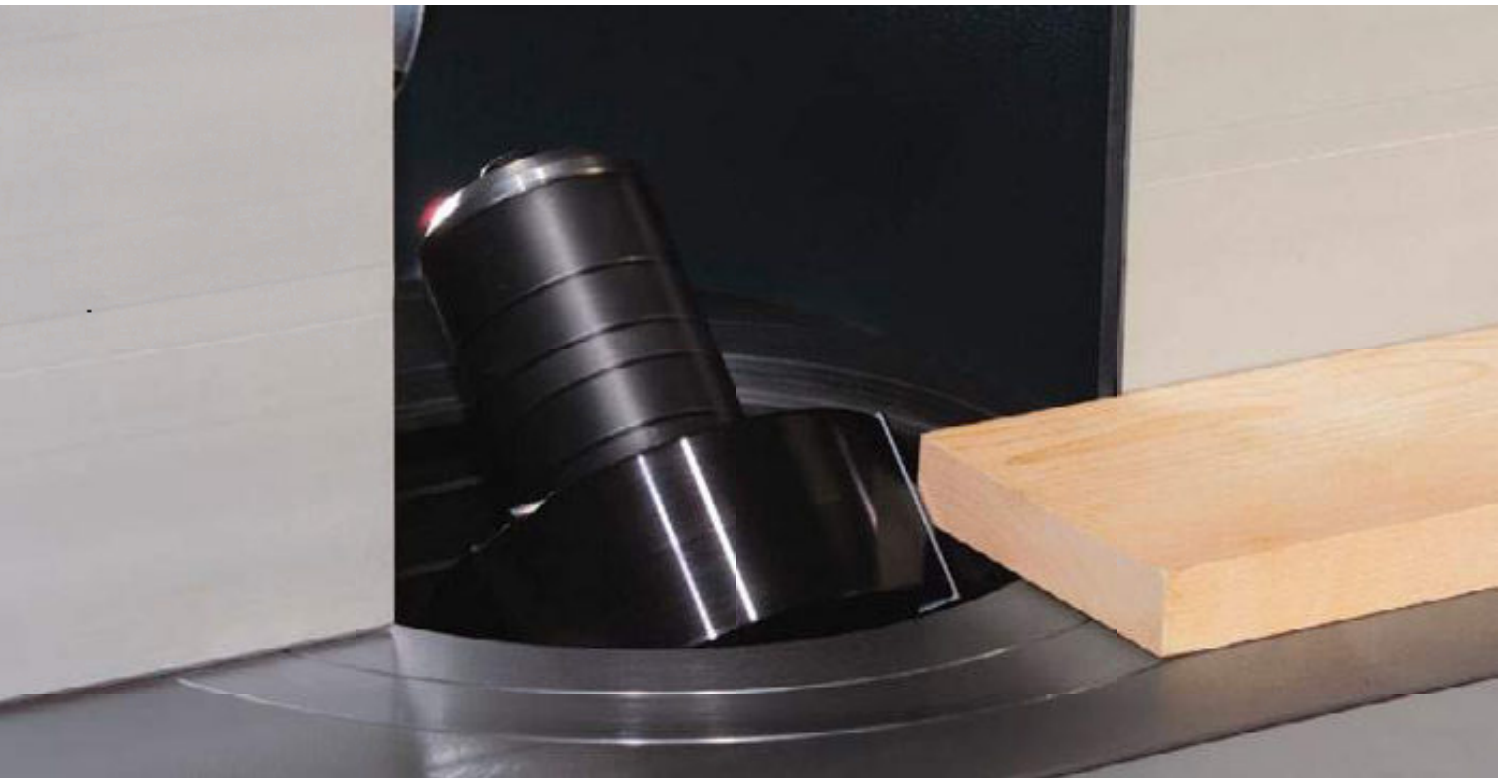

The moulder spindle tilts backwards: a real operating advantage

The FORMAT-4 spindle tilts rearward
which has many advantages:

- Safety, as there is no pinch point
- Suitable for any workpiece size
- Problem-free power feeder application
- Impeccable machined surface
- Optimal chip removal



Forward tilting of the spindle moulder
can be dangerous and has serious
handling disadvantages:

- Increased risk of accidents
- Limited height of workpiece
- Power feeder operation is not possible
- Inferior workpiece finish
- Poor or even impossible chip removal

Spindle moulder fence

Precise adjustments have never been so easy.

Pin point accuracy, exceptional user friendliness, and very short setup time are guaranteed with equipment of the highest standard:

- Convenient electronic spindle fence setting with
- Fine adjustment with one tenth of a millimetre precision.
- LED display for precise reading of measurement and a reset function
- Removable moulder fence guide, adjustable from -10 to +35 mm.
- Tool diameters up to 250 mm
- The complete moulder fence can be tilted away below the moulder table level
- Centrex moulder guard
- Dual dust extraction from moulder fence and beneath the table

Hardened anodised aluminium fence plates standard of the professional range. Accurate fine adjustment on the removable spindle fence via a scale from -10 to +35 mm.

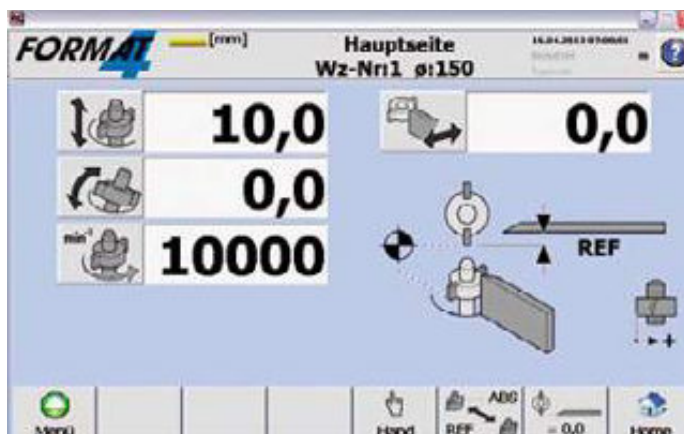

Spindle fence control via touch screen

With the profil 45 M x-motion positioning the fence is done simply and precisely using the centrally located TFT colour display with 7" touch screen. Increase your efficiency and productivity in series production with adjustments being made in seconds and repeatability always guaranteed.



Details that impress

Moulder fence with tilt-away bracket

Important for quick and efficient change of moulding tools, moulder spindle and for curved moulding.

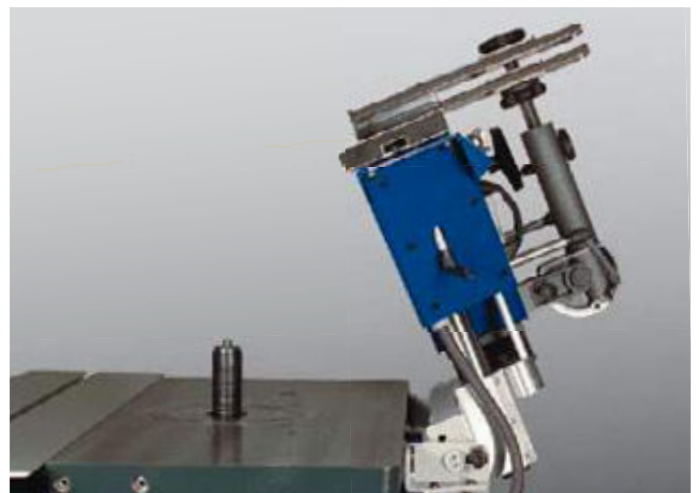
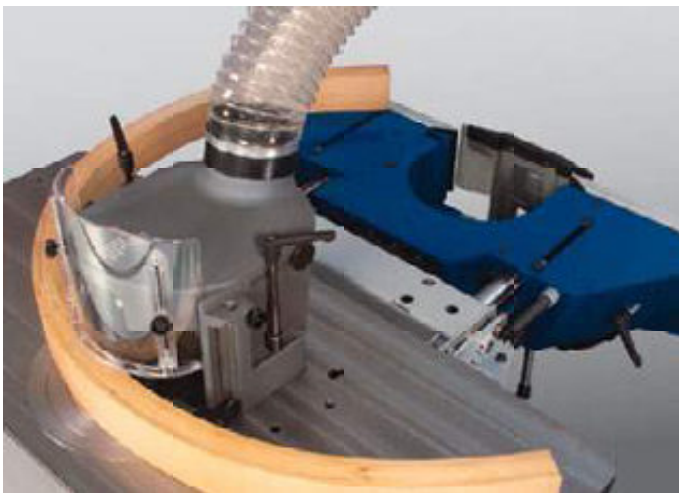
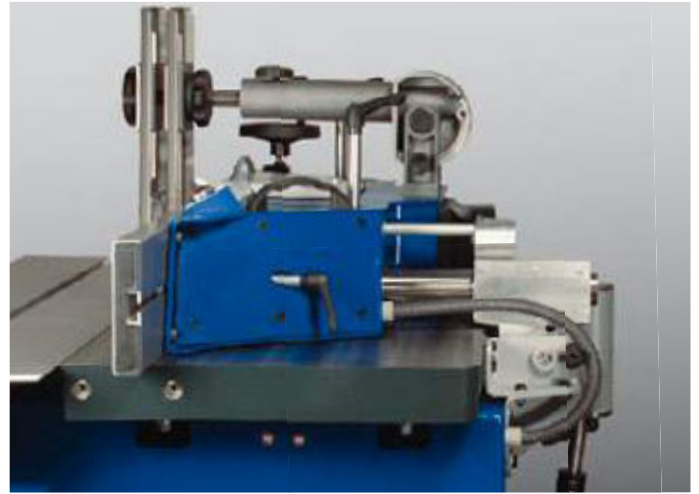

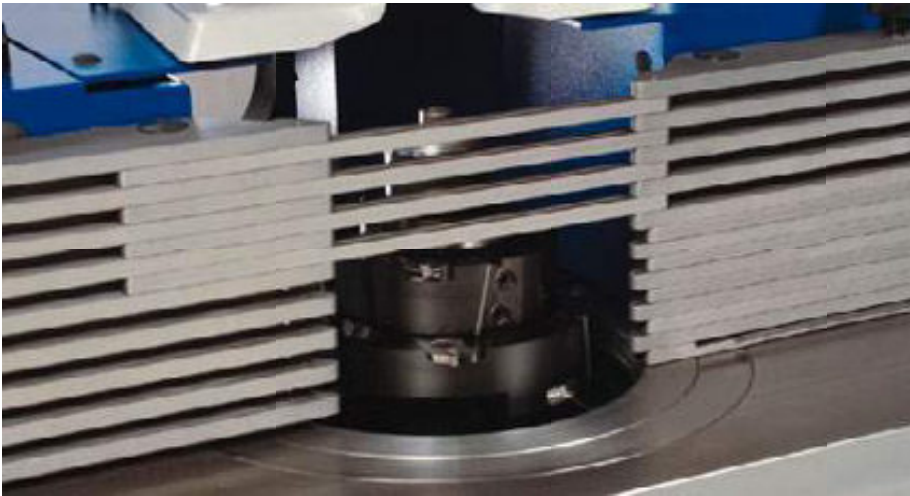

Safety bar guides

The safety bar guides are great for end-grain work (optional).

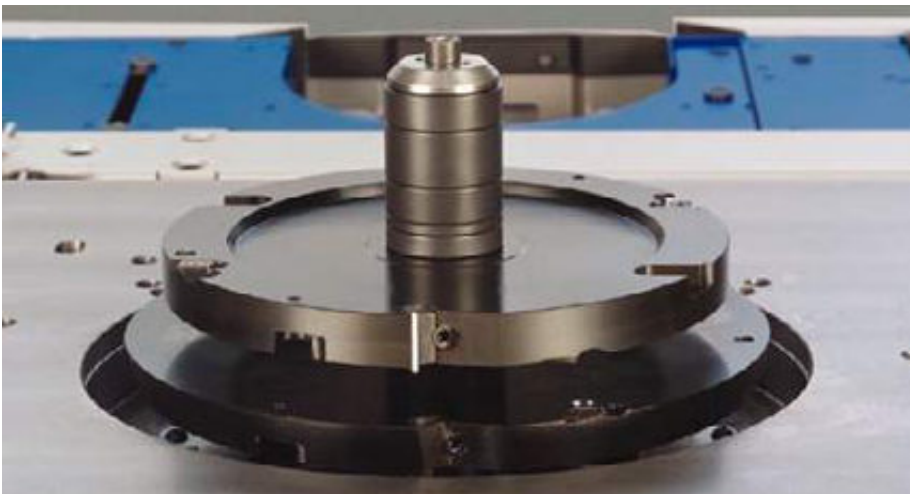

Spindle moulder table opening: 320 mm

The large table opening allows for maximum operator safety. For large dimension tooling, as used for tenoning and panel raising, the cutterblock can be conveniently moved below the table surface.

Spindle extraction

The dual extraction system from the spindle unit and fence ensures that the machine stays clean and dust free.

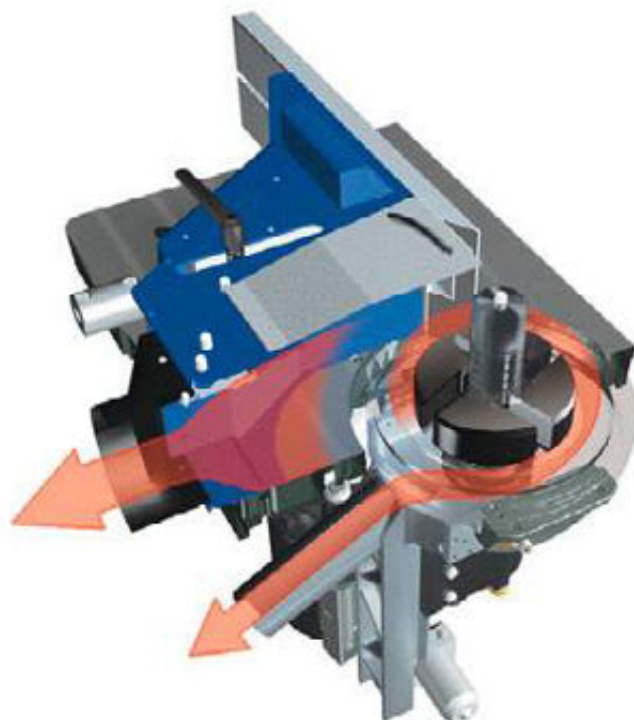



Slot and tenoning

Large and durable, the slot and tenon table "hovers" on top of X-Roll guides - a highly developed, modern guiding design. The shaped arrangement of the rollers ("X-Roll") helps to evenly distribute the pressure on all sides. The linear position of the steel rollers on the hardened and polished guiding surfaces guarantees precision and smooth operation. 10-year factory guarantee.



Outriggers

Simple processing of larger workpieces with the FORMAT-4 outrigger tables.



1100 mm outrigger table

The outrigger table 1100 enables the user to process large, heavy work pieces. Eight rollers guide the telescopic support arm, ensuring precision and stability.



Outrigger table 1300

The 1300 outrigger table has a very large surface area, increasing the support when processing larger pieces. The workpiece roller at the end of the table helps to load larger pieces without causing any damage. When combined with a 2500 mm tenoning table, large doors or windows can be manufactured with ease.



Stability and high performance even when under maximum load

The solid, highly precise cast iron machine table guarantees maximum stability and a complete vibration-free process even when under maximum load.

Additional optional table extensions

The 1270 mm long stable front pull out support increases the support surface by up to 400 mm. The emergency off switch is mounted to the front of the pull out for maximum operating safety and is always within reach.

670 mm table extension with 2200 mm front pull out support

Increase the working surface area of your profil 45 M by 670 mm on both sides with the solid table extensions. If the extensions are taken as an option then the machine will be equipped with an extended front pull out support of 2200 mm.



Specifications



| | | profil 45 Z | profil 45 Z x-motion | profil 45 M | profil 45 M x-motion |
|--|----------|--------------|----------------------|---------------|----------------------|
| Table opening | | 320 mm | 320 mm | 320 mm | 320 mm |
| Tilting of spindle | | 90°-45° | 90°-45° | 90°-45° | 90°-45° |
| Spindle Moulder-Ø 30 mm | | S | S | S | S |
| Speeds 3500/4500/6000/8000/10.000 rpm | | S | S | S | S |
| Variable speed control up to 10,000 rpm | | O | O | O | O |
| High speed router spindle 15,000 rpm | | O | O | O | O |
| 5.5 HP (4,0 kW) | | S | S | S | S |
| 7.5 HP (5,5 kW) | | O | O | O | O |
| 10.0 HP (7,35 kW) | | O | O | O | O |
| Working height | | 890 mm | 890 mm | 890 mm | 890 mm |
| Machine table | | 970 x 442 mm | 970 x 442 mm | 1160 x 770 mm | 1160 x 770 mm |
| Length [L ₁] | | - | - | 1160 mm | 1160 mm |
| Length [L ₂] | | - | - | 2500 mm | 2500 mm |
| Length [L ₃] ** | 1300 mm* | 2872 mm | 2872 mm | - | - |
| | 2050 mm* | 4610 mm | 4610 mm | - | - |
| | 2500 mm* | 5510 mm | 5510 mm | - | - |
| Width [W ₁] | | 1294 mm | 1294 mm | 1172 mm | 1172 mm |
| Width [W ₂] | | 1522/2288 mm | 1522/2288 mm | 323 mm | 323 mm |
| Extraction connection-Ø Spindle moulder fence/below the level of the table | | 140/80 mm | 140/80 mm | 140/80 mm | 140/80 mm |

*Travel distance with outrigger table with max. cutting height.
 **Details of the maximum travelling distance depending on the length of the sliding table.
 S ... Standard features O ... Option - ... Not available E ... Not possible to retrofit



Further information about the technical data, individual configuration options and all noise level values can be found on the internet at www.format-4.com

Space requirement

Scale
 1:50

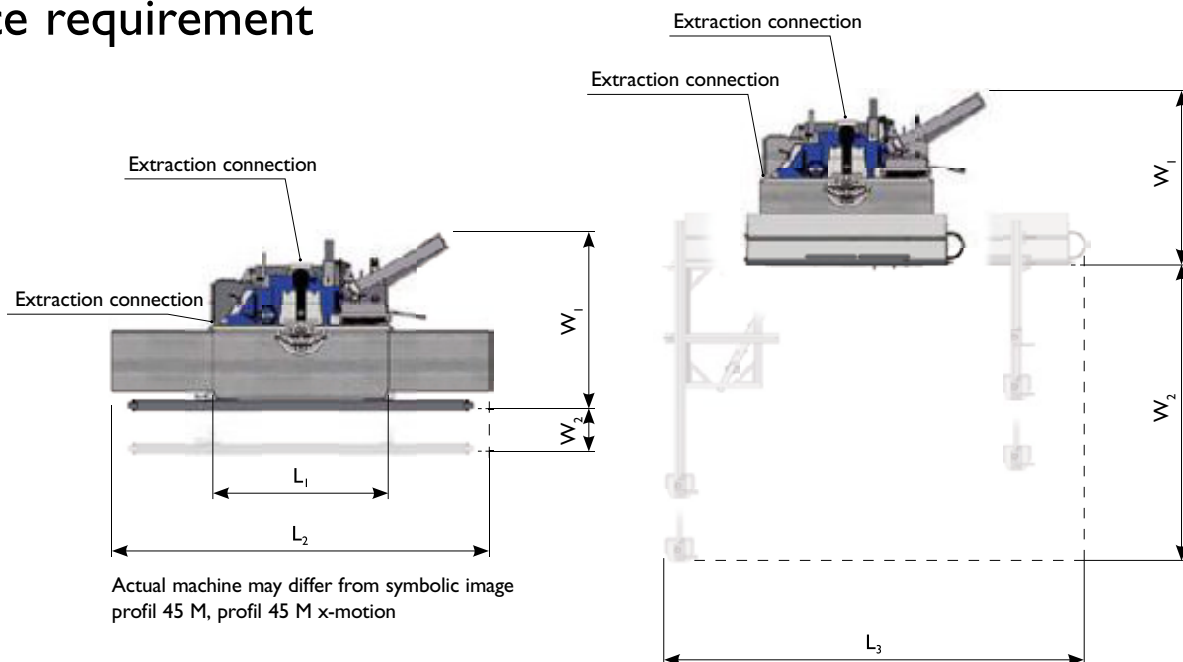

Dimensions given can vary if special equipment is used

Visit us online and see:

- All our machines and key features
- Videos
- Current offers
- Tooling and Accessories
- All technical data



www.format-4.com

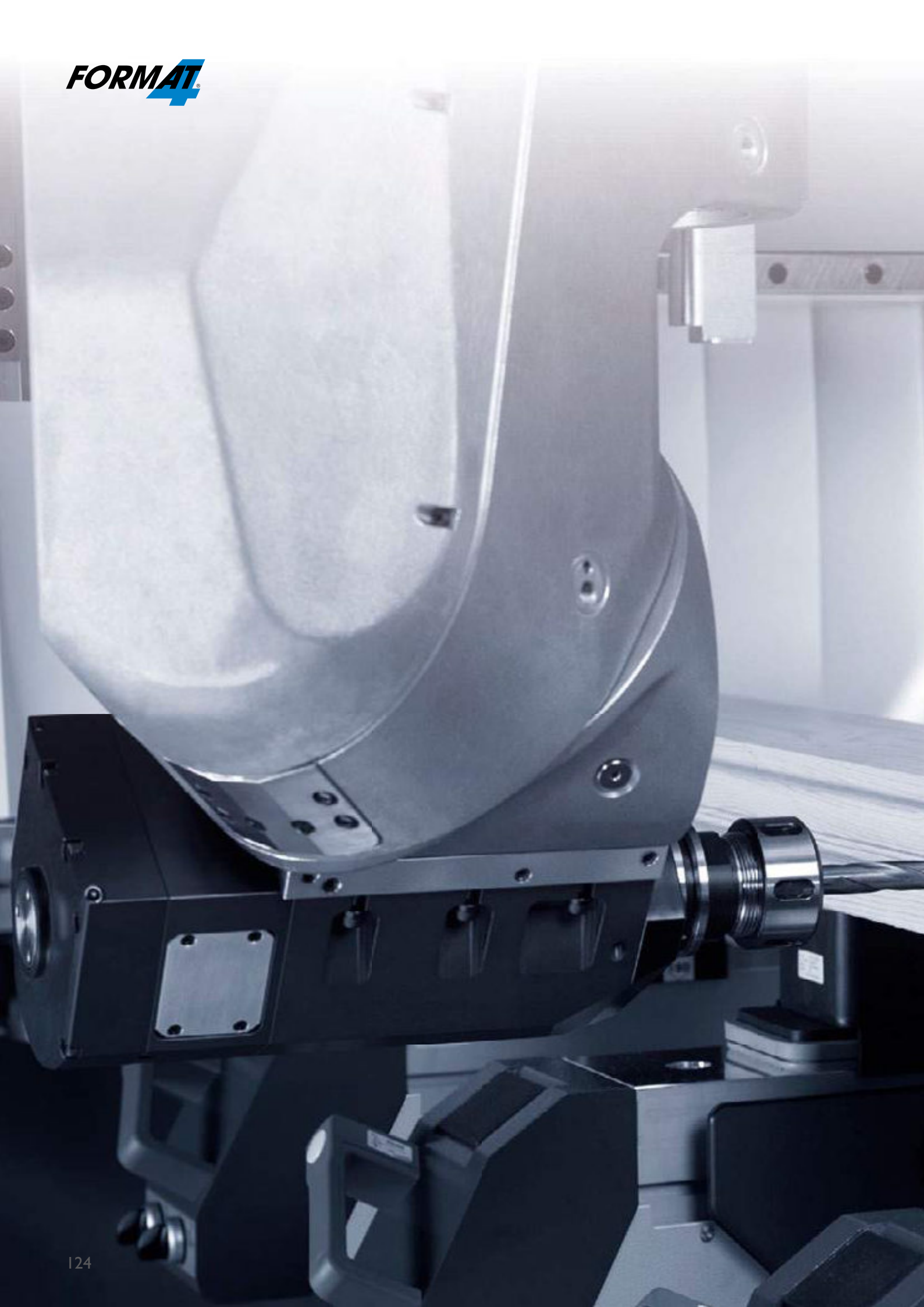

CNC

The revolution in woodworking

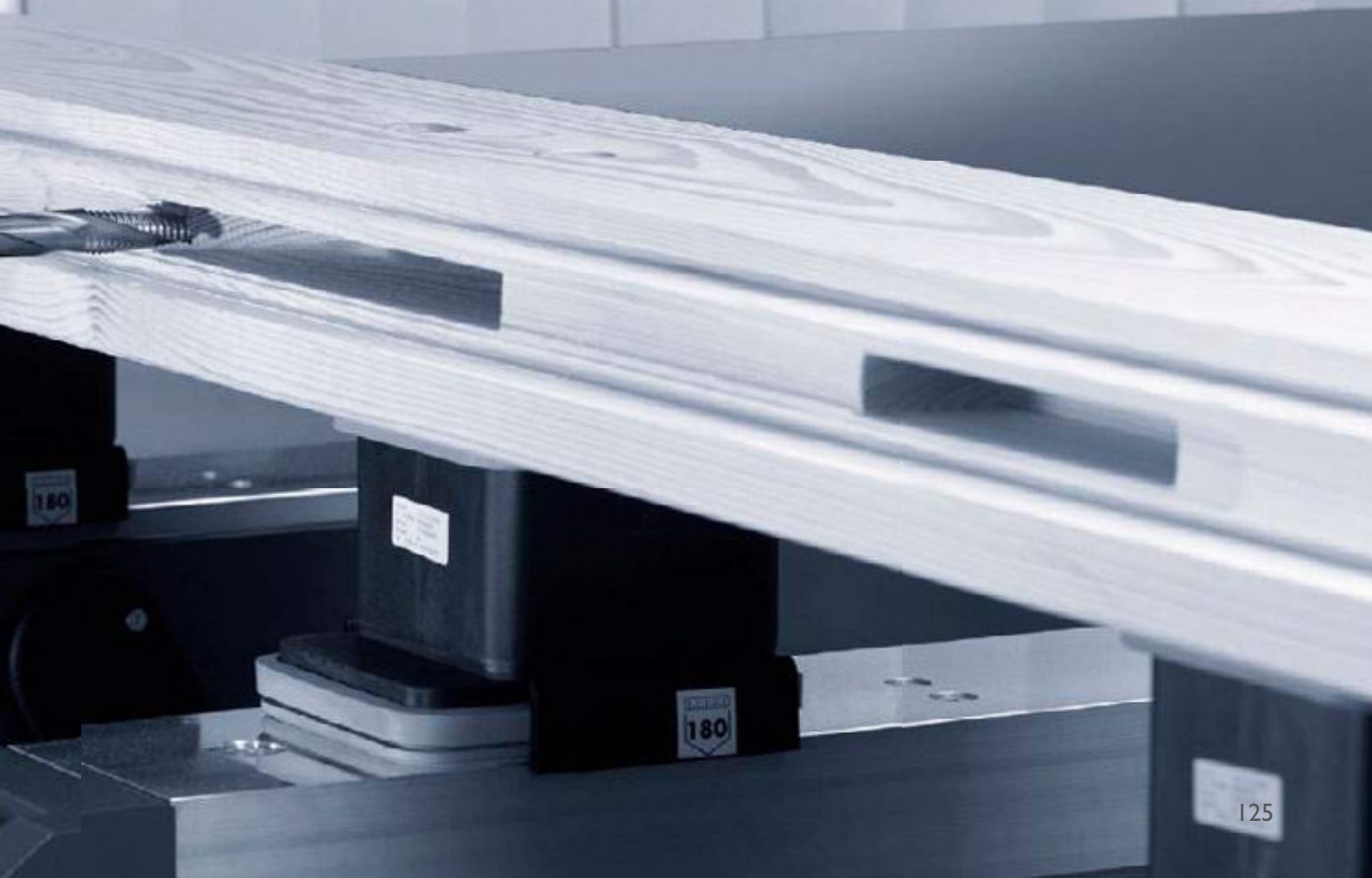

Outstanding productivity: FORMAT-4 CNC machine in your networked workshop

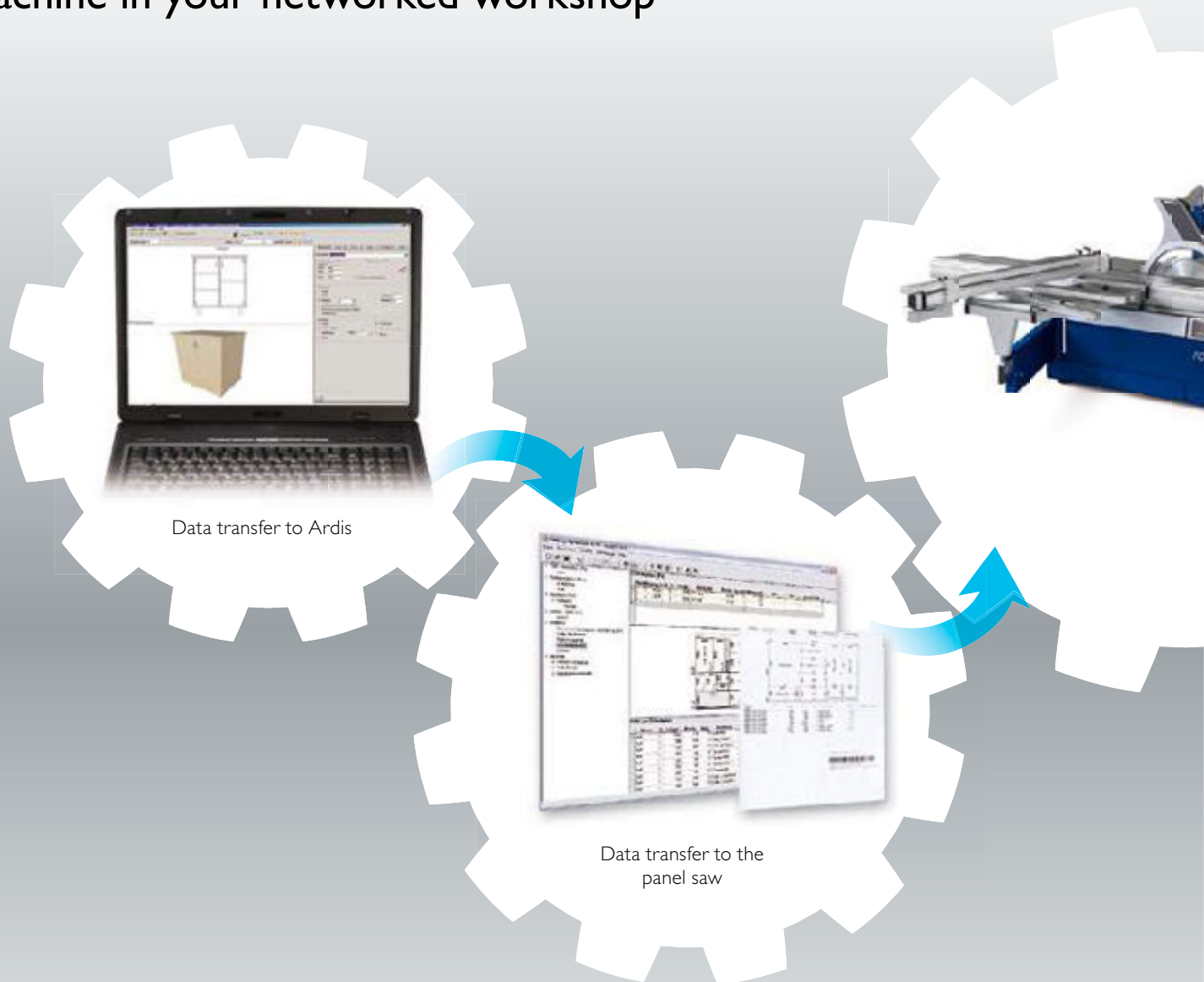

Planning with “Flash 3D”

Individual case furniture is created quickly and professionally, simply by inputting a few parameters into the “Flash 3D” software i. e. during a sales talk. The “Flash 3D” software automatically generates the data for:

- Presentation
- Construction
- Raw materials
- Production (CNC and edgebanders)

Cutting optimisation with Ardis

It is now incredibly easy to optimise cuts with the Format-4 panel saw as a result of the integrated Ardis cutting optimisation software. All the functions are clearly displayed on the user interface. You can check the tool width and the formatting cut quickly and easily as well as the cutting direction entered in the cutting list and the direction of the grain of the veneer.

Standard cuts and trimming

The optimised production data is transferred from the work planning stage to the panel saw via the network. The workflow is displayed on the panel saw’s TFT screen. The stops and cutting angles are positioned automatically. A label with barcode information can be printed for each workpiece.

Today's workshop: all machines are linked

Increase the productivity in your workshop and combine the "Flash 3D" with the "Wood-Flash" software from the work planning stage to the panel saw, CNC and edgebanders.

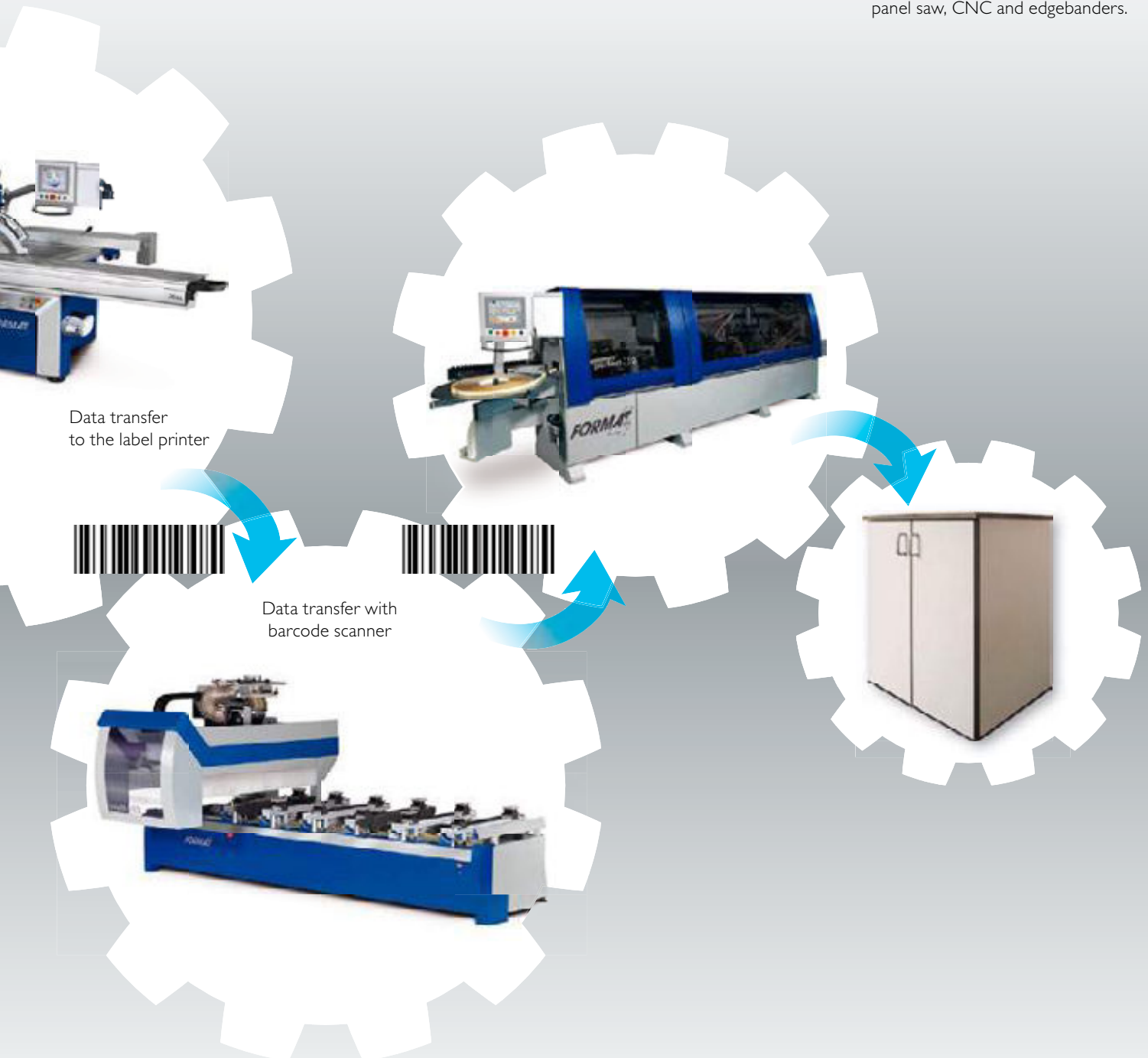

CNC machining

The appropriate program is loaded once the barcode has been scanned into the CNC. In IT-terminology, this process is known as "data import". Data imports eliminate errors and increase quality assurance; each workpiece machined is a quality product.

Edgebanding

Information such as the type of edging, the thickness and onto which side of the workpiece the edging is to be glued, is illustrated on the label, saving valuable production time!

The finished piece – completed in record time

The increase in productivity thanks to the Format-4 machines interconnected with a data network, is simply sensational. Whatever the workpiece, the use of a Format-4 production system will dramatically reduce the production time.

The solution for your future ...

How big is the step up really?

Craftsman's skill



Competitiveness/
Profitability

On the basis of a carpenter's skill the CNC broadens the current and future competitiveness and profitability of every workshop, in every market, in every sector.

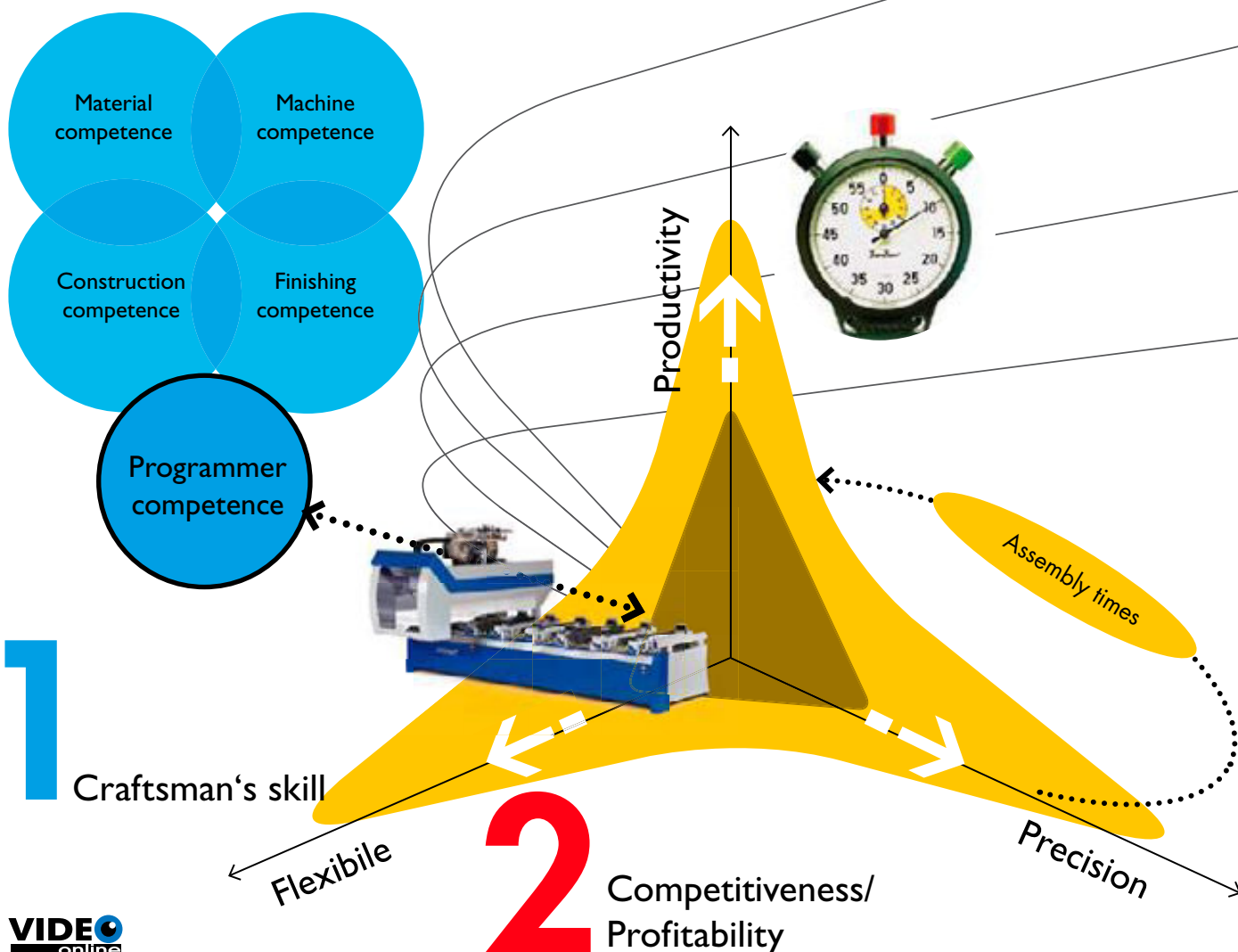

... increased productivity, more profitability

The CNC triangle opens up four directions for every workshop, in order to maximise profitability in a whole range of market scenarios.

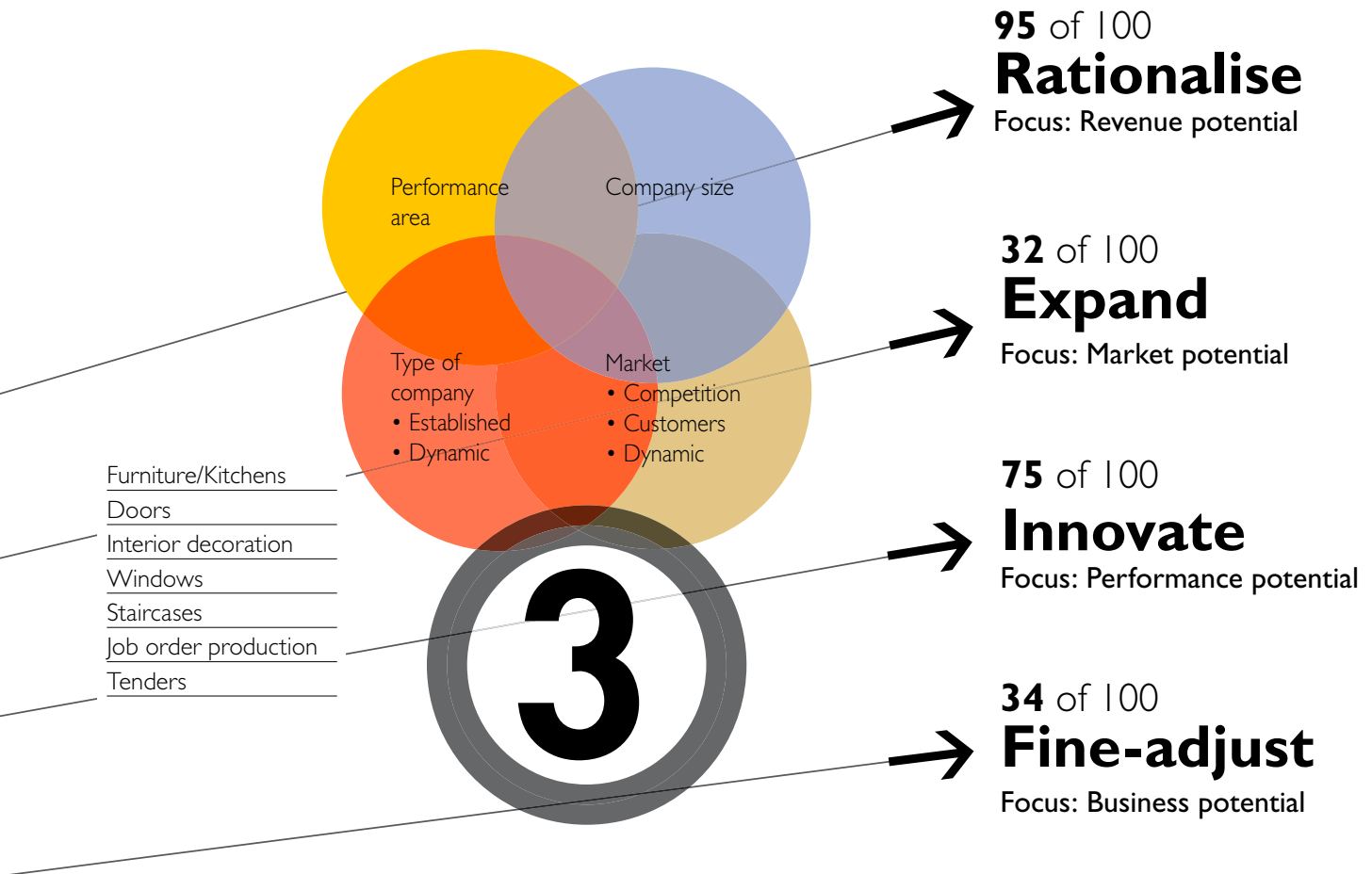

It is now commonplace for all woodworkers to setup and operate various types of machines with a range of tools in order to produce a finished product. The CNC operates along the same lines, but with an important difference: The production processes are merged together. Programmed by the operator and performed by the CNC.

The mechanisation of the workshop has been essential for decades.
When will your workshop take the next step?

The solution for your future ...

With FORMAT-4 CNC technology you can double the capacity and triple your profit in every production unit

WITHOUT CNC
approx. 29 hours

WITH CNC
in only 14 hours

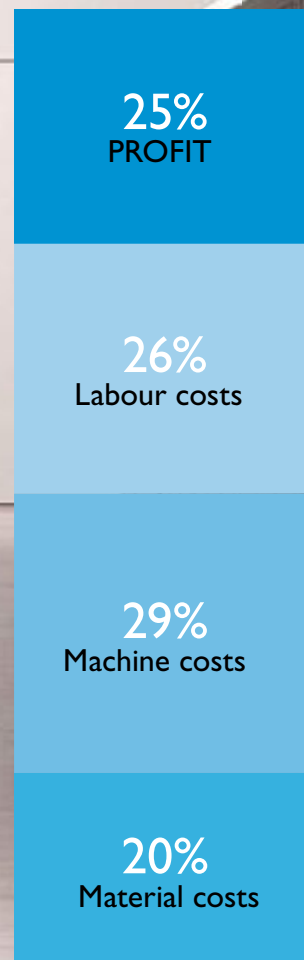
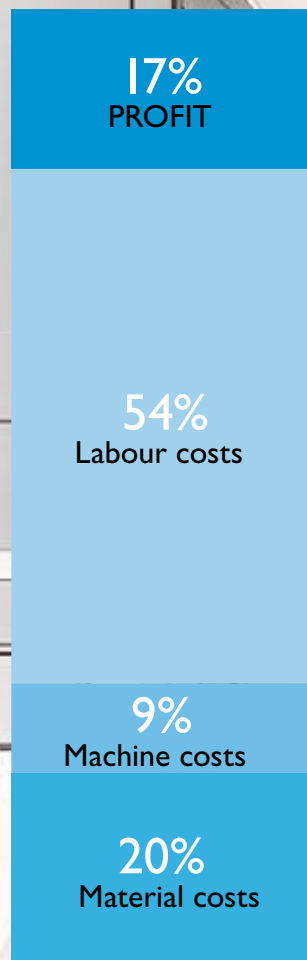

Data based on an independent, academic study on the production of an L shape kitchen with 89 workpieces. The production time includes all of the working processes, from planing to calculation, manufacturing and finally the end product. To see the complete report please contact our team of advisors.

Take the first step to more success with profit making CNC technology.
We will help you find a tailor made financing strategy for your desired investment.

... increased productivity, more profitability

6 reasons to go for a CNC! Today many woodworkers are fulfilling their dream of owning a CNC

"CNC is the standard machine of tomorrow!"

The things that seem difficult to us today, will become clear tomorrow! CNC machines are already playing a key role in every workshop. A CNC machine will enable unlimited options and possibilities for your workshop in the future.

1.

The standard machines of tomorrow

Programming within 3 days

Anyone with basic computer knowledge, who can draw their product and knows the required production steps, can develop a solid CNC programming base within 3 days.

2.

Easy to learn programming

Batch production efficient from the very first piece!

CNC is highly flexible and very customer orientated. CNC optimises the standard sector as well as the demanding non-standard sector. Once, twice, a hundred times...

3.

CNC = flexibility = individuality

Founded on carpentry skills!

The foundation on which the programming of a CNC is built, is carpentry skill. The ability to program the CNC improves profitability and competitiveness.

4.

Core competencies and profitability

CNC-Power is 3 dimensional

CNC broadens the competitiveness, as well as profitability over three central dimensions. It is a common misconception to view a CNC simply as a way to increase the speed of production.

5.

CNC is 3 dimensional

CNC requires big changes

CNC changes the carpenter trade significantly. The CNC redefines a woodworkers tasks!

6.

In summary

100 of 100 CNC users:
"CNC has become crucial to my work."

More easily programmed than expected: 78 out of 100

87 of 100 CNC users:
"My CNC expectations were exceeded."

Can one compete against CNC workshops without a CNC?
81 of 100 say no.



The solution for your future ...



Overview CNC machine range

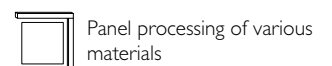
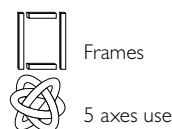
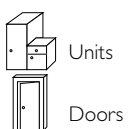
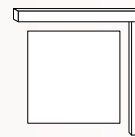
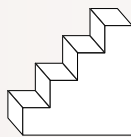
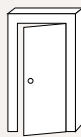
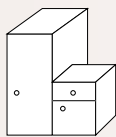
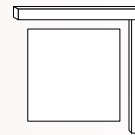
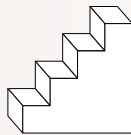
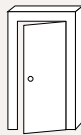
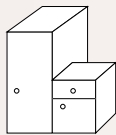
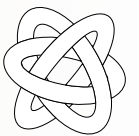
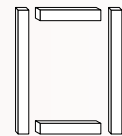
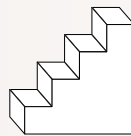
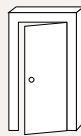
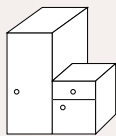
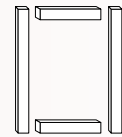
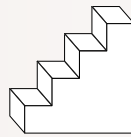
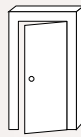
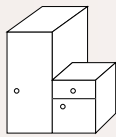
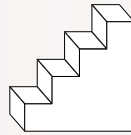
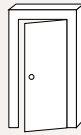
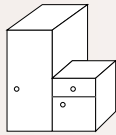
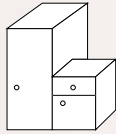



c-express 920

Complete processing of cabinets in only 2.5 m²

The Format-4 c-express 920 CNC drilling and milling machine executes all repeat drilling and simple milling work quickly, economically and precise. Developed specially for small workshops, the c-express 920 offers a sensational price-performance ratio. The uncompromising new release from the Felder Group is profit making CNC productivity in a nutshell. Repeat drilling programs can be recalled and reused at the touch of a button, workpiece after workpiece, order after order. The c-express 920 makes CNC controlled cabinet manufacturing profitable for every workshop, regardless of how much free space is available.



The CNC drilling and milling head

The c-express 920 is equipped with a DH14 6H 1S drilling head as standard. The 14 spindles can be individually equipped as required for the process to be carried out. The grooving saw is equipped with a scoring function and enables chip free cutting of rear walls or construction joints.

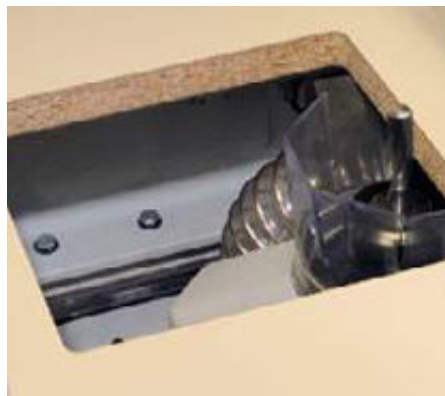

Milling unit

One of the specification options on the machine is the milling aggregate. The tooling is clamped using an ER 32 chuck. Changing of the tooling is carried out manually. This aggregate is used for the routing of cutouts, pockets, grooves and rebates.

- Compact CNC manufacturing in only 2.5 m²
- Highly precise 14 spindle drilling head for maximum flexibility
- Grooving saw as standard for the production of rear walls or construction joints
- Constant zero point as the panels are processed horizontally
- Maximum precision with modern laser technology
- Simple programming without consideration of the workpiece thickness



Workpiece transport/ unrestricted workpiece lengths

The horizontally designed transport system ensures the smooth transport and accurate positioning of workpieces of up to 30 kg in weight, allowing them to be processed from below by the aggregates. This design of the transport system prevents movement or burning of the workpieces by the tooling. This patented belt system ensures unlimited lengthways workpiece processing. The fence positioned on the side allows the width of the workpiece to be set at any value between 150–920 mm. The workpiece is then supported and guided from both sides guaranteeing a highly precise result.

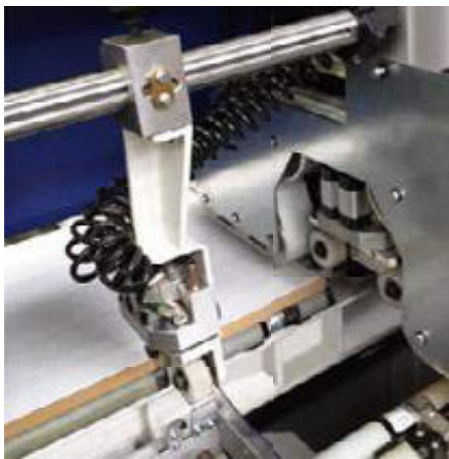

Roller pressure unit

When processing wide or thin workpieces the pressure device guarantees an exact processing depth.



Workpiece width 70 mm

An extra attachment for narrower workpieces enables the exact processing of workpieces of between 70 mm–150 mm in width.

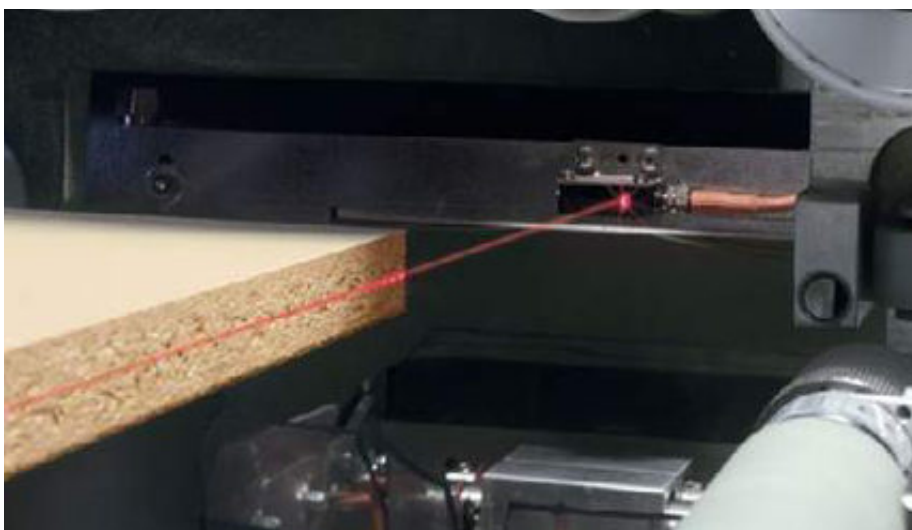

Next generation measuring technology

Modern measuring technology guarantees the highest measuring precision. An Encoder (distance measuring system and laser) measures the exact length of the workpiece. This ensures that construction connections (used predominantly in cabinet construction) can be done without any overhanging material.

Simple programming and operation

The Format-4 control systems have been specially developed for woodworking machines for drilling, milling and sawing. The operation is carried out via a graphical user interface (self-explanatory diagram display). The programming software "Wood-Flash" enables quick and easy programming of the workpieces. The 19" LCD colour monitor, clearly and simply displays all of the processes to be carried out on the workpiece. As an option it is possible to connect the machine with the cabinet programming software Flash 3D, that guarantees an even more rational processing of customer orders.

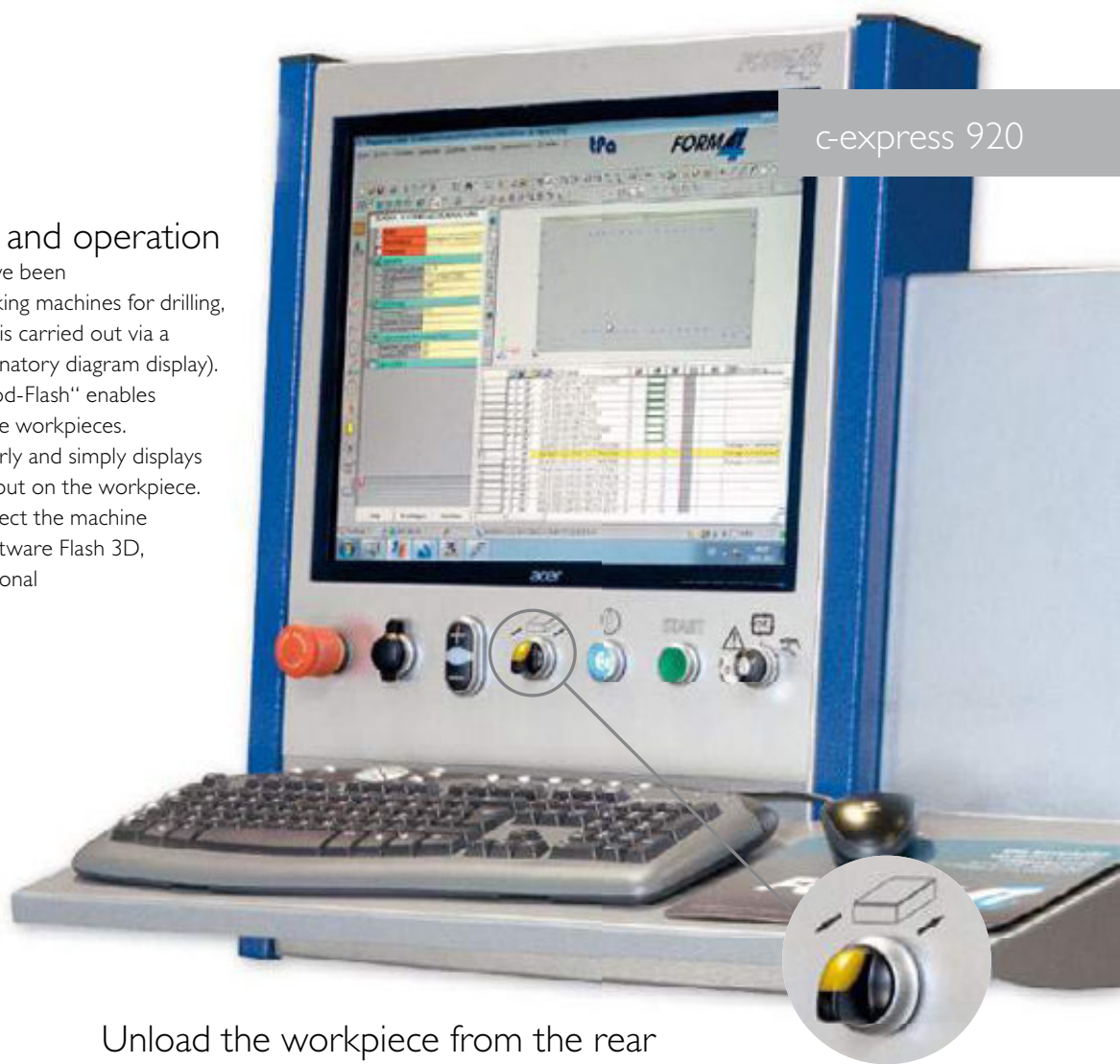

Unload the workpiece from the rear

This function allows the operator to program the machine to feed the workpiece to the rear when finished. This system allows the c-express 920 to be used in a production line. Selecting the unloading direction is done via this switch.

Space requirement

Scale
1:50

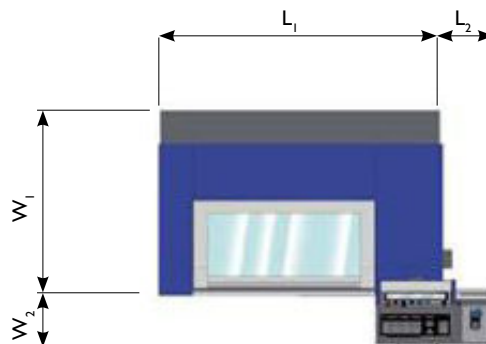

Symbolic image, c-express 920

Working areas

| | |
|---|-----------|
| X | unlimited |
| Y | 920 |
| Z | 50 |

| | c-express 920 |
|--------------------------|---------------|
| Height [H] | 1663 mm |
| Length [L ₁] | 1798 mm |
| Length [L ₂] | 320 mm |
| Width [W ₁] | 960 mm |
| Width [W ₂] | 338 mm |

Dimensions given can vary if special equipment is used



profit H20
profit H22
profit H22L

Profit making all-rounder

Common standard products or unique one-offs, the universal Format-4 CNC machining centres profit H20 and H22 offer maximum efficiency and profit making from day 1. The profit H22L CNC machine has been specially developed for the manufacturing of doors and stairs with the large working fields offering more than enough space for production maximising alternate processing.



Time saved

- Alternate operation
- Up to 4 work beds
- High traversing speed of the axes
- Solid loading supports enables productive single person operation

Comfort

- Hose-free vacuum, suction and clamping systems
- Laser supported vacuum pod positioning
- The hood leaves the complete working area free and guarantees a simple loading of workpieces especially larger dimensioned ones
- Up to 40 tool positions

Flexible

- Up to 270 mm tooling diameter
- The drilling head covers the whole working field, both horizontally and vertically
- Template function for complex workpiece contours
- Vacuum pod heights up to 100 mm

Quality

- Engineering quality from Austria
- High quality, solid machine components
- Automatic central lubrication ensures low maintenance

Working area



Hose-free

1 or 2 circuit system

The hose-free dual circuit system firstly fixes the vacuum pod in place and then the workpiece. This prevents the vacuum pod from moving unintentionally when loading the workpiece. (Vacuum pod 100 mm). On the profit H20 a single hose-free circuit system is used where the vacuum pod and workpiece are fixed in place simultaneously. Various Format-4 vacuum pods and frame clamps can be used to hold every conceivable size of workpiece quickly and safely.



Panel support and vacuum pods - quick positioning – maximum efficiency even in single person operation

The hose-free vacuum system can be adapted quickly and easily to the workpiece size and design. A large number of different vacuum pods can be used to fix every conceivable workpiece shape. A laser helps you to place the pods in a collision free position that has been calculated by the software. The hand-held terminal activates and positions the cross laser.

Linear positioning laser

Linear laser for the virtual zero point in the Y direction for the precise positioning of curved frame segments.



Rows of stops

Workpiece cylinder stops at
“double zero point” (second fence row)

In addition to the workpiece cylinder stops at the “standard zero point”, as an option, a second row of stops is available on each panel support to machine narrow workpieces on the front work bed.

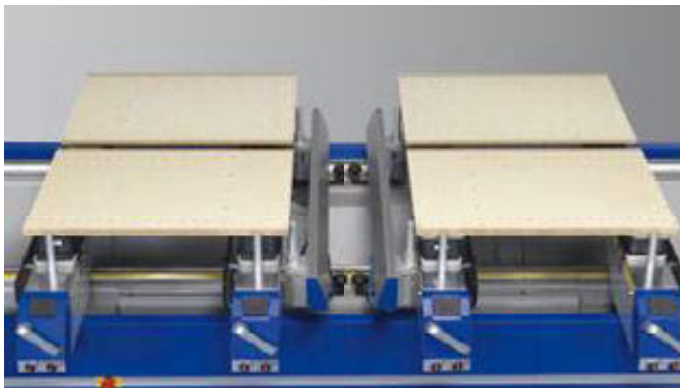

Central fences for the
Format-4 profit H22L.
The removable central
fences for 4 working fields
in the X direction.



Frame processing

Continuous fence in the Y direction for
an exact positioning of frame components.



Loading supports

Loading supports assist in the
simple clamping and unloading of
large or heavy workpieces. A major
advantage is that they enable you to
operate the CNC with one person.

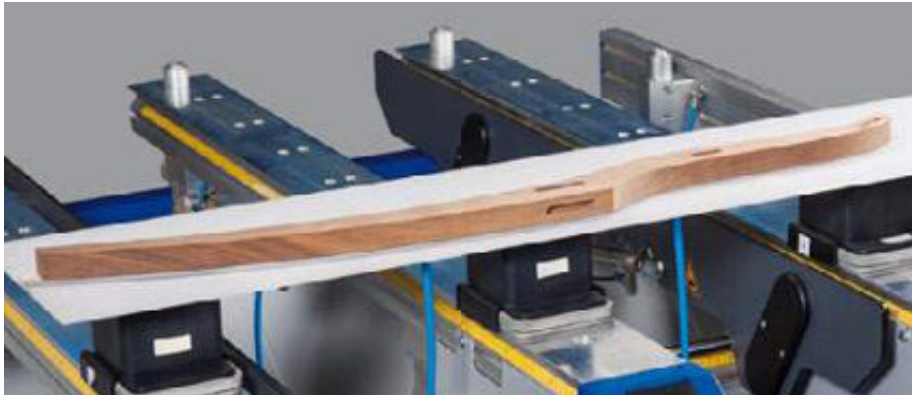

Template milling

For template milling there are 4 separate connections available on each operating field. With templates it is possible to process complex components that can not be held in place with vacuum pods.



Panel activation

Specially designed for use with compressed air controlled frame clamp systems, this function offers new possibilities and enormous clamping strength when it comes to the processing of solid wood. The ability to be able to deactivate the consoles individually makes it possible to remove waste material without having to release the vacuum holding the workpiece. This ensures that the workpiece stays in exactly the right position for the next working process (inner profiles etc.).



Workpiece stops for veneered panels

In addition to the standard workpiece cylinder stops, there are additional stops specifically developed to machine veneered panels with projecting veneer or laminate.



Panel support field configuration, clamping options

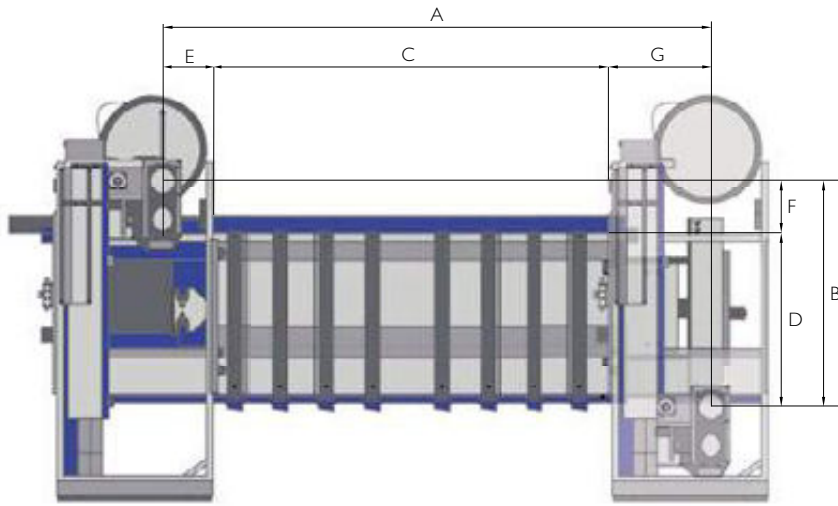

Working area, traverse distances

| profit H20/H22 | | profit H22L | |
|----------------|---------|-------------|---------|
| A | 3830 mm | A | 5920 mm |
| B | 1680 mm | B | 1680 mm |
| C | 3060 mm | C | 5020 mm |
| D | 1260 mm | D | 1260 mm |
| E | 628 mm | E | 628 mm |
| F | 420 mm | F | 420 mm |
| G | 142 mm | G | 142 mm |

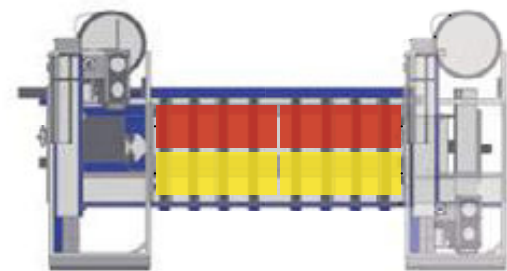

2 working fields in the X direction for alternate workpiece processing: with front and rear fences

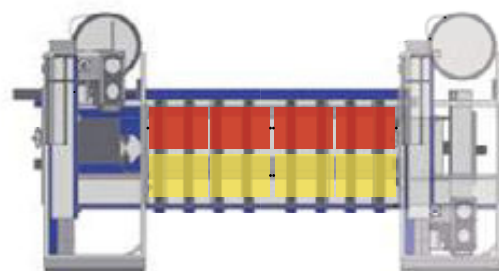

profit H22L: 4 working fields in the X direction with a central row in X for alternate workpiece processing: with front and rear fences

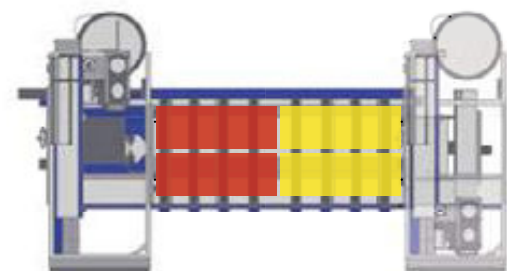

2 working areas in X-axis, 2 in Y-axis for alternate operation

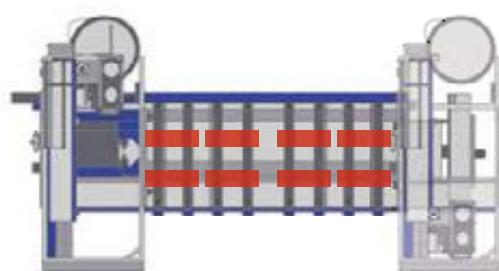

profit H22L: A working area for 8 workpieces to machine frames. Display using a linear laser

Drilling head



Drilling heads with 20 drilling spindles

- 14 vertical drilling spindles, spaced at 32 mm:
 - 9 in X and 5 in the Y axis, each available individually
- 6 horizontal drilling spindles, spaced at 32 mm:
 - 4 in X and 2 in the Y axis, each available individually
- Integrated slot cutter in the X-axis
- Inverter driven motor up to 7.500 rpm



DH 20 6H 1S



Optional DH 20 6H 2S

Highlight

The complete working field can be covered by the drilling group for vertical and horizontal drilling.

Spindle

With a motor power of 10 to 12 kW with up to 24.000 rpm and inverter controlled, the main spindle motor is more than capable to tackle any task. The motor is fixed directly on to the carrier unit in the Z-axis. The highly precise vertical guiding of the moulder motor is guaranteed by two vertical guide tracks. The HSK F63 tool clamping is carried out automatically. The clamping pressure of the tool is controlled by sensors and the operation safety guaranteed. The tooling housing is cleaned pneumatically. The C-axis is optionally as the available fourth axis and is interpolating (360°) with a compressed air interface for the units.



The horizontal drilling motor

With a motor power of 4.5 kW and 18.000 rpm the horizontal drilling motor is controlled by an inverter. Through the use of a variety of tooling for example a rebate or casing tool the processing opportunities are almost limitless, providing massive shape variety.

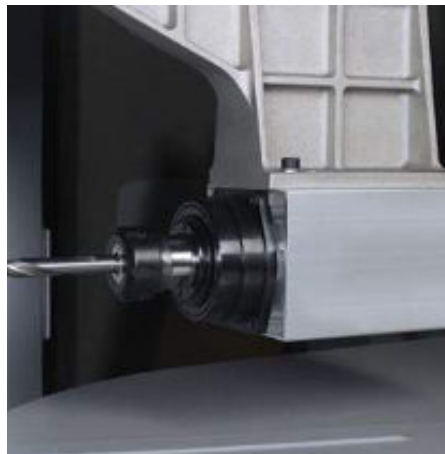

Chip deflector

A chip deflector mounted to the spindle controlled by the C-axis enables the unlimited use of existing tools. When machining the edge of a workpiece, dust and chips are directed into the extraction port.

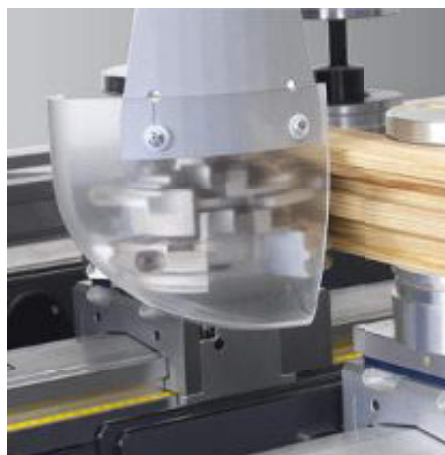

Vacuum connection

Ensures an efficient extraction result.

Tooling positions and space requirement

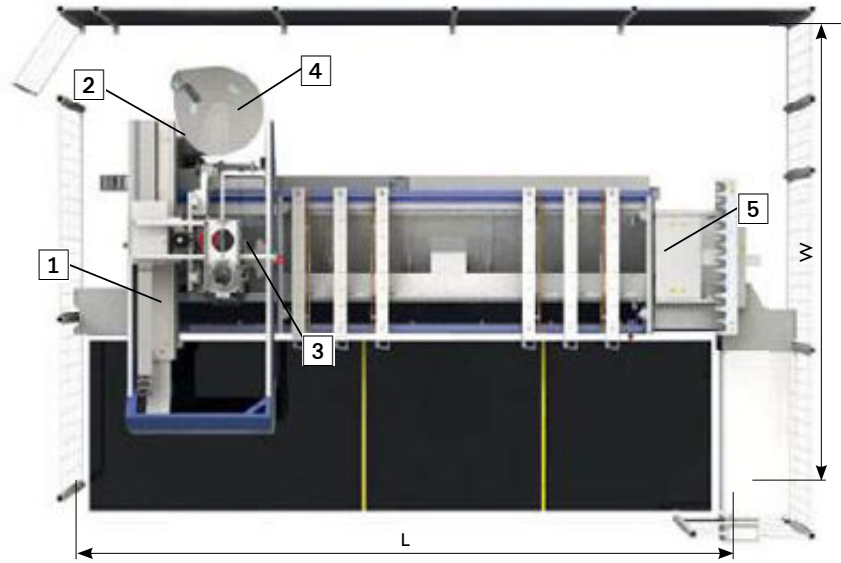

Symbolic image, profit H20, profit H22, profit H22L

| | profit H20 | profit H22 | profit H22L |
|------------|------------|------------|-------------|
| Height [H] | 2241 mm | 2241 mm | 2241 mm |
| Length [L] | 6350 mm | 6350 mm | 8435 mm |
| Width [W] | 4450 mm | 4450 mm | 4450 mm |



1 8 position linear tool changer mounted to the outrigger
A linear tool changer, with up to 8 different tool positions, mounted to the outrigger ensures massive machining diversity.



2 Single position pick up
Tooling pick-up and aggregate position at the rear of the outrigger for larger dimensioned tooling up to Ø 270 mm.



3 2 position pick up
and aggregate position on the left of the machine chassis for larger dimensioned tooling up to Ø 270 mm.



4 8-Position Rotary Tool Changer mounted to the outrigger
The rotating changer with 18 tool positions is mounted at the back of the outrigger and moves with the outrigger along the X-axis. The 18-position rotating tool changer, keeps tooling changing times to the bare minimum making the Format-4 machining centre even more efficient!



5 12 position linear tool changer mounted on machine chassis
The tool changer with 12 tooling positions improves productivity and creates more space for additional tools on the machine.

Dimensions given can vary if special equipment is used

Vacuum and clamping systems

Vacuum pod variations for hose-free single and dual circuit systems



Vacuum Pods “Schmalz” Dual Circuit Panel Support System profit H20/H22/H22L/H50/H50L

| POS | Description | L x W | X/Y |
|-----|-------------|-----------------------------------|-----|
| 1 | Vacuum pods | 140 x 115 | - |
| 2 | Vacuum pods | 125 x 75 | X |
| 3 | Vacuum pods | 125 x 75 | Y |
| 4 | Vacuum pods | 125 x 75 (rotatable through 360°) | - |
| 5 | Vacuum pods | 125 x 50 | X |
| 6 | Vacuum pods | 125 x 50 | Y |
| 7 | Vacuum pods | 125 x 50 (rotatable through 360°) | - |
| 8 | Vacuum pods | 130 x 30 | X |
| 9 | Vacuum pods | 130 x 30 | Y |



Perfect nesting with the FORMAT-4 matrix table

The matrix table with optimised grid geometry can be placed directly on the console and allows the full surface support of workpieces of all designs and sizes and guarantee their exact positioning.

Frame clamping device



Frame clamping device, can be used for all clamping ranges and every shape of frame

2 vacuum circuits hold the frame clamping device onto the panel support and locking clamps ensure accurate repeatability. The clamping is powered with compressed air at 6 bar. The ability to lower the base plate by 3 mm (except in position 19) facilitates clamping from the inner to the outer profile. Diverse plate shapes are available depending on the clamping power required.

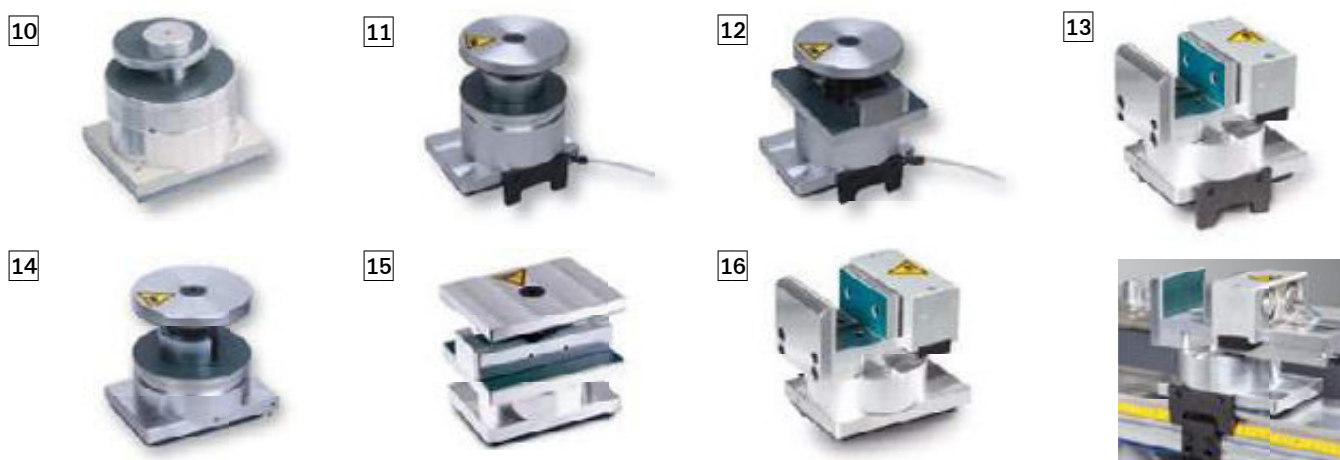

Fixing clamp

Frame clamping device profit H20/H22/H22L/H50/H50L

| POS | Description | Clamping range |
|-----|--|----------------|
| 10 | Frame clamping device (using a vacuum system) | 45–95 |
| 11 | Frame clamping device (with fixing cover plate via compressed air) | 45–95 |
| 12 | Single piece frame clamping device (with fixing cover plate via compressed air) | 45–95 |
| 13 | Frame clamping device with a horizontal clamping system (with fixing cover plate via compressed air) | 10–130 |
| 14 | Frame clamping device e-motion panel support (using compressed air) | 55–105 |
| 15 | Single piece frame clamping device (using compressed air) | 55–105 |
| 16 | Frame clamping device e-motion with horizontal clamping | 10–130 |



Accessories Frame clamping device profit H20/H22/H22L/H50/H50L

| POS | Description | Clamping range |
|-----|----------------------------|----------------|
| 14 | Clamping plate | 15–65 |
| 15 | Clamping plate | 55–105 |
| 16 | Tear-shaped clamping plate | 45–95 |
| 17 | Tear-shaped clamping plate | 55–105 |
| 18 | Clamping plate Rectangular | 55–105 |

Application examples



Steps/staircase production

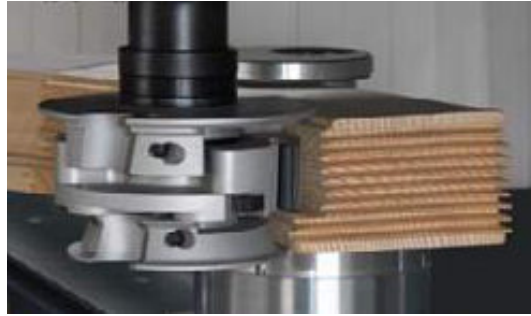

Solid wood manufacturing



Interior doors, front doors



Template milling



Case furniture production



Window production

Workpiece examples

Unlimited processing possibilities for a variety of shapes and uses

The Format-4 programming software is of significant support to the high flexibility and fast operational times of your CNC profit H20, H22 and H22L machining centres. The software enables fast and profitable machining of any single workpiece, whether simple or complicated! The Format-4 programming software has numerous functions, is incredibly advanced yet self-explanatory.



Diverse materials: Plastic, Alucobond, mineralised materials, packaging materials

The variable speed (max 24.000 rpm) and the variable operating speed in combination with the appropriate tooling guarantees great results even when processing plastics. Whether its very thin pieces using templates or heavier workpieces, Format-4 always has the right solution.

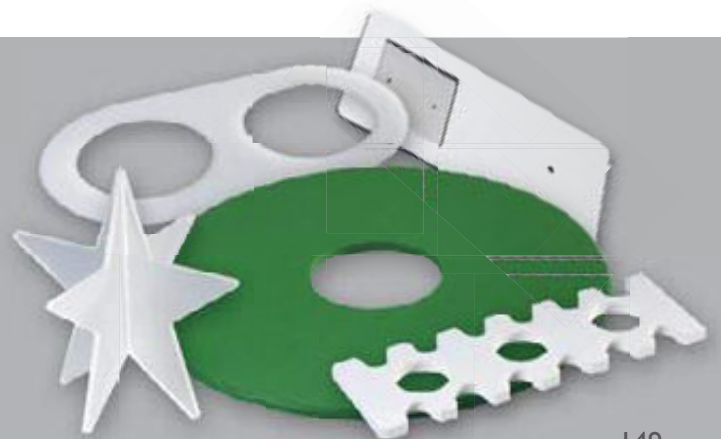

Units



HSK F63 Single angle head to fit a drill or spindle moulder bit with one output
Order no. 300-24-001

HSK F63 single angle cutter head, accepts a screw mounted saw blade with one WELDON output,
 max. Ø 180 mm **Order no. 300-24-002**
 max. Ø 240 mm **Order no. 300-24-003**
 max. Ø 300 mm **Order no. 300-24-007**

HSK F63 single angle cutter head, accepts a saw blade with one output, (ATLOCK-lock)
 max. Ø 240 mm **Order no. 300-24-009**
 max. Ø 300 mm **Order no. 300-24-008**



HSK F63 Lock recess aggregate with 2 ER 25 outputs for drilling or milling tooling and two compressed air dust removal jets
Order no. 300-24-017

HSK F63 Floating unit with tracer for vertical routing of exact milling depths HSK F63
Order no. 300-24-010

HSK F63 Corner notching unit
Order no. 300-24-022



HSK F63 Dual angle head with 2 outputs ER 25, for drill and milling tools
Order no. 300-24-011



HSK F63 Dual angle head with 1 output for drill-, milling tool and 1 ER 25/WELDON output with screw mounted saw blade, max. Ø 180 mm
Order no. 300-24-012



HSK F63 Four-sided angle head with 2 outputs 2x ER 25 for drill-, milling tool and 2 outputs 2x ER32
Order no. 300-24-014
4 Exits ER 25
Order no. 300-24-015



HSK F63 3+1 angle head with 10 mm chucks, spaced at 22 mm
Order no. 300-24-016



HSK F63 Single ER 25 output tilting head for use with drill, milling or saw tooling max. Ø 180 mm
Order no. 300-24-005



HSK F63 WELDON single output tilting head for use with drill, milling or saw tooling max. Ø 180 mm
Order no. 300-24-006



HSK F63 WELDON Single output tilting head for use with drill, milling or saw tooling max. Ø 240 mm
Order no. 300-24-020



HSK F63 Single ER 25 output tilting head for use with drill, milling or saw tooling max. Ø 240 mm
Order no. 300-24-013



HSK F63 tilting aggregate, digital with ET interface, max. Ø 180 mm, Angle adjustment and quick lock
Order no. 300-24-023



HSK F63 tilting aggregate, digital with ET interface, max. Ø 240 mm, Angle adjustment and quick lock
Order no. 300-24-024



HSK F63 Single output tilting ER 25 head for use with drill, milling or saw tooling, max. Ø 180 mm, Angle adjustment and quick lock
Order no. 300-24-025



HSK F63 Dual angle head with 2 outputs ER 25, for drill and milling tool, Angle adjustment and quick lock
Order no. 300-24-026

ET interface

- Repeatability
- Saves time when changing tooling
- Exact readout of the angle accurate to a tenth of a degree
- Fixed positioning (0, 90, 45)

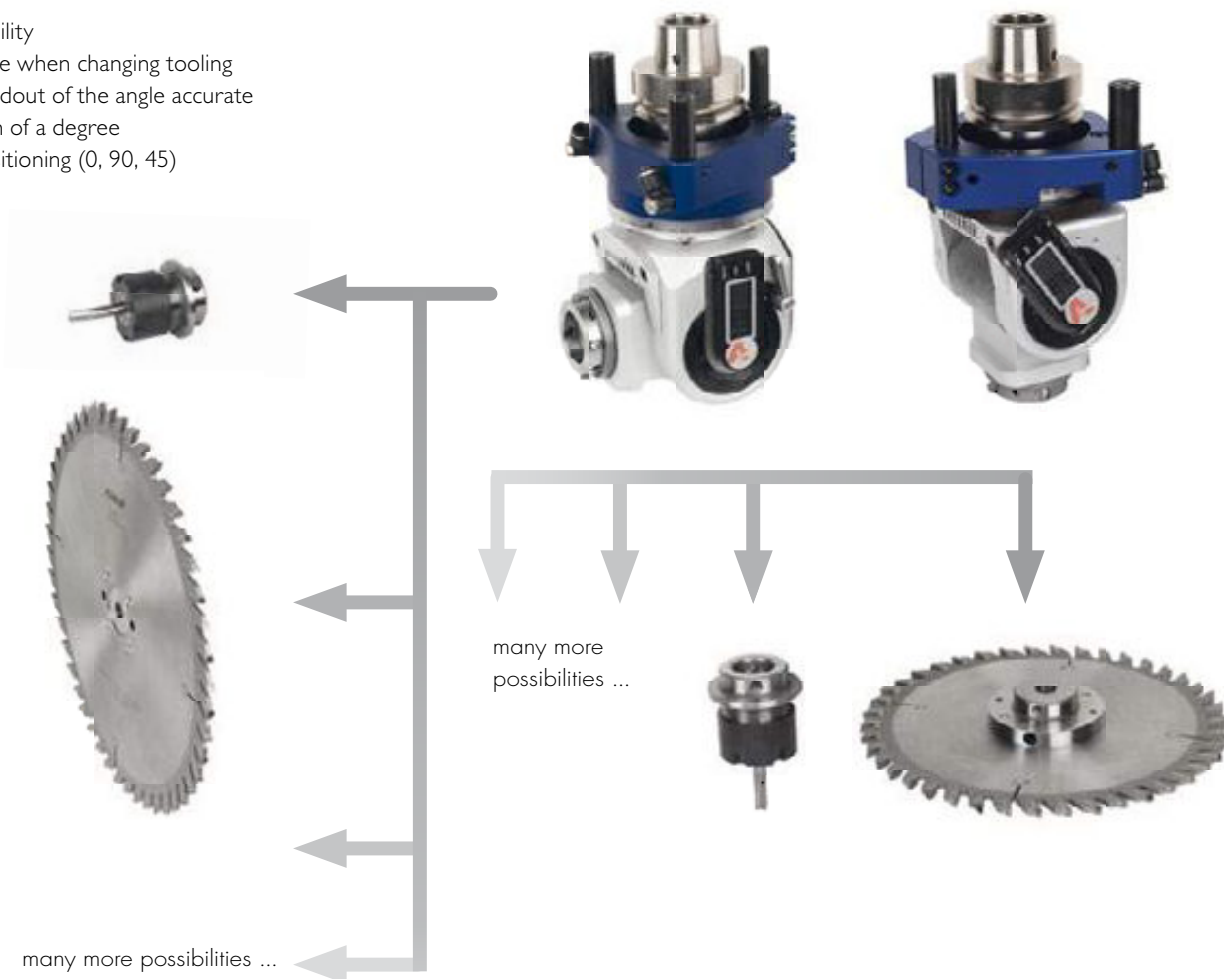

Accessories for the ET interface



ET adapter for the mounting of tooling onto aggregates with an ER 25 interface mini adapter for ET interfaces
Order no. 300-24-028



ET adapter for the mounting of tooling onto aggregates with a Weldon ET interface adapter for ET interfaces
Order no. 300-24-030

ET adapter for the mounting of tooling onto aggregates with a Clamex ET interface adapter for ET interfaces
Order no. 300-24-027

ET adapter for the mounting of tooling onto aggregates with an ER32 ET interface adapter for ET interfaces
Order no. 300-24-029

ET adapter for the mounting of tooling onto aggregates with an ET-set (1x Weldon/2x ER 25) ET interface
Order no. 300-24-0231

ET adapter for the mounting of tooling onto aggregates with an ET-set (2x Weldon/1x ER 25) ET interface
Order no. 300-24-0232

5-motion, the special unit from FORMAT-4

The 5-axis unit from FORMAT-4

Automatically fully adjustable

The "5-motion" automatic adjustable tilting unit by Format-4 enables every CNC machine to upgrade to a 4-axis and 5-axis CNC machine; it is also a cost-efficient way of doing so.

This small investment yields high cost savings! Investing in a Format-4 "5-motion" automatic adjustable tilting unit will increase the performance and the efficiency of your CNC machine. The Format-4 "5-motion" automatic adjustable tilting unit reduces the need to invest in additional and necessary tools or units. In addition, shorter machining times (fewer tool changes per workpiece) save time and therefore money. Not only does a Format-4 "5-motion" unit ensure every business a fast repayment of the initial outlay costs but creates more value out of the current CNC machine.



5-motion^{plus}

The FORMAT-4 5-axis unit with tool interface

The "plus" stands for more tools which can be inserted within a program. The 5-motion^{plus} unit can automatically change saw, drill and moulder bits within a program sequence. The interface of the 5-motion^{plus} unit enables the tools to be changed in the rear tool changer at the same speed as a standard tool changer.

The Format-4 5-motion^{plus} unit impresses with its unlimited flexibility and versatility.

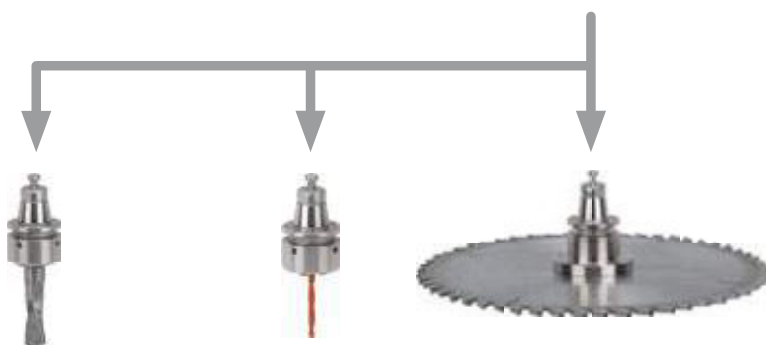



profit H50 profit H50L

One machine, five axes, limitless possibilities

The individual processing of different materials is becoming an ever more important factor in universal workshops. The highly precise 5 axes spindle guarantees limitless creativity and reduces at the same time the initial investment and subsequent costs for special aggregates and tooling. Individual tooling configuration and fully automatic production for a conceivable investment amount - the Format-4 profit H50 makes the future of component manufacturing affordable.

The machine illustrations may show optional equipment. Please refer to your individual quote for clarification on which options are included.



Time saved

- 5 axes processing instead of having to change the tooling frequently
- 2 CNC controlled Z-axes for the shortest of production cycles
- Up to 8 working fields for maximum productivity
- E-motion consoles enable automatic positioning of the consoles and vacuum pods

Comfort

- Up to 59 tool slots
- Hose-free vacuum, suction and clamping systems.
- Laser supported vacuum pod positioning
- The hood leaves the complete working area free and guarantees a simple loading of workpieces especially larger dimensioned ones

Flexibile

- Maximum 350 mm saw blade diameter
- Up to 350 mm working height from the level of the consoles
- Variable positionable CNC controlled extraction hood for great extraction results
- The drilling head covers the whole working field, both horizontally and vertically
- Several aggregates can be combined with the 5 axes spindle

Quality

- Engineering quality from Austria
- High quality, solid machine components
- Liquid cooled main spindle as standard
- Automatic central lubrication ensures low maintenance

Working area

Console and vacuum pod positioning - high efficiency for single person operation

The hose-free vacuum system can be adapted quickly and easily to the workpiece size and design. A large number of different vacuum pods can be used to fix every conceivable workpiece shape. A laser helps you to place the pods in a collision free position that has been calculated by the software. The hand-held terminal activates and positions the cross laser.

Hose-free FORMAT-4 dual circuit system with 100 mm vacuum pod height

The dual circuit vacuum console with manual pod positioning prevents any unintentional movement of the clamps on the workpiece surface. Different Format-4 vacuum pods can be used to fix all possible workpiece shapes in place quickly and safely.

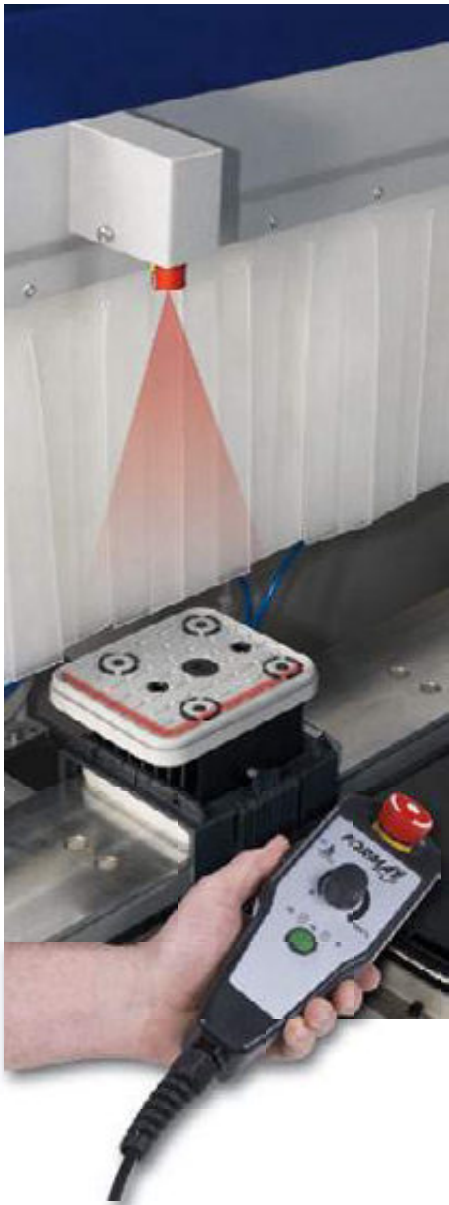

Optional extras

Continuous fence in the Y direction for an exact positioning of frame components.

Rows of stops



Workpiece cylinder stops at “double zero point” (second fence row)

Additionally to the workpiece fence cylinder at the standard zero point, there is a second row of fences on each of the consoles in the front working field which is of particular advantage when processing narrow workpieces.

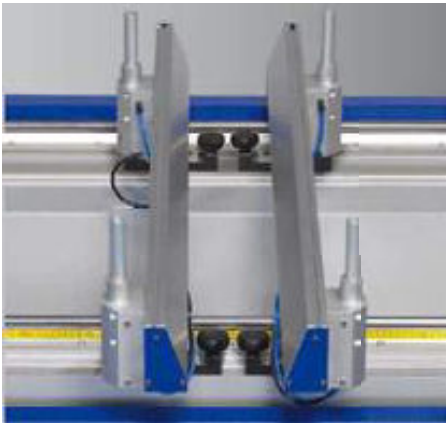

Central row of fences for the Format-4 profit H50L and a removable central fence for 2 working fields in the X direction.



The “e-motion” panel support

The fully automatic “e-motion” panel support enables fast and top quality all-round machining of windows and door frames.



Quick, hose-free change from frame clamping devices to vacuum pods, without any additional setting changes being required.



Linear positioning laser

Linear laser for the virtual zero point in the Y direction for the precise positioning of curved frame segments.

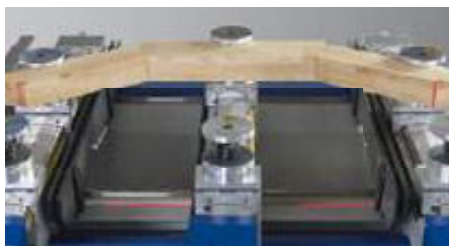

Dual line laser

If required, a dual line laser is available to enable workpieces to be positioned onto divided working areas. This dual line laser is positioned in the centre of the working area in the X-axis.



Loading supports

Loading supports assist in the simple loading and unloading of large or heavy workpieces. A major advantage is that they enable you to operate the CNC with one person.



Dual level loading supports for the processing of frames

Loading supports with 2 levels: The frame is positioned with the frame clamps on the inside of the frame so that the outer profile can be processed. The loading supports then drop to the next level, where the frame clamps can then grip the workpiece.



Template milling

For template milling there are 4 separate connections available on each operating field. With templates it is possible to process complex components that can not be held in place with vacuum pods.



Workpiece stops for veneered panels

In addition to the standard workpiece cylinder stops, there are additional stops specifically developed to machine veneered panels with projecting veneer or laminate.





Panel activation

Specially designed for use with compressed air controlled frame clamp systems, this function offers new possibilities and enormous clamping strength when it comes to the processing of solid wood. The ability to be able to deactivate the consoles individually makes it possible to remove waste material without having to release the vacuum holding the workpiece. This ensures that the workpiece stays in exactly the right position for the next working process (inner profiles etc.).

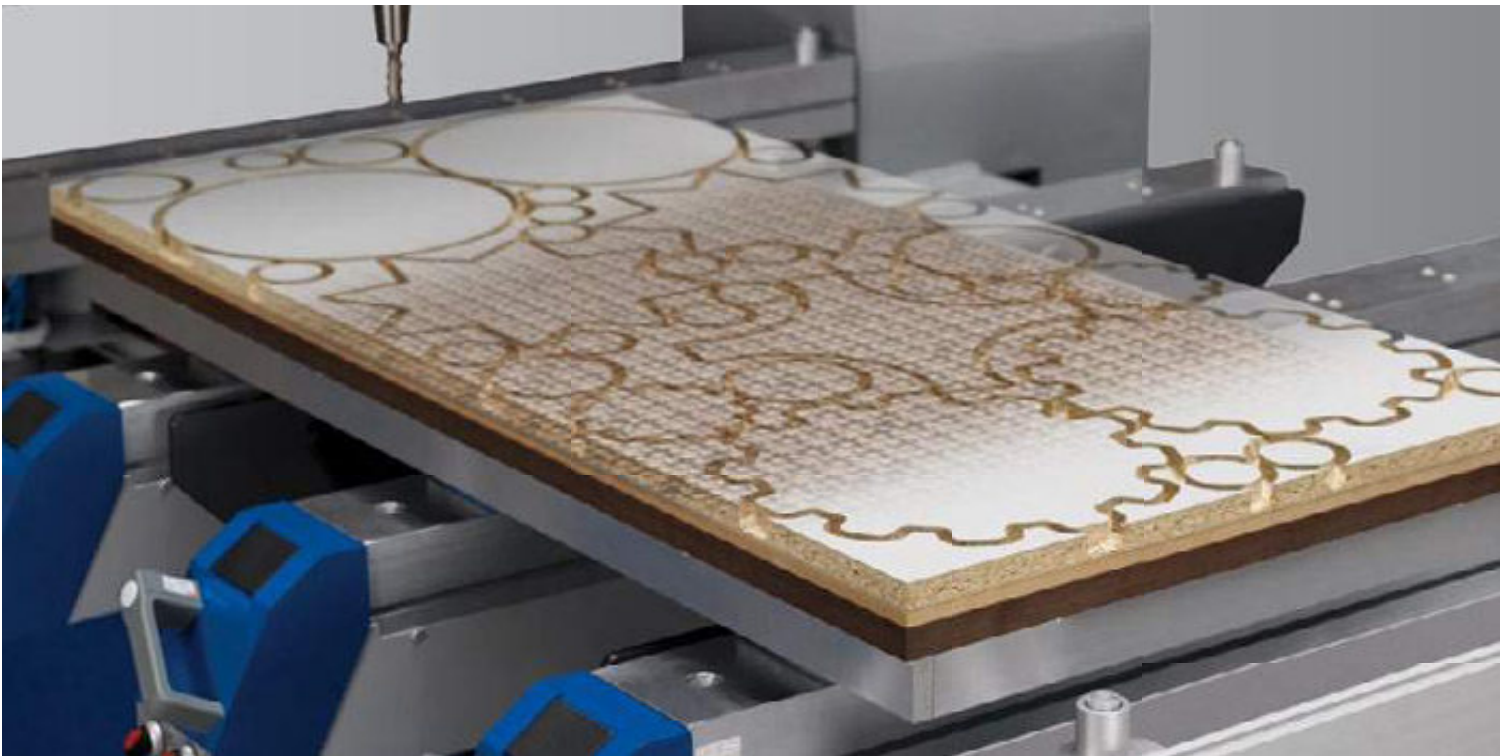

Perfect nesting with the FORMAT-4 matrix table

The matrix table with optimised grid geometry can be placed directly on the console and allows the full surface support of workpieces of all designs and sizes and guarantee their exact positioning.

Panel support field configuration, clamping options

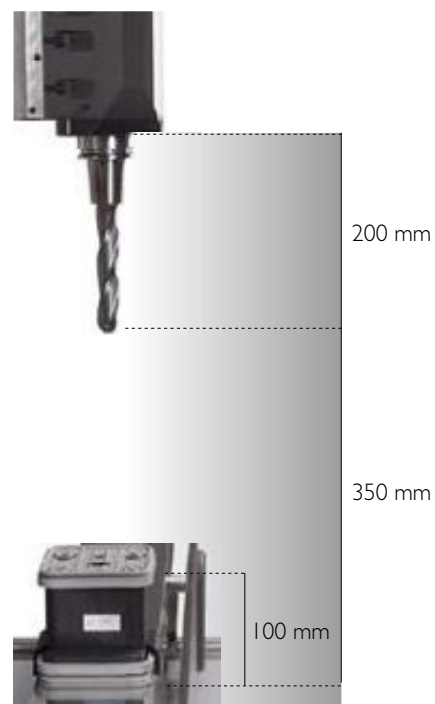
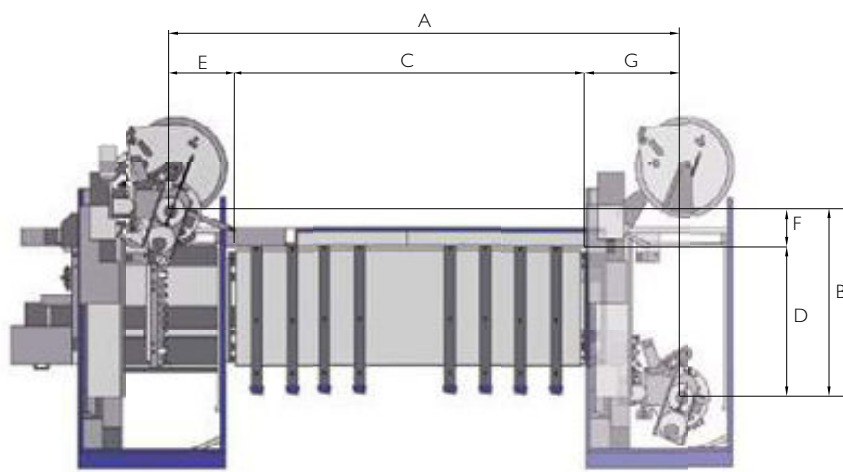

Working area, traverses distances

profit H50

- A 4930 mm
- B 1925 mm
- C 3740 mm
- D 1570 mm
- E 690 mm
- F 420 mm
- G 500 mm

profit H50L

- A 6730 mm
- B 1925 mm
- C 5540 mm
- D 1570 mm
- E 690 mm
- F 420 mm
- G 500 mm

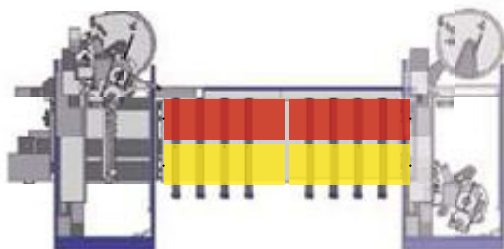

2 working fields in the X direction for alternate workpiece processing: with front and rear fences

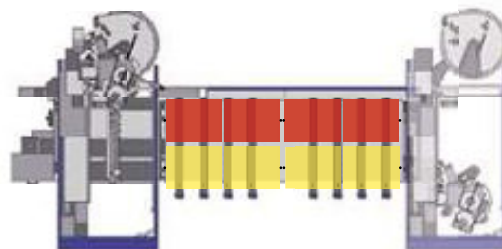

profit H50L: 4 working fields in the X direction with a central row in X for alternate workpiece processing: with front and rear fences

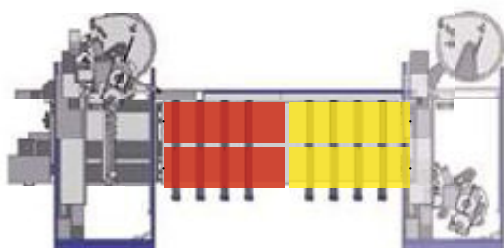

2 working areas in X-axis, 2 in Y-axis for alternate operation

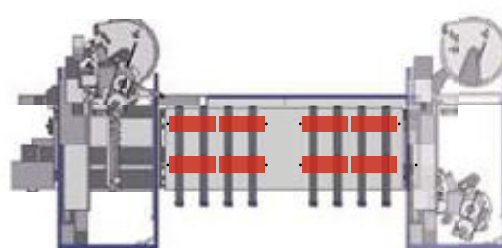

profit H50L: A working area for 8 workpieces to machine frames



Unlimited processing possibilities with the FORMAT-4 drilling head and the powerful 5 axes spindle

Drilling head

Drilling head with 18 drilling spindles

- 12 vertical drill spindles, spaced at 32 mm: 7 in the X- and 5 in the Y-axis, always individually retrievable
- 6 horizontal drill spindles, spaced at 32 mm: 4 in the X- and 2 in the Y-axis, always individually retrievable
- Integrated slot cutter in the X-axis
- Inverter driven motor up to 7.500 rpm

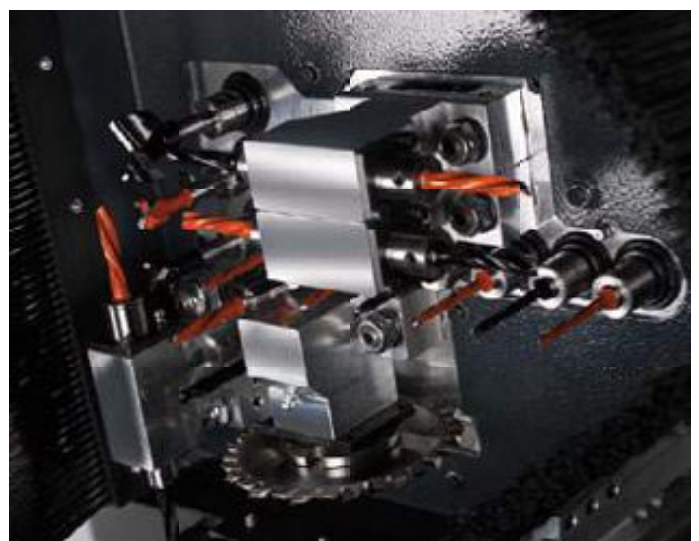

DH 18 6H 1S

Highlight

The complete working field can be covered by the drilling head for vertical and horizontal drilling.

The main spindle: 5 axes - no restrictions

The powerful 5 axes spindle with 12 or optionally 15 kW motor guarantees excellent results whilst milling, drilling and sawing at any angle. The special liquid cooling and high quality ceramic bearings ensure durable precision and incredible smoothness regardless of the material. An inverter regulates the speed and can be set at any speed up to 24.000 rpm.



Variably positionable extraction hood
The extraction hood positions itself fully automatically to the workpiece height which significantly reduces the dust and noise emissions.

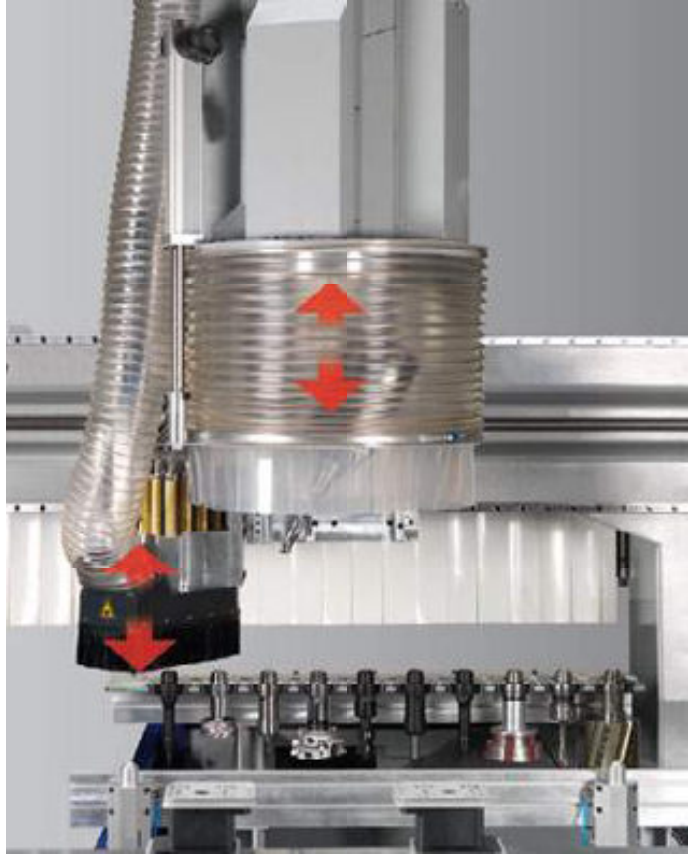

2 CNC controlled Z axes
The aggregate carrier with two Z axes enables the quick, diverse use of drilling head and main spindle. The traverse distance of the Z axis is 500 mm, ensuring that both long and high workpieces can be processed with ease.



Program controlled extraction connection
Ensures an efficient extraction result.



Chip removal system
Motorised conveyor belt to remove chips and waste material.

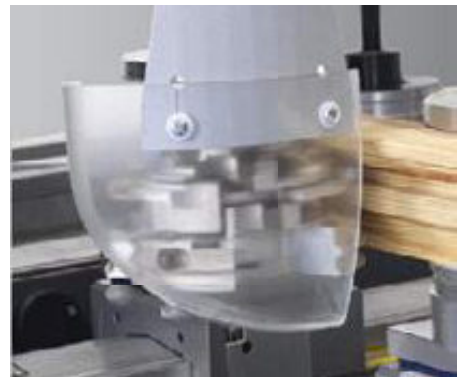

Chip deflector
A chip deflector on the moulding aggregate controlled by the C-axis enables the unlimited use of existing tools. When machining the edge of a workpiece, dust and chips are directed into the extraction port.

Tooling positions and space requirement

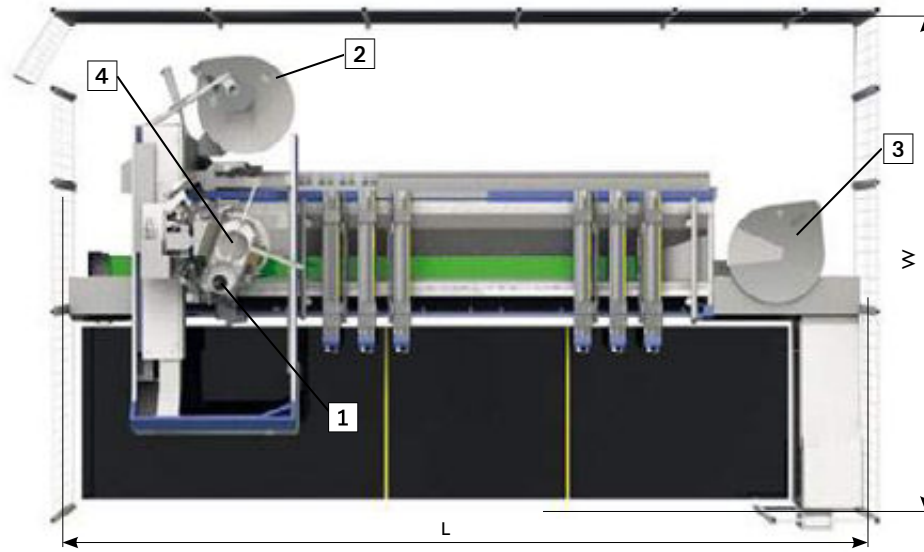

Symbolic image, profit H50, profit H50L

| | profit H50 | profil H50L |
|------------|------------|-------------|
| Height [H] | 2640 mm | 2640 mm |
| Length [L] | 8000 mm | 9800 mm |
| Width [W] | 4950 mm | 4950 mm |



1 10 position linear tool changer mounted to the machine chassis

Optional: the linear tool changer with up to 12 tool positions broadens productivity and makes way for additional tools. The linear tool changer with up to 10 tool positions increases productivity and makes way for additional tools.



2 24-position rotary tool changer mounted to the outrigger

The rotating changer with 24 tool positions is mounted at the back of the outrigger and moves with the outrigger along the X-axis. The 24 position rotating changer ensures that, tooling times are kept to the bare minimum making the Format-4 machining centre even more efficient.



3 An additional 24 position rotary tool changer

A second rotary tool changer with space for 24 tools is positioned on the side of the machine chassis and ensures an even quicker production cycle.



4 Saw blade changer

Travels with the outrigger for saw blades with a max. Ø 350 mm.

Dimensions given can vary if special equipment is used

Application examples



Simultaneous 5 axis processing



Doors



Process from below the zero level



Door frame manufacturing



Corner contours



Lock recess



Staircases



CNC processing in every format



Case furniture production



Clamex-P



Clamex-P



3D applications

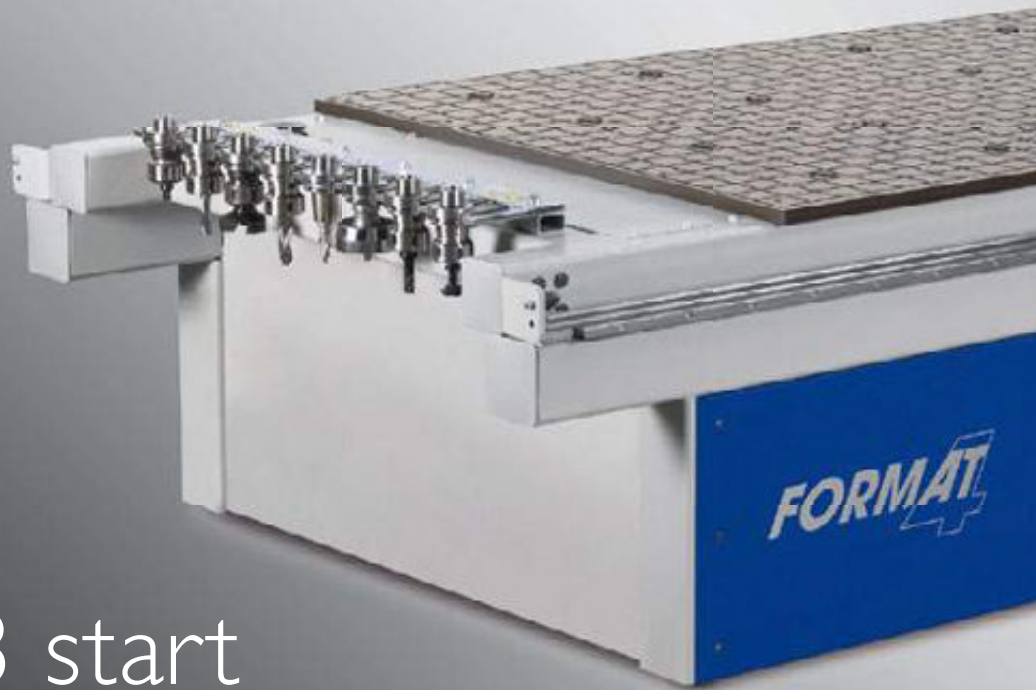

profit H08 start profit H08 professional

CNC-Nesting - Efficiency in the smallest of spaces

The profit H08 from Format-4 is the CNC machining centre for professional nesting applications in the smallest of spaces. Designed specifically for universal purposes, the high precision and productivity achieved when processing varying materials particularly impresses about this profit making all-rounder.



Time saved

- CNC cutting, milling, drilling and nesting in one work process
- Optimised traverse
- Powerful milling spindle for high processing speeds
- Up to 500 m³/h vacuum power for the processing of small pieces

Comfort

- Automatic length measurement system
- Suggestion for optimal vacuum field selection
- The laser safety system makes 4 sided loading a possibility
- Centralised extraction hood

Flexible

- Individual vacuum configurations
- Numerous tooling positions
- 6/8 independent vacuum fields
- Milling spindle can be adjusted between 1.000 and 24.000 rpm
- Drilling head can be adjusted between 1.000 and 6.000 rpm

Quality

- Gantry drive with dual sided servomotors
- Milling spindle with HSK F63 tool clamping system (professional)
- Ground and hardened guides
- Engineering quality from Austria
- High quality, solid machine components
- Automatic central lubrication ensures low maintenance

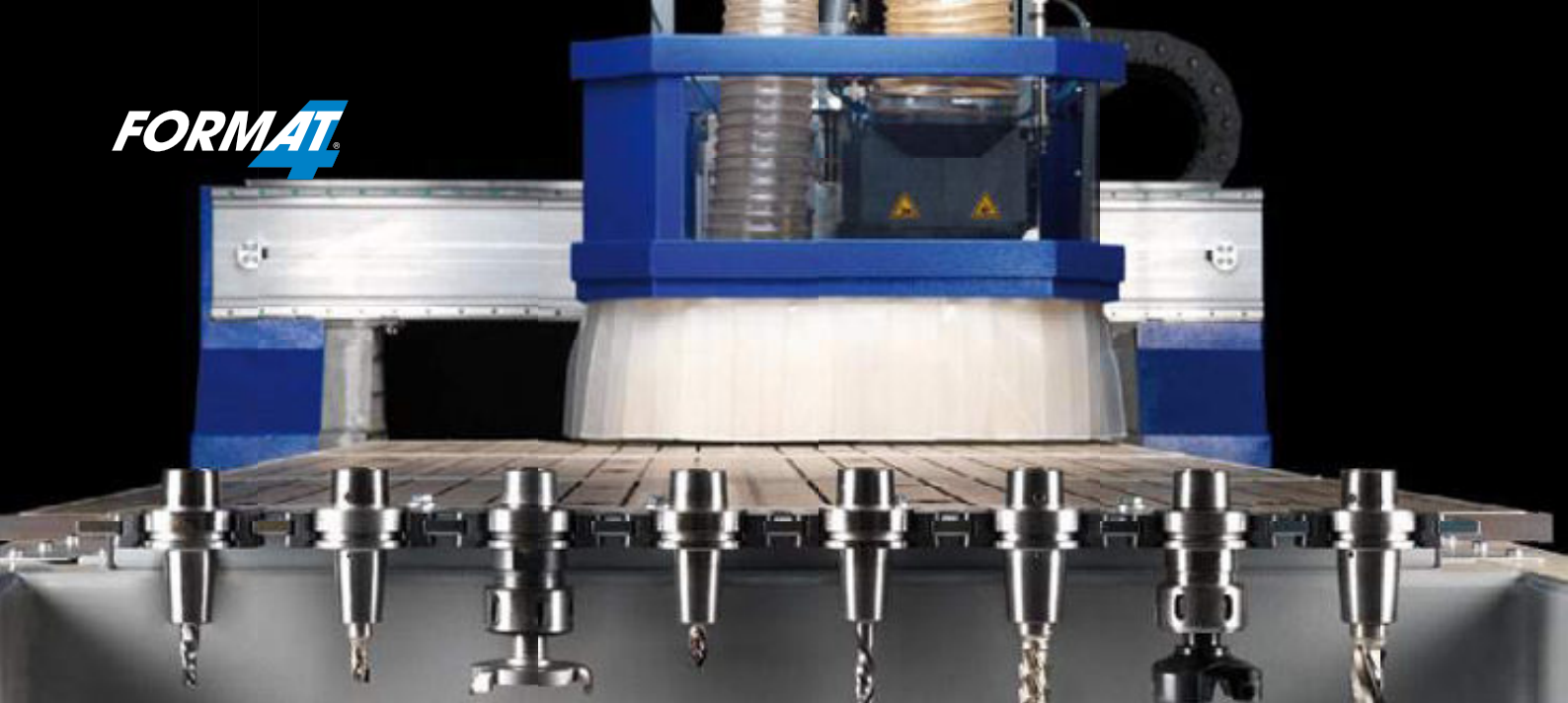

Working area

Milling and drilling - in any desired shape -
in a single working process

The dual side driven gantry on the profit H08 guarantees maximum precision and repeatability.

Perfect nesting with the FORMAT-4 matrix table

The matrix table with optimised grid geometry allows the full surface support of workpieces of all designs and sizes and guarantees their exact positioning. Reference fences mounted directly to the table offer additional support when optimising off-cuts and can be optionally monitored with collision prevention sensors.



Vacuum fields

Vacuum fields individually selectable using rotary valves guarantee a perfect vacuum for various materials and workpiece sizes.



Hand-held terminal

Hand-held terminal with potentiometer and emergency stop.



Gantry system

The rack and pinion drive in the X and Y direction ensures for maximum traverse speeds for the shortest processing times and tool changing times.

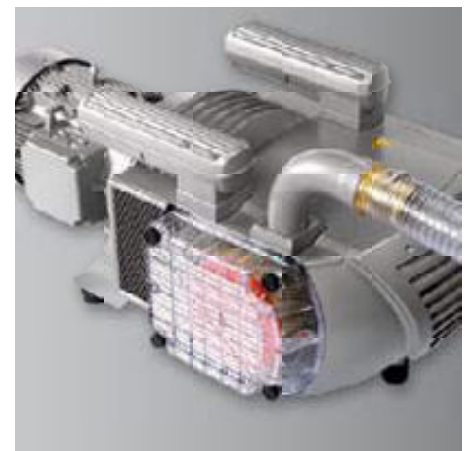

Vacuum system

250 m³/h or 500 m³/h instead of 180 m³/h.

Working area, traverses distances

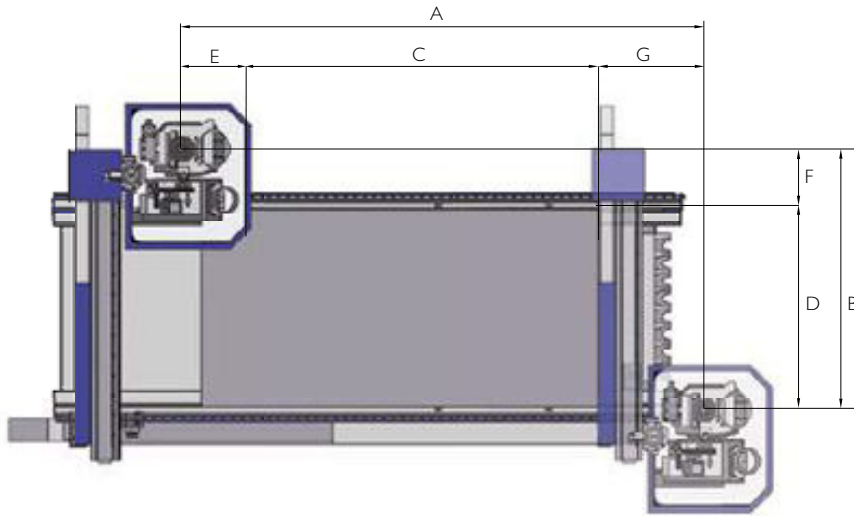

profit H08 13.25

- A 3260 mm
- B 1630 mm
- C 2500 mm
- D 1250 mm
- E 593 mm
- F 186 mm
- G 166 mm

profit H08 16.32

- A 3860 mm
- B 1930 mm
- C 3090 mm
- D 1530 mm
- E 593 mm
- F 186 mm
- G 176 mm

Drilling head



The drilling head

- DH 8 drilling head, with 8 vertical spindles
- DH 12 drilling head, with 12 vertical spindles
- Inverter driven motor up to 6.000 rpm

The machine carries out vertical drilling.

DH 8



DH 8



DH 12



Spindle



“Professional” for maximum productivity and complete flexibility

In the Professional package the high performance milling spindle has an HSK-F63 tool holder which together with a 10 kW motor power and 24.000 rpm, delivers perfect results even when processing difficult to work materials. Up to 10 tool positions ensure quick tool changing times and make the H08 even more profitable.

Equipment package “start” for perfect milling results

The high-performance milling spindle in the 'start' package with ER 32 collet chuck, 10 kW motor and 24.000 rpm achieves first-class cutting results and maximum precision with maximum productivity.

Automatic measuring system of the tool length

Setting the parameters of your tools made easy: every tool length is stored in the tool database accurately to one hundredth of a millimetre.

Tooling positions and space requirement

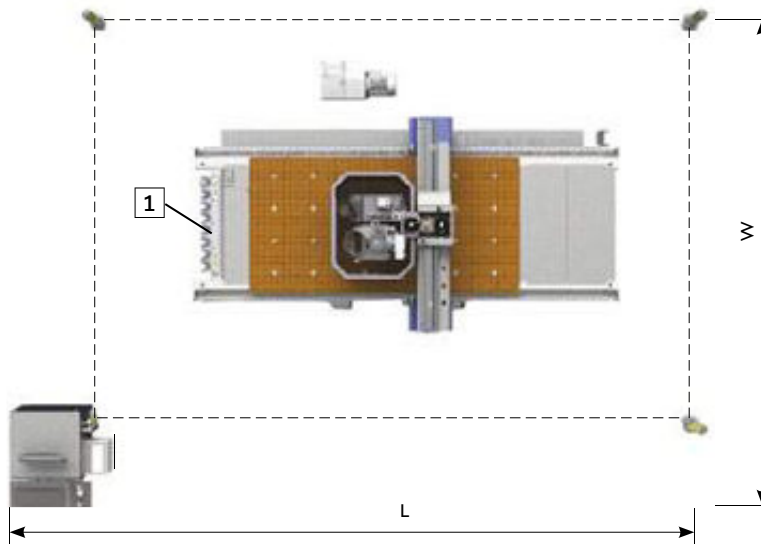

Symbolic image, profit H08 13.25, profit H08 16.32



Tool changer
8- or 10 position tool changer on the side of machine chassis

| | profit H08 13.25 | profit H08 16.32 |
|------------|------------------|------------------|
| Height [H] | 1650 mm | 1650 mm |
| Length [L] | 5800 mm | 6200 mm |
| Width [W] | 3790 mm | 4090 mm |

Dimensions given can vary if special equipment is used

Vacuum pods

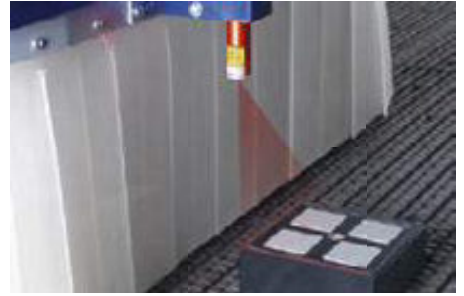
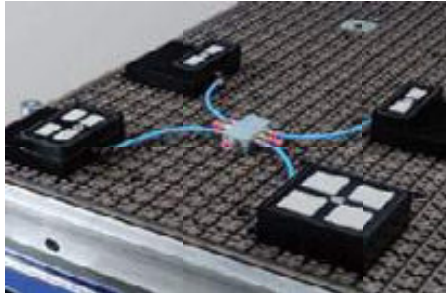

Quick and easy positioning of the vacuum pods, suitable for every workpiece size
 The matrix geometry of the matrix table makes handling and positioning the vacuum pods easy. Additionally a distributor can be used, to establish a dual-circuit vacuum system.

Vacuum pods - positioned quickly
 The hand-held terminal activates and positions the cross laser.



Vacuum blocks for the matrix table

| POS | Description | L x W x H |
|-----|--|----------------|
| 1 | Distribution plate | |
| 2 | Vacuum suction pad for MT slotted table, hose-free | 126 x 126 x 40 |
| 3 | Vacuum suction pad for MT slotted table, hose-free | 126 x 75 x 40 |
| 4 | Vacuum suction pad for MT slotted table, hose-free | 126 x 50 x 40 |
| 5 | Vacuum suction pad for MT slotted table, hose-free | 126 x 30 |
| 6 | Elbow joint for the adaptor connection | |

Application examples profit H08/H10



Engraving



Edge processing



Screw taps

Application examples profit H10

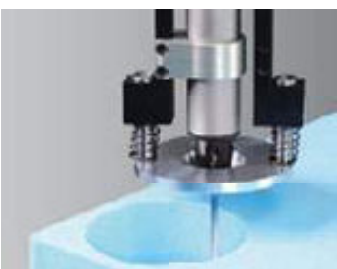

Cutting foam



Lamello



Doors

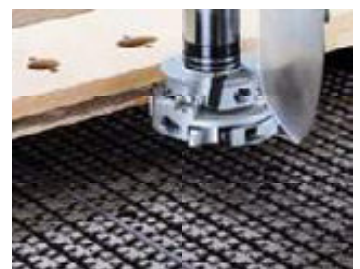

Chip deflector

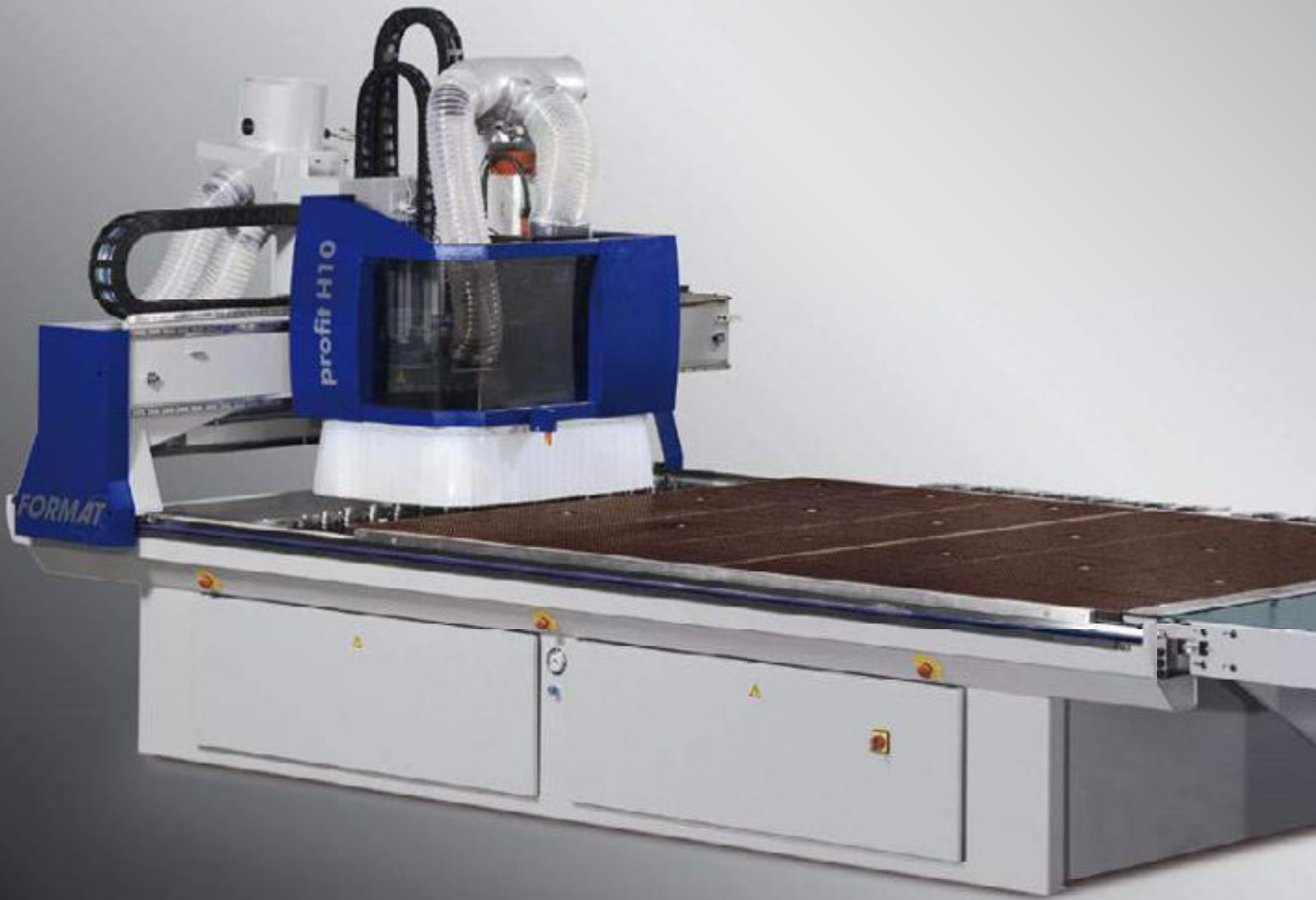

profit H10

Efficiency in single person operation

The profit H10 panel formatting, drilling and milling centre brings a whole new level of efficiency to single person operation. In just one working process the CNC machining centre carries out formatting, drilling and nesting, guaranteeing maximum workpiece usage and minimum waste. The highly precise edge finish ensures that the workpiece can go on to the next stage of production without any post processing being required.

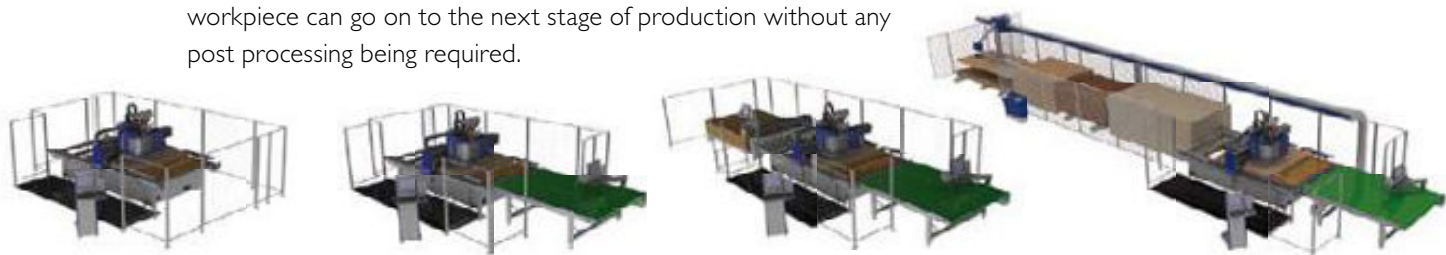

The machine illustrations may show optional equipment. Please refer to your individual quote for clarification on which options are included.



Time saved

- CNC cutting, milling, drilling and nesting in one work process
- Traverse speed of up to 140 m/min of the \overline{XY} axes
- Rack and pinion drive ensuring maximum processing speeds
- Automatisation with loading and unloading units
- Automatic label printing on the unloading unit
- Up to 750 m³/h vacuum power for the processing of small workpieces

Comfort

- Automatic, software controlled vacuum system
- Automatic length measurement system
- Mobile control terminal
- Automatic cleaning of the spoil board and of the finished workpiece

Flexibile

- Moving vacuum fields ensuring maximum suction on the workpiece
- Use of aggregates and 5 motion^{plus} aggregate system
- Use of vacuum pods
- Up to 36 tool slots
- Chip deflector can be used
- Drilling head for the complete processing

Quality

- Milling spindle with HSK F63 tool clamping system (Standard)
- perfect processing results guaranteed by the gantry system
- Engineering quality from Austria
- High quality, solid machine components
- Automatic central lubrication ensures low maintenance

Working area



Panel cutting, drilling and milling in any shape desired, all in one process!

CNC Cutting

- Load panel, start working.
Once loaded, the profit H10 works without an operator: No additional programming is required.

CNC Drilling

- Material does not need to be processed further by a CNC or drilling machine.
- Significant time savings thanks to a combination of CNC cutting and CNC drilling in just one work cycle.

CNC Milling

- Matrix table can be fitted with vacuum pods; CNC milling operations can be carried out just as in standard CNC machines.

The two-sided driven portal design of the profit H10 guarantees the highest precision and repeatability of your processing. The rack and pinion drive in the X and Y direction ensures for maximum movement speeds for the shortest processing and tool changing times.

CNC Nesting

- Any desired shape can be used.
Minimum waste thanks to nesting software.
- Significant time savings thanks to a combination of CNC cutting, CNC drilling and CNC nesting in just one working cycle.

Working area, traverse distances

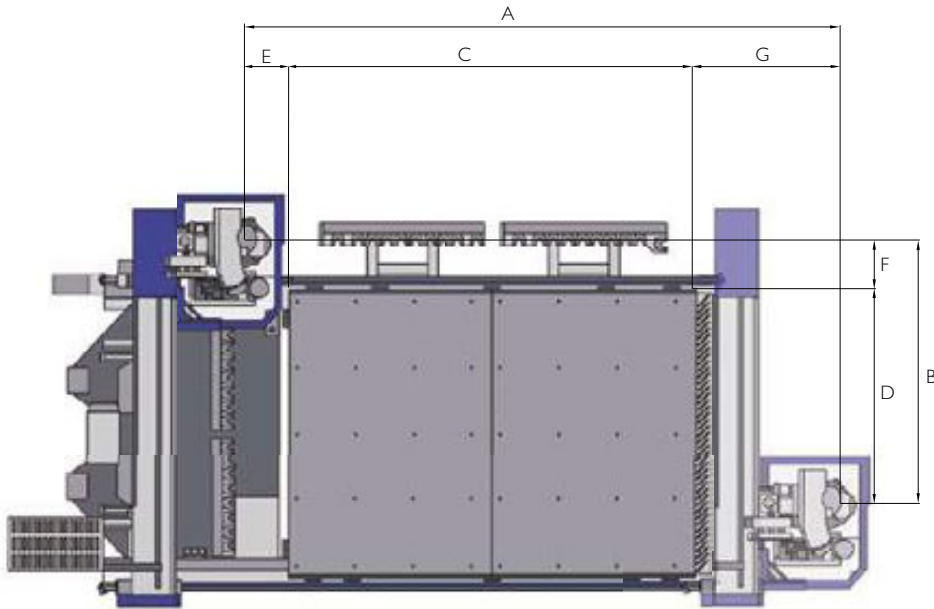

profit H10 22.32

- A 4050 mm
- B 2560 mm
- C 3120 mm
- D 2160 mm
- E 448 mm
- F 375 mm
- G 482 mm

profit H10 22.43

- A 5250 mm
- B 2560 mm
- C 4320 mm
- D 2160 mm
- E 448 mm
- F 375 mm
- G 482 mm

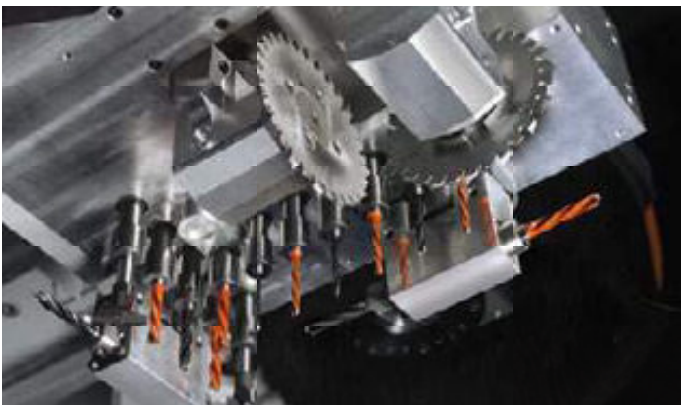

The drilling head

Regardless whether the machine will only be used for cabinet manufacturing or as an all-rounder. You decide which drill-head configuration is the right one for you. Choose between, a head with only vertical drilling spindles or spindles with a grooving saw for vertical and horizontal processing. Inverter driven motor up to 7.500 rpm.



DH 12



DH 16 4H 2S

Main spindle

With a motor power of 12 to 15 kW with up to 24.000 rpm and inverter controlled, the motor is more than capable to tackle any task. The motor is fixed directly on to the carrier unit in the Z-axis. The highly precise vertical guiding of the motor is guaranteed by two vertical guide tracks. The HSK F63 tool clamping takes place automatically. The tension of the tool is controlled by sensors and the operation safety confirmed. The tooling housing is cleaned pneumatically. The C-axis is available as the standard fourth axis and is interpolating (360°) with a compressed air interface for the units.



Automatic measuring system of the tool length

Setting the parameters of your tools made easy: every tool length is stored in the tool database accurately to one hundredth of a millimetre.

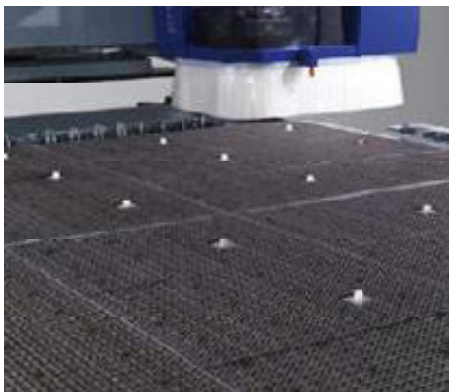

Loading supports

The distribution of the loading supports assist in the loading of the spoil board.

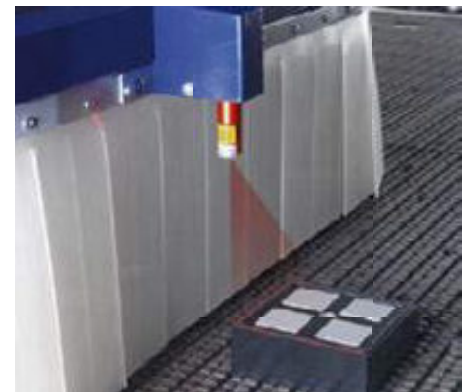

Vacuum cups - Positioned quickly

The hand-held terminal activates and positions the cross laser.

Tooling positions and space requirements

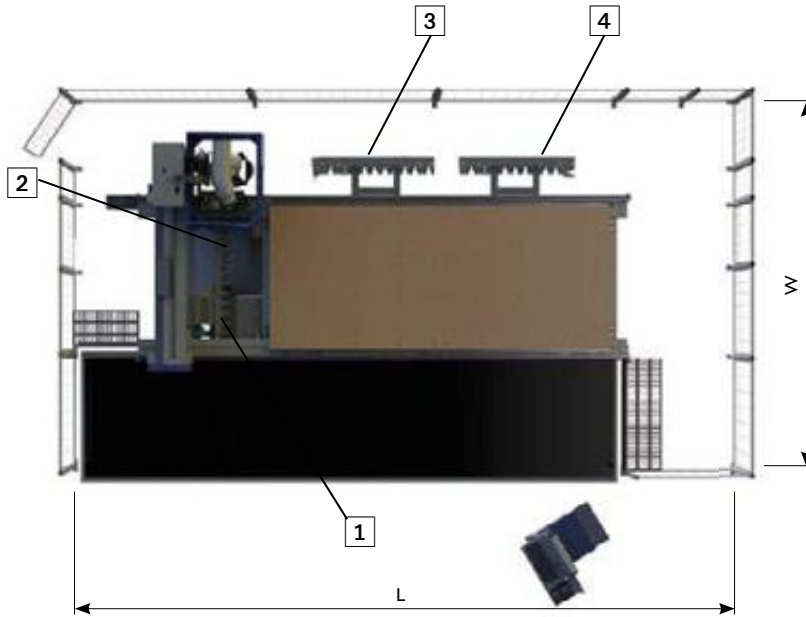

Symbolic image profit H10

| | profit H10 22.32 | profit H10 22.43 |
|------------|------------------|------------------|
| Height [H] | 2510 mm | 2510 mm |
| Length [L] | 6800 mm | 8000 mm |
| Width [W] | 4750 mm | 4750 mm |



1 8 position linear tool changer
on the side of the machine chassis.



2 8 position linear tool changer
on the side of the machine chassis.



3 10 position linear tool changer
at the rear of the machine chassis.



4 10 position linear tool changer
at the rear of the machine chassis.

CNC-Aggregates

Tool changer

The linear tool changer ensures a rapid tool change and minimises the compressed air consumption. This enables the use of aggregates that have larger tool diameters for increased performance of your profit H10. Up to 36 tool and aggregate positions are available.



5-motion/5-motion^{plus}

Automatically fully adjustable!

With the 5-motion/5-motion^{plus} tilting aggregate your CNC machining centre becomes a 4 1/2 axes machine.

HSK F63 Floating unit with tracer for vertical routing of exact milling depths HSK F63
Order no. 300-24-010



Cut, push-off and label



The integrated unloading unit on the portal pushes the finished workpieces off after processing and cleans the table at the same time. Any remaining chippings are extracted via the under table extractor. During the unloading process, the first label is printed out and the corresponding workpiece is shown in colour on the the screen, indicating to which workpiece it belongs. This process is then repeated workpiece for workpiece.



Fence options

As an option, fences can be mounted either at the front left or right hand side of the machine. This guarantees maximum user comfort and additional flexibility when processing various sized workpieces. On automatic machines the continuous fence ensures a steady off feed on to the conveyor belt.

Drawing = programming

As a beginner and after just four days of training, you will be able to program your FORMAT-4 CNC-machining centre ready for every application

The Format-4 programming software is of significant support to the high flexibility and fast operational times of your CNC machining centres.

The software enables fast and profitable machining of any single workpiece, regardless of how simple or complicated. The Format-4 programming software has numerous functions, is incredibly advanced yet self-explanatory.



GLOBAL REACH
FORMAT-4 SOFTWARE

Woodflash

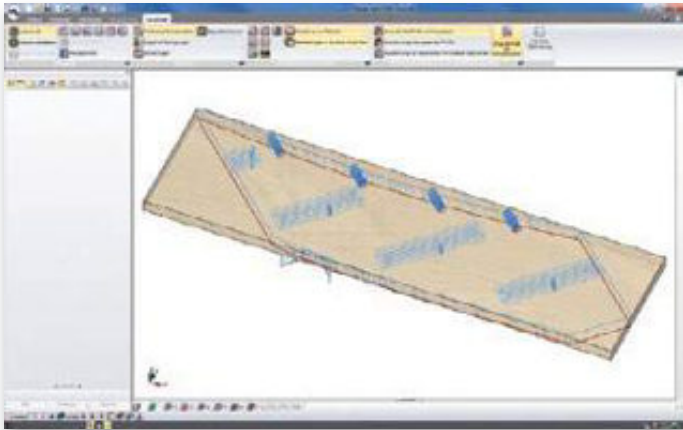

CNC-Editor: Profit from the first minute

With Format-4, CNC comfort already starts at the planning phase. Save time and money with every work process.

- Programming of each component to its final size
- DXF-Import as a standard solution
- Variable programming, quick and simple
- Simple administration of subprograms
- A variety of macros facilitate the programming, even with complex design workpieces



2D simulator

Fast calculation of machining times



Tool parameters

Tool database: Diameter, length, speed, feed rate, etc.



Equipment parameters

Managing the machine tools

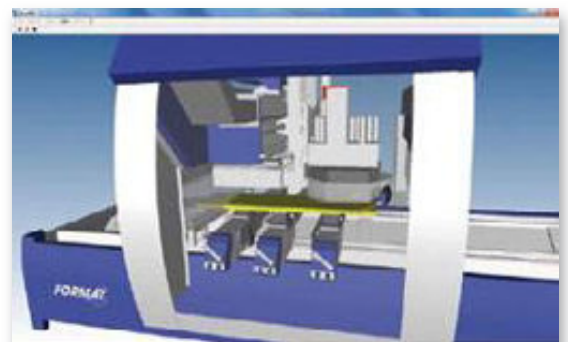

3D-Simulator

Optional: Accurate representation of your machine as a 3D model incl. collision control



Every aspect under control with the CAD “Flash 3D” software from FORMAT-4

Planning, presenting, constructing, calculating, transferring CNC programs, the cabinet software enables the planing and construction of furniture in a whole new dimension. By entering just a few parameters, individual case furniture designs can be created in minutes with maximum professionalism whilst discussing the plans with the customer. The data for the production including CNC programs can be generated automatically. A material/piece list with the image of the unit will be generated automatically.

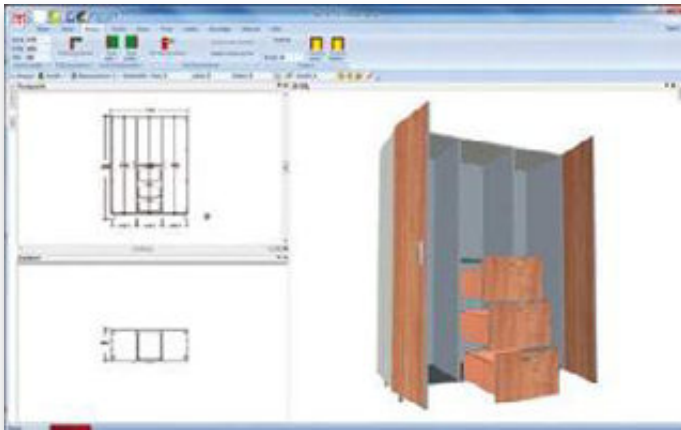

Flash3D Basic/standard Version

With the standard version of Flash 3D a single cabinet can be designed and displayed as a 3D image in a room. Using predefined fittings the cabinet design can be amended with ease.



Flash3D Professional Version

Flash 3D Professional enables the simple planning of several cabinets and complete kitchens. Using the kitchen generator, the cabinets can be precisely adapted to fit the space available. The integrated CAD application makes it possible to customise the design to individual room layouts and cabinet components.



Simulator

Fast 2D simulation to calculate the costs of individual building components. If required, it is also possible to have a 3D simulator with collision control.

Additionally Format-4 offers individual export options of CNC programs. Simple export of:

- Automatic mitre cuts - with a "roof pitch" option
- Nesting formatting
- Separation from the horizontal and vertical processing
- Labelling instruction
- Formatting with the chip deflector
- Setting of standard fields

Flash Frame



Every type of window at the click of the mouse.

Only a few parameters are required to plan the frames and infills for your windows and doors. The following parameters can be inputted: size, corner joints with or without glass window bars, fittings etc. A mouse click suffices to separate the window into individual CNC programs in a matter of seconds.

The machine operator can retrieve these files from the machining preparations and complete the work without having to modify the programs. A list of materials is generated automatically with a diagram of the window.

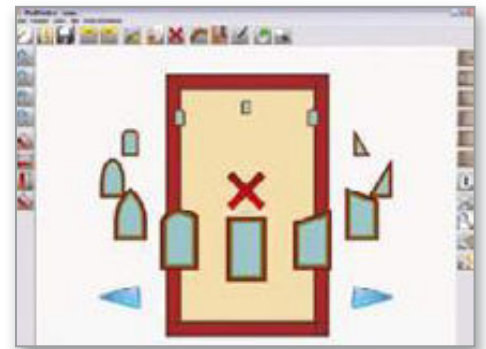

Reversible rebating head

- Directly from Flash Frame
- No postprocessing
- For every thickness
- Regardless of the rung width

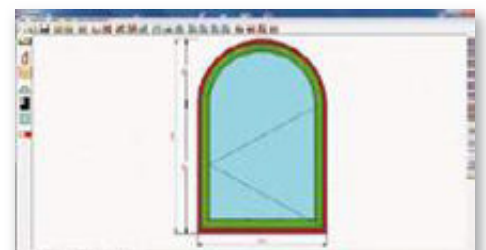
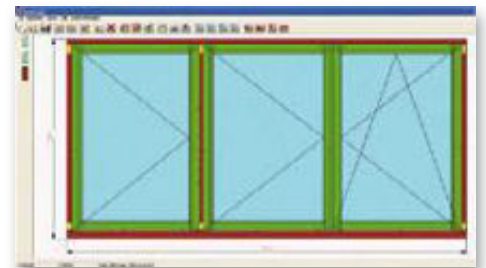
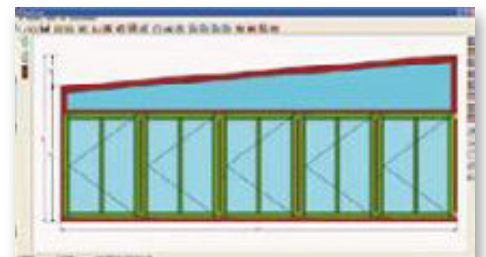
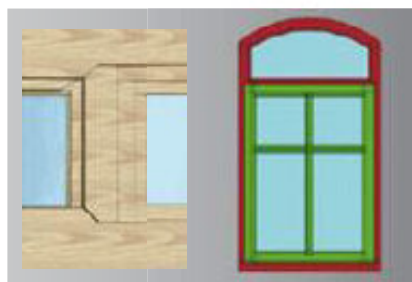



FlashNest - Optimisation software for nesting

Planning, drawing, constructing, transferring CNC programs

The Format-4 programming software is intuitive and self-explanatory software, a result of the latest generation of programming. The CAD functions enable the user to plan, construct and to visualise the programmed workpiece in 3D. Architects and planning companies will, with their branch specific software, be able to import .dxf file formats.

Material saving shape processing: Nesting with "FlashNest"

Processing of shapes such as the milling out of upholstered furniture components, is known as nesting. The matrix table holds the whole surface of the workpiece in place, "FlashNest" the Format-4 nesting software calculates the maximum possible number of shapes that can be optimally milled from the workpiece format.

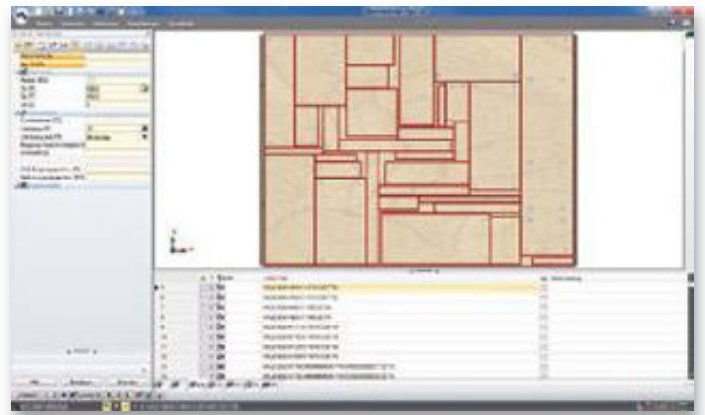

FlashNest Professional connection to the warehousing system

FlashNest enables the automatic link to Format-4 warehousing systems. Using Flash3D, material information about the cabinet construction is passed on, which with the help of FlashNest and warehousing database can be compared and separately nested. The automatic warehousing command improves eases the management of waste material. Alternatively, a local database can be created and managed, or external cutting lists after the Excel import can be optimised.

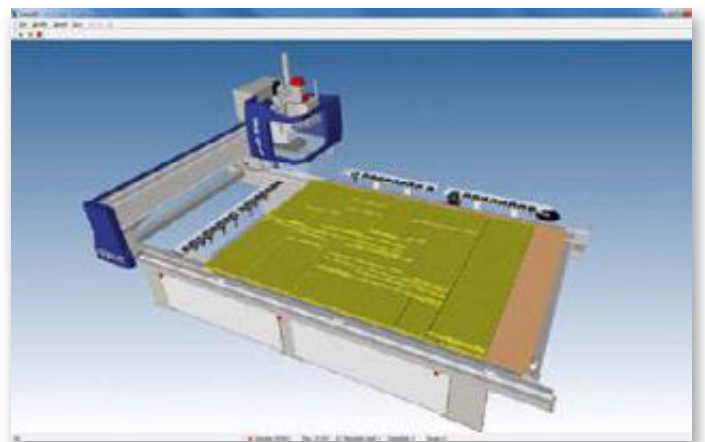

3D simulator with collision control

The 3D simulator enables accurate machining times to be calculated and an exact representation of travel distances, feed rate speeds, overtravel heights and optional equipment such as the 5-motion unit, chip deflectors, rotary tool changer and drilling head.

The collision control function checks whether collisions could occur and thus guarantees safe machining.

Due to the allocation of a DXF profile by the tool, it is possible to position the moulder contour onto your workpiece. The DXF profile can be used as a further help when bringing in new tools which results in less material usage.

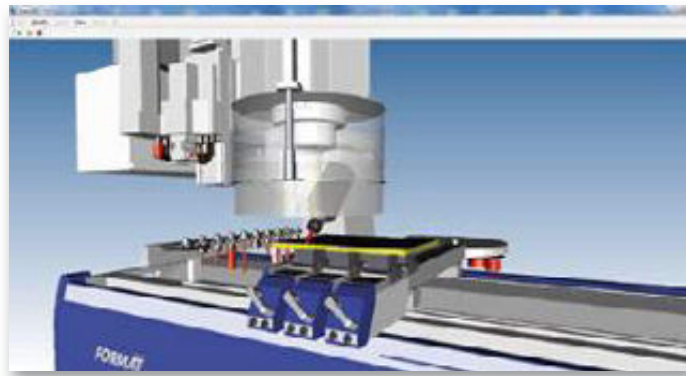
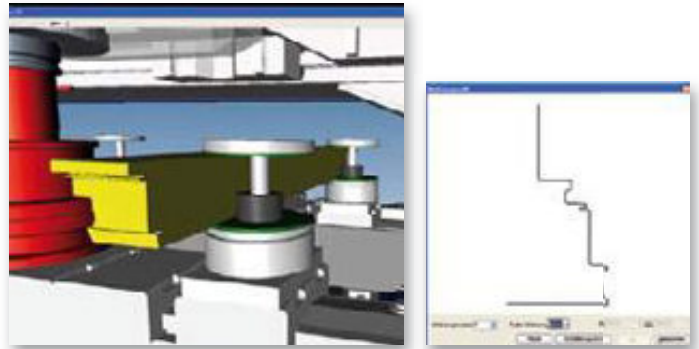

5 axes programming, quick and simple!

With the easy to program Format-4 software, end milling cutters can also be used for bevelling. Get the most from your 5 axes machine and reduce your tooling costs.

Woodflash module: Extruded surfaces with engraving and projection function

The milling in surface I is generated using the predefined contour in the surface to the side. Pockets, free contours or DXF imports make it quick and easy to be able to project or engrave on to the milled surface. The defined tool moves precisely at a right angle to the side of the predefined contour. (option C31 is required)

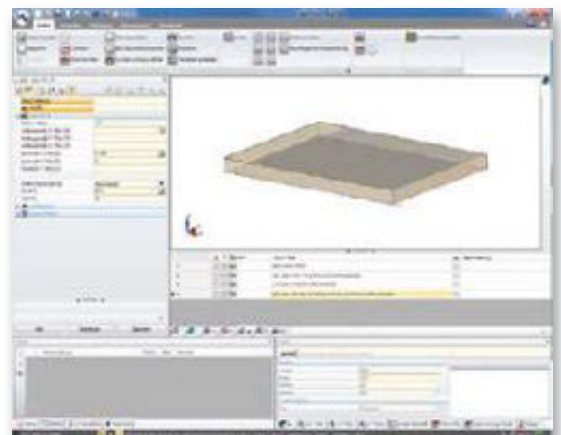
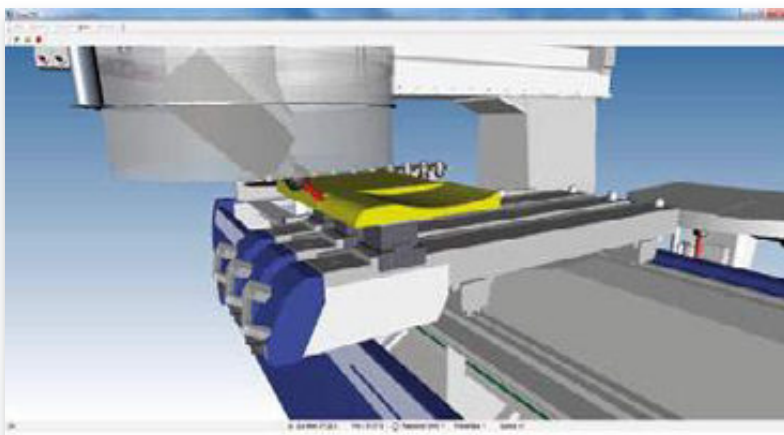



perfect 608/710/812

Uncompromising expertise for the highest of requirements

“Premium” edgebanders

perfect 608, perfect 710 and perfect 812

Productivity, versatility and precision in one!

Regardless of whether you are using coiled or strip materials, the new Format-4 “perfect” models deliver extremely impressive results.

The solid machine chassis and heavy duty units combined with an attractive design ensure the highest level of precision. An absolute highlight of every “perfect” model is the accuracy of the position settings of the individual units. The “e-motion” is quipped with individual machining programs that can be stored and reused, ensuring precise results especially when you require a quick change of material or edging.

A wide choice of optional units are available, to enable you to perfectly adapt your machine to your production requirements.



The most up-to-date edge processing with FORMAT-4 technology

- Thin edges
- ABS and PVC edging
- High gloss workpieces with high gloss edging
- Wood Veneer edging
- Solid wood edging
- Chipboards
- Decorative chipboards
- Wood panels
- Postforming
- Softforming
- and much more ...

The Format-4 edgebander provides a wide field of operation, high performance, flexibility and precise results!

The machine illustrations may show optional equipment. Please refer to your individual quote for clarification on which options are included.



Extremely compact - Extremely effective

High quality premium aggregates: Affordable “invisible-joint” and complete machining of edges for every workshop



perfect 608 x-motion plus

- Premilling unit incl. diamond cutters
- Max. 45 mm corner rounding unit capacity (Option)
- Edge thickness 0,4–8 mm
- Workpiece height 8–60 mm
- 12 m/min feed speed
- Motor-driven multifunctional trimming unit
- The operator can adjust the multifunctional trimming unit accurately within a range of 1/100th of a millimetre from the control panel
- Control panel with 10.4" colour touch screen
- Unlimited storage space for work programmes
- Glue application unit to process EVA and PUR adhesives

perfect 710 x-motion

- Premilling unit incl. diamond cutters
- Max. 60 mm corner rounding unit capacity (Option)
- Edging thickness 0.4 to 10.0 mm
- Workpiece height 8–60 mm
- 12 m/min feed speed
- Manual unit adjustment
- Control panel with 5.7" colour touch screen
- Glue application unit to process EVA and PUR adhesives
- Part automation possible

Option: x-motion-plus Package
 + 10.4" colour touchscreen
 + Unlimited storage space for work programmes
 + Motor-driven multifunctional trimming unit

perfect 710 e-motion

- Premilling unit incl. diamond cutters
- Max. 60 mm corner rounding unit capacity (Option)
- Edging thickness 0.4 to 10.0 mm
- Workpiece height 8–60 mm
- 12 m/min feed speed
- Electronically positionable units
- Fine adjustment of the units to 1/100 mm from the control panel
- Control panel with 10.4" colour touch screen
- Unlimited storage space for work programmes
- Glue application unit to process EVA and PUR adhesives



perfect 812 x-motion plus

- Premilling unit incl. diamond cutters
- Two motor corner rounding unit for Max. 60 mm
- Edge thickness 0.4–12 mm
- Workpiece height 8–60 mm
- 12 m/min feed speed (Option 20 m/min)
- Motor driver multi-functional trimming & corner rounding unit
- Semi-motorised adjustment of the radius scrapers
- Control panel with 10.4" colour touch screen
- Unlimited storage space for work programmes
- Glue application unit to machine EVA and PUR adhesives



perfect 812 e-motion

- Premilling unit incl. diamond cutters
- Two motor corner rounding unit for Max. 60 mm
- Edge thickness 0.4–12 mm
- Workpiece height 8–60 mm
- 12 m/min feed speed (Option 20 m/min)
- Electronically positionable units
- Fine adjustment of the units to 1/100 mm from the control panel
- Control panel with 10.4" colour touch screen
- Unlimited storage space for work programmes
- Glue application unit to machine EVA and PUR adhesives

| MODEL | CONTROL SYSTEM | ALL UNITS AT A GLANCE! |
|---|---|---|
| <p>perfect 608 x-motion-plus</p>  |  <p>Control panel with 10.4" colour touch screen</p> | <p>STANDARD UNITS - perfect 608 x-motion plus</p> <p>Premilling unit incl. diamond cutters</p> <p>Glue application unit with quick change glue pot</p> <p>Edging feed for coiled and strip material</p> <p>Guillotine shears - Pneumatic trim up to 60 mm in height</p> <p>Heavy pressure unit with 3 contact rollers</p>  |
| | | <p>OPTIONS</p> <p>Spraying equipment release agent for PUR glue</p> <p>Infrared heater lamp</p>  |
| <p>perfect 710 x-motion</p>  |  <p>Control panel with 5.7" colour touch screen</p> | <p>STANDARD UNITS - perfect 710 x-motion and e-motion</p> <p>Premilling unit incl. diamond cutters</p> <p>Glue application unit with quick change glue pot</p> <p>Edging feed for coiled and strip material</p> <p>Guillotine shears - Pneumatic trim up to 60 mm in height</p> <p>Heavy pressure unit with 3 contact rollers</p>  |
| | | <p>OPTIONS</p> <p>Spraying equipment release agent for PUR glue</p> <p>Infrared heater lamp</p>  |
| <p>perfect 812 x-motion plus</p>  |  <p>Control panel with 10.4" colour touch screen</p> | <p>STANDARD UNITS - perfect 812 x-motion and e-motion</p> <p>Premilling unit incl. diamond cutters</p> <p>Infrared heater lamp</p> <p>Glue application unit with quick change glue pot</p> <p>Edging feed for coiled and strip material</p> <p>Guillotine shears - Pneumatic trim up to 60 mm in height</p>  |
| | | <p>OPTIONS</p> <p>Spraying equipment release agent for PUR glue</p>  |

MACHINE LENGTH 4200 mm

End trimming unit with 2 independant saw units

Multifunctional trimming unit

Radius scraping unit

Buffing unit



Corner rounding unit

Flush scraping unit

Spraying equipment for cleaning and polishing agents



MACHINE LENGTH 5140 mm

End trimming unit with 2 independant saw units

Multifunctional trimming unit



Spraying equipment for antistatic coolant agent and lubricant for sensitive edging materials

Corner rounding unit

Radius scraping unit

Flush scraping unit

Spraying equipment for cleaning and polishing agents

Buffing unit

Grooving unit



MACHINE LENGTH 5140 mm

Heavy pressure unit with 3 contact rollers

End trimming unit with 2 independant saw units

Multifunctional trimming unit

Two motor double corner rounding unit

Radius scraping unit

Flush scraping unit

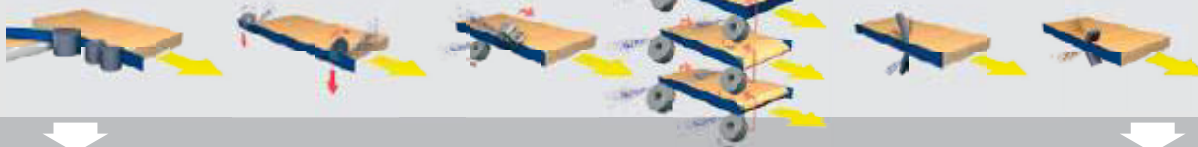

Spraying equipment for antistatic coolant agent and lubricant for sensitive edging materials

Spraying equipment for cleaning and polishing agents

Buffing unit

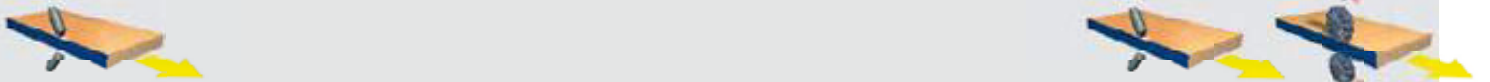

“perfect”-Highlights

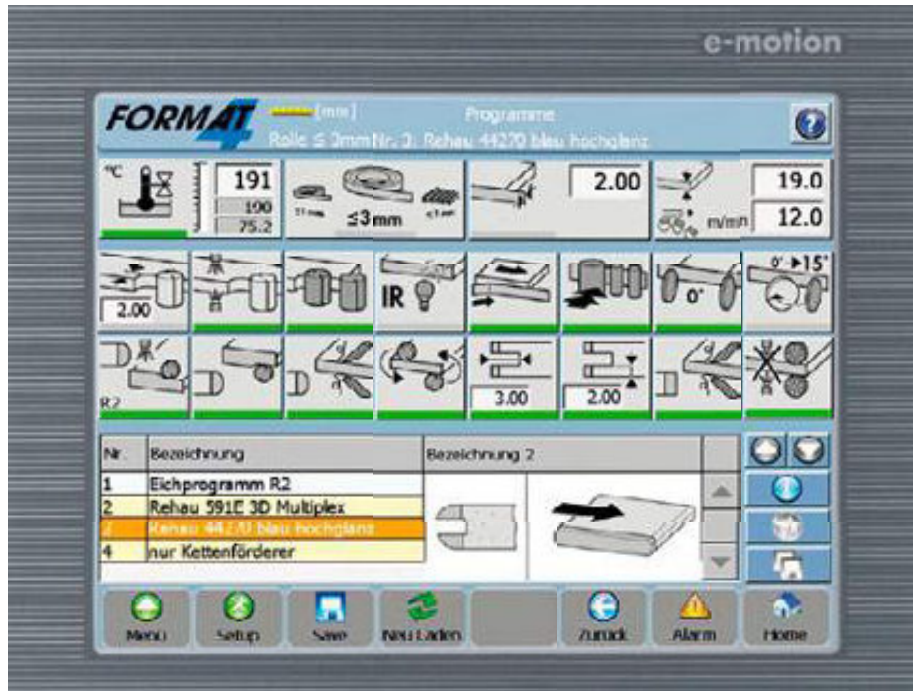

Simple, intuitive control

The self-explanatory symbols and the clear design of the menu on the 10.4" colour touch screen ensures the simple operation of your Format 4 edgebander.

The colour touch screen of the “e-motion” models enable the operator to adjust units with an accuracy of one hundredth of a millimeter. Unlimited storage of working programs facilitate user and customer specific settings and ensures that the machine can be adjusted incredibly quickly.



Request-based user data acquisition

This software package enables individual user administration, including password protection. The number of users is unlimited, with the option of restricted access. In addition, work reports from each user can be individually read, evaluated and calculated in detail.



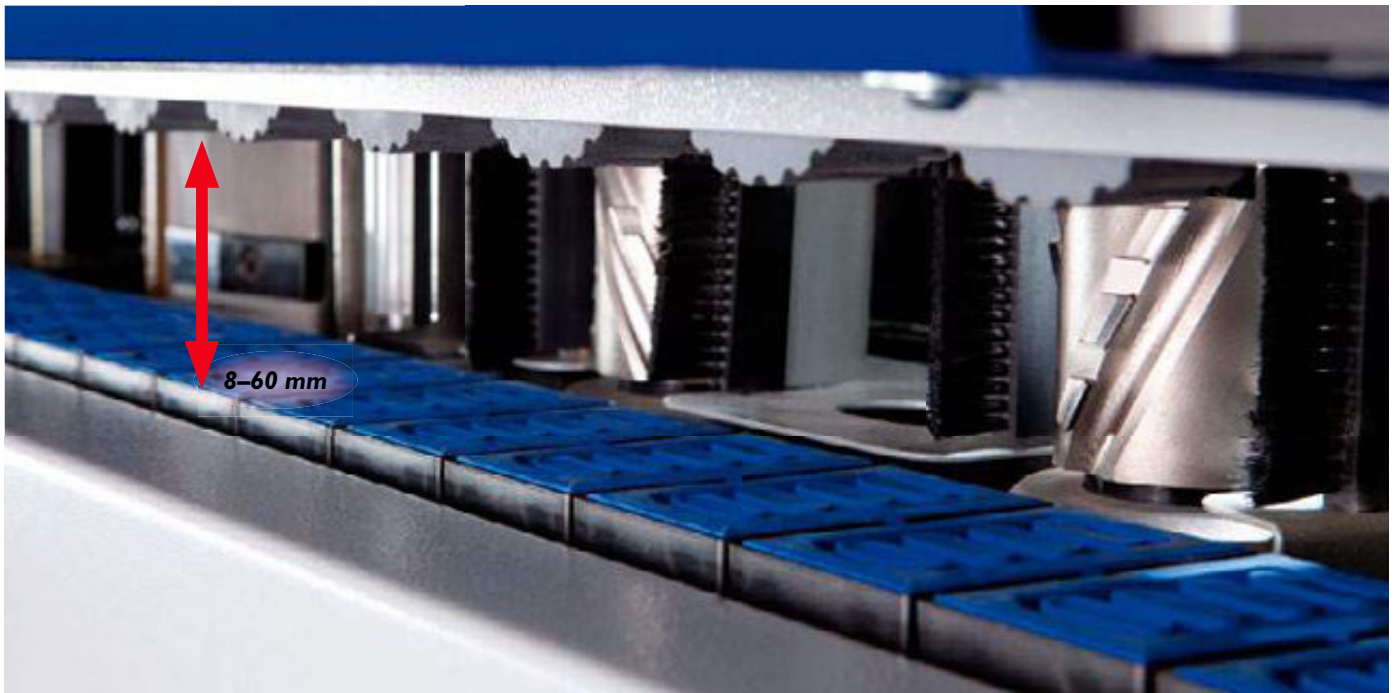

Upper spring-loaded pressure bar

A standard feature of the "e-motion" models is the height setting of the workpiece using the 10.4" colour touch screen using an electric motor. The height needs to be set by hand for the "x-motion" and "x-motion plus" models. The position of the pressure bar can be read accurately from a digital counter.

2 feed speeds for greater productivity

As an option, your edgebander can be equipped to have 2 feed speeds. The feed speed, either 12 m/min or 20 m/min, can easily be selected using the colour touchscreen. This automatically increases the throughput of your edgebander.



Premilling fence

The 10.4" colour touch screen on the "e-motion" models combined with a pre-milling unit allow you to select a depth of cut ranging from 0 to 3 mm. An electric motor positions the fence automatically into the set value. The depth of cut has to be set manually, using the digital counter or the "x-motion" and "x-motion-plus" models.



Spraying equipment release agent for PUR glue

Operation-controlled spray jets apply PUR adhesive separating agents further processing. These agents prevent PUR adhesives from sticking into the workpiece surface resulting in a perfect "finish" without any required.



Premilling unit

The two diamond-tipped milling heads rotate in opposing directions, ensuring a perfectly straight workpiece edge to which the edge material can be glued. The pre-milling unit guarantees that chipped or torn edges are a thing of the past, each and every time. After entering the exact dimensions, the pre-milling unit executes a perfect edge cut on your panels.

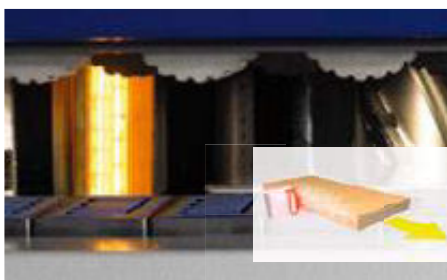

Infrared lamp so the edging bonds better onto cold workpieces

The operation controlled, high quality quartz infrared lamp warms the edge surface in front of the glue unit. This guarantees that the edging adheres to cold workpieces.



Glue application unit

Short heating time, quick change system

The "perfect" edgebander requires only 8 minutes to reach operating temperature. The Teflon coated gluepot and its tool-free quick change system is suitable for EVA (ethylene vinyl acetate copolymers) and PUR (Polyurethane resin) hot melt adhesive granulates. The fine adjustable glue cylinder ensures that the correct amount of the glue required is applied and can adapt perfectly to different edging materials.

Premelting unit for EVA hot melt adhesive

The premelting unit consists of a melting unit with a 4 kg granulate container situated on top of a gluepot (equipped with a liquid level sensor). If the liquid level in the gluepot drops, the controls send a request for additional glue to the granulate container. The requested granulate is pneumatically pressed by the high-performance heated plate, melts and flows into the gluepot.

The new Format-4 premelting unit ensures that there is always fresh, true-colour glue in the gluepot. This helps avoid down time for additional glue warm-up phases.

The granulate container and the gluepot are equipped with a quick-change system as standard. In addition, special cleaning programs facilitate quick glue or glue colour changes.

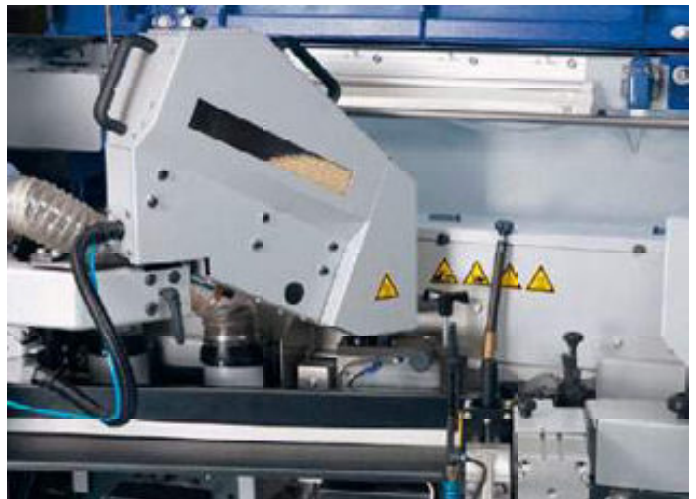

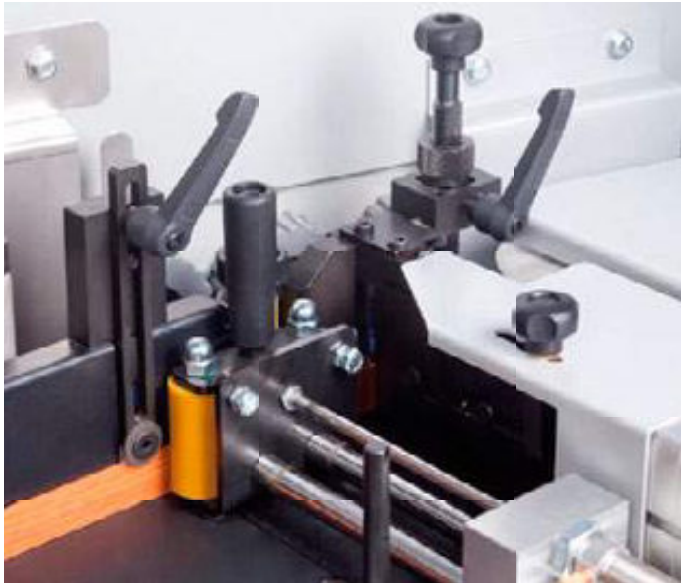

Edge feed and guillotine scissors for coiled and strip material up to 60 mm in height

Depending on the requirement, coiled material 0.4 to 3.0 mm in thickness and strip material up to 12 mm in thickness can be used for workpieces up to 60 mm in height. An infrared sensor recognises whether edging material is available to be processed. The guillotine scissors for cutting the coiled material are set to a maximum of 3x 64 mm.

The magazine, which automatically feeds the strip material via the pin grip roller, has a capacity of 120 mm. The height settings on the pressure bar and the contact pressure manometer placed next to the edge infeed ensure quick changeover times.

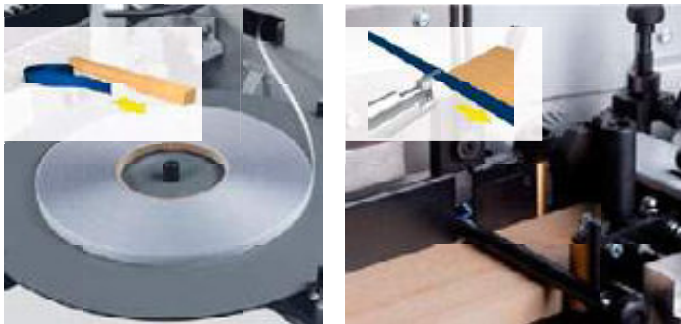

Pressure rollers

Perfectly glued edging

The first pressure roller, which is solid and adjustable, presses the edging material to the workpiece. The adjustable control prevents the glue from smearing and the edging tape from being "squashed". The two conical pressure rollers complete the glue bond at the top and bottom. Two contact pressure settings can be selected from the control panel: less pressure for when strip material is processed and increased pressure for processing coiled material.

Two pneumatic contact pressure settings can be selected from the control panel: a strip cylinder with low pressure and a roller cylinder with high pressure. All e-motion models have an electronically positionable pressure roller unit as standard.





Spraying equipment for the perfect “finish”, leaving a workpiece requiring no further processing

Operation-controlled spray jets to apply antistatic cooling agents or lubricants mean low consumption of these agents. These agents result in cleanly machined edges of sensitive surfaces.

End trimming unit Precise cuts for every application

The end trimming unit consists of two independent saw units with high-frequency motors (12.000 rpm). Linear guides ensure maximum precision. The end trimming unit tilts from 0° to 15°. Depending on the machine specification, tilting is regulated manually or pneumatically via the control panel (e.g. 15° bevel cut, front only, rear only or front and rear).



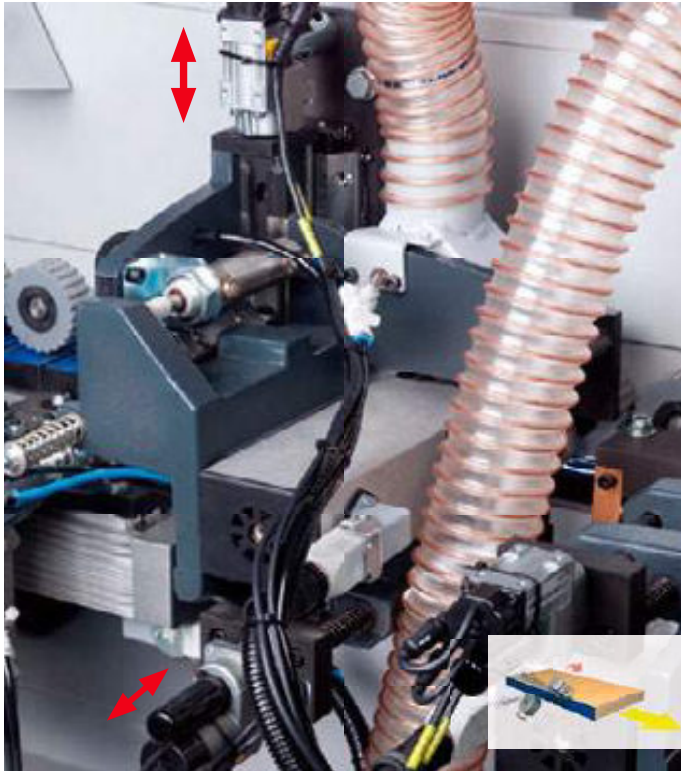

Multi-functional trimming unit

Innovative precision with quick setup

The multi-functional flush, radius and thin-edge bevel trimming unit consists of two independent trimming units with high frequency motors (12.000 rpm). Linear guides guarantee the highest possible precision with little maintenance required. The easy adjustment and setup of the unit means that it is extremely quick to change between different edge thicknesses and profiles. Depending on the equipment option chosen, the multifunctional trimming unit can either be adjusted manually or pneumatically, controlled via the control panel.

The 10.4" colour touch screen on the "e-motion" and "x-motion plus" models enables the operator to set the units for radius, flush and bevel trimming to machine thin edges via an electric motor. This setting is carried out manually using the digital counter for the "x-motion" models.



Horizontal reference rollers

When processing sensitive edging materials, the horizontal reference rollers (instead of a copy shoe) prevent any damage during the edgebanding process.



"Nesting" Package

The "Nesting" Package optimises the processing of workpieces with hinge borings or surfaces with acute angles. The use of several rollers allows the unit to "float" over hinge bores and guarantees a precise processing.

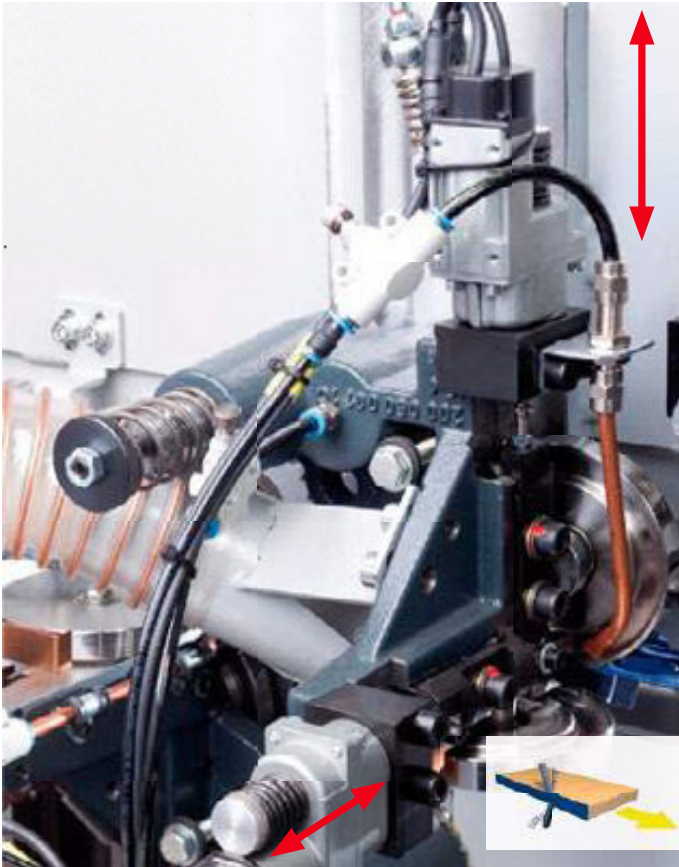

Radius scraping unit

The perfect “finish” - a high quality option

The radius scraper removes marks left by the trimming unit using a slight pulling cut resulting in a smooth finish. The 10.4" colour touch screen on the “e-motion” models enables an accurate setting of the radius scraper unit via an electric motor to one hundredth of a millimeter. This setting is carried out manually, using the digital counter for the “x-motion” and “x-motion-plus” models.

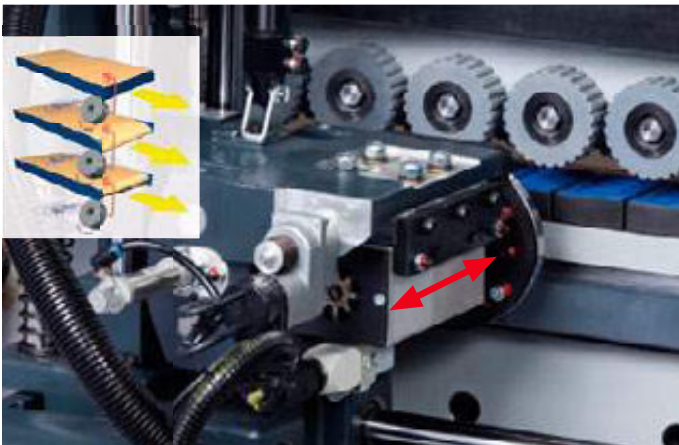

Corner rounding unit

An indispensable option

No more time consuming postprocessing of the workpiece! The Format-4 corner rounding unit finishes workpiece corners (incl. soft forming and post forming materials) for edging materials 0.4 to 3.0 mm thick and up to 60 mm in height, with a feed rate of 12 m/min.

The solid cast iron construction, linear guides and a diamond cutter ensure durable precision. The corner rounding unit is controlled from the control panel, with the choice of which corners need to be rounded (only on the front of the workpiece, only on the back, or both on the front and on the back).

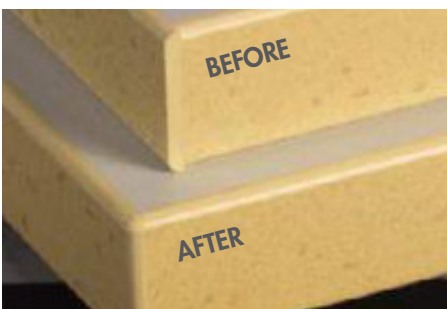

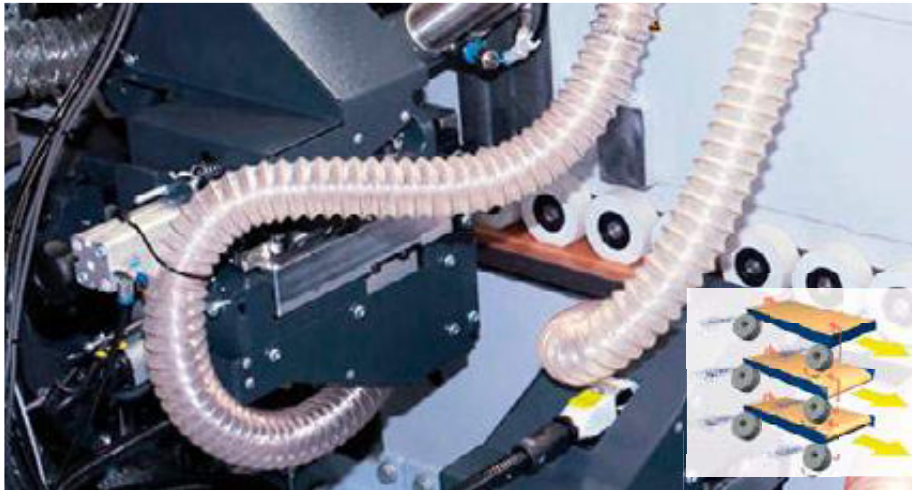

Two motor corner rounding unit

Especially for post and softforming the new perfect 812 with double motor corner rounding unit enables a new dimension in edgeworking. Workpieces with different profiles can be completed in just a single processing step, the need for time consuming subsequent processing is rendered redundant by the perfect finish.

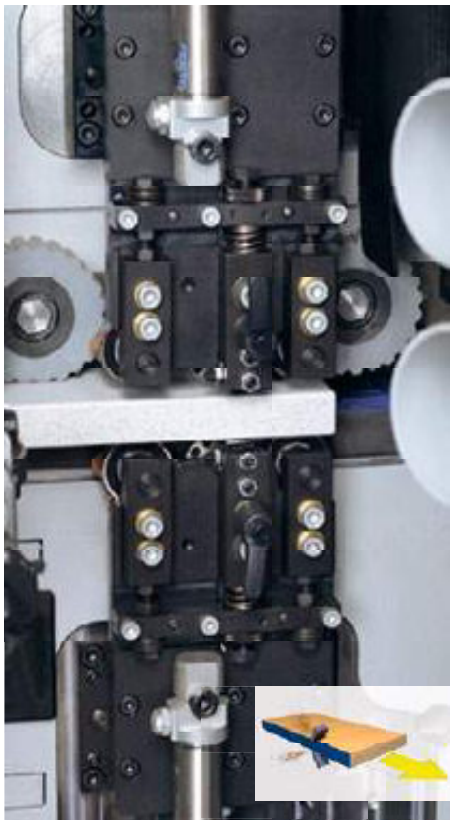

Electronically controlled glue scraping unit

For a perfect surface finish. The light scraping function of the surface scraper knives removes all glue residues from the glue bond on the workpiece surface. One more step towards the perfect and completely finished workpiece. The standard chip extraction system guarantees a high quality of finish.

Grooving unit for horizontal and vertical grooves

The grooving unit in the "perfect 710" ensures even greater productivity. It has a vertical function for back grooves and a horizontal function for tongue-and-groove joints - no need to use a spindle moulder on the workpiece. The type of function, (vertical or horizontal), can be manually set in just a few seconds. The settings for groove position and groove depth (0–15 mm) can easily be selected from the colour touchscreen with a 1/100 mm accuracy. Special grooving saw blades are used according to the desired groove depth (4–7.5 mm)





Buffing unit

The unit is made up of two independent electric motors, which are equipped with cotton brushes. The task of the buffing unit is to clean and polish the top and bottom part of the edge.

The buffing unit gives a super finish for ABS and PVC edging material. The machine can, on request, be equipped with spraying equipment to apply polish onto the workpiece.



Edge gluing using heated compressed air

- Processing of coextruded edge material
- Incredibly quick material changeover
- Up to 12 m/min feed speed with 28 mm edge height
- Universal use of the machine using the gluepot
- Program database for saving varying edge materials

Control Systems

perfect 710/812 e-motion
Control panel with 10.4" colour
touch screen

- User-defined program storage
- Control of the electronically positionable units
- Fine adjustment of the units to 1/100 mm from the control panel
- Easy, self-explanatory representation of the units and their functions
- Glue heating parameter settings (temperature, idle and operating)
- Unit selection
- Selection of the contact pressure of the pressure rollers
- Fine adjustment of the distance parameters
- Setting adjustment of the trimming length of the protruding edges at the front and the back of the workpiece
- Plain text error messages
- Maintenance schedule
- Odometer for total metres of material used
- and much more ...

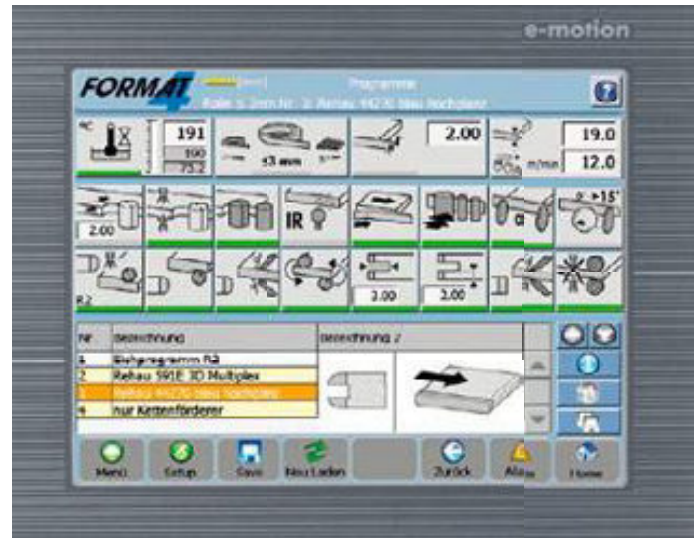

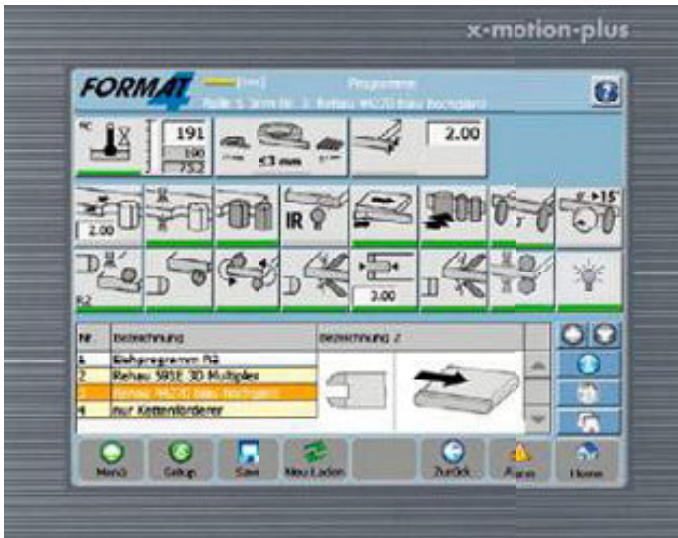

perfect 608/710/812 x-motion-plus Control panel with 10.4" colour touch screen

- Unlimited storage space for user-defined work programmes
- The multifunction spindle moulder unit can be moved with 1/100th mm accuracy (motor-driven movement) using the control panel
- Fine adjustment of the spindle moulder unit with 1/100th mm accuracy using the control panel
- Glue temperature adjustment
- Automatic glue temperature decrease
- Odometer for total metres of material used
- Display of the maintenance intervals
- Plain text error messages
- and much more ...

Automatic positioning for flush and radius trimming or bevelled cuts with an accuracy of 1/100th mm using the control panel and unlimited storage space on a 10.4" colour touchscreen = x-motion-plus



Control Systems

perfect 710 x-motion
Control panel with 5.7" colour touch screen

- 4 operational programs for a quick selection of the materials
- Easy, self-explanatory representation of the units and their functions
- Glue heating parameter settings (temperature, idle and operating)
- Unit selection
- Selection of the contact pressure of the pressure rollers
- Fine adjustment of the distance parameters
- Setting adjustment of the trimming length of the protruding edges at the front and the back of the workpiece
- Plain text error messages
- Maintenance schedule
- Odometer for total metres of material used
- and much more ...



Technical specifications



| | perfect 608 x-motion plus | perfect 710 x-motion | perfect 710 e-motion | perfect 812 x-motion plus | perfect 812 e-motion |
|--|------------------------------|-------------------------|-------------------------|------------------------------|-------------------------|
| Max. workpiece height | 60 | 60 | 60 | 60 | 60 |
| Max. edge thickness | 8 mm | 10 mm | 10 mm | 10 mm | 10 mm |
| Control panel with 10.4" colour touch screen | S | O | S | S | S |
| Manually adjustable pressure bar | S | S | - | S | - |
| Electrically adjustable pressure bar | - | - | S | - | S |
| Infrared heat lamp for pre-heating board edges | O | O | O | S | S |
| Reverse mode for the glue application roller | O | O | O | S | S |
| Working height | 890 mm | 890 mm | 890 mm | 890 mm | 890 mm |
| Length [L] | 4590 mm | 5290 mm | 5290 mm | 5290 mm | 5290 mm |
| Width [W] | 1300 mm | 1300 mm | 1300 mm | 1300 mm | 1300 mm |
| Extraction connection-Ø | 120/160 mm | 120/160 mm | 120/160 mm | 120/160 mm | 120/160 mm |

S ... Standard features O ... Option - ... Not available



Further information about the technical data, individual configuration options and all noise level values can be found on the internet at www.format-4.com

Space requirement

Scale
1:50

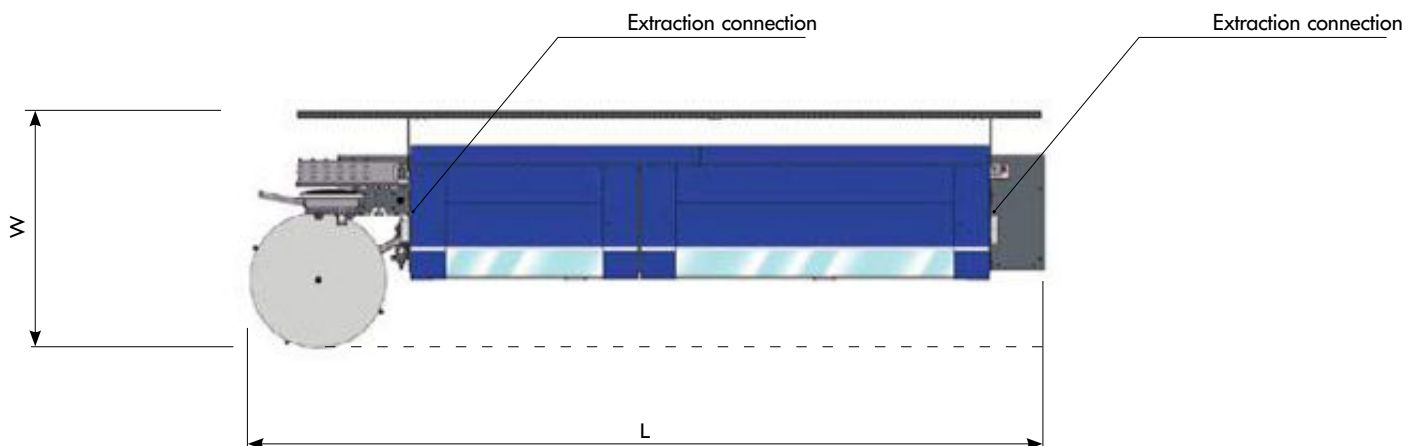

Symbolic image perfect 608 x-motion plus, perfect 710 x-motion, perfect 710 e-motion, perfect 812 x-motion plus, perfect 812 e-motion

Dimensions given can vary if special equipment is used



finish 1102
finish 1302

The only option if you are looking for a better than perfect workpiece finish

Format-4 Wide-Belt Sanding Machines are characterised by their solid construction, modern machine technology and maximum productivity. You can choose: 1100 mm or 1300 mm working width, different sanding units, combination units and lots more. With premium quality, absolute precision and highest user comfort a great finish is guaranteed.



Sanding shoe

Precise calibration work:

Our variable Grit Set system ensures dimensional stability without compromise.

Electropneumatically EP sanding shoe

(for fine and veneer sanding)

The electro-pneumatic sanding shoe (EP) distributes pressure uniformly over the whole surface and adapts itself to the surface. Surface tolerances are balanced out without also having to work the coating.

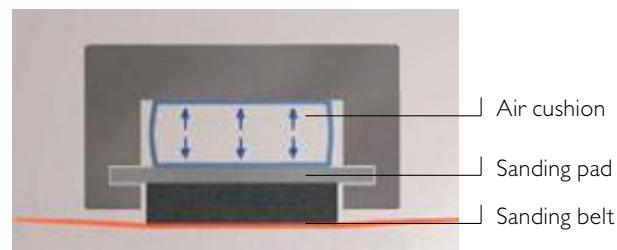

Segmented electro-pneumatic sanding shoe

The segmented electro-pneumatic sanding shoe can be used specially for the lacquer sanding of workpieces with a semi gloss finish and of workpieces with rounded edges or acute angled corners. The ability to select which pressure bars to use and the touch screen control of the entry and exit point enables the exact setting of the area to be sanded. For maximum process accuracy, the parameters can be saved as a program and reused as and when required.



finish 1102

- Sanding width 1100 mm
- Sanding height 170 mm
- Contact roller unit
- Combination aggregate with sanding unit (electro-pneumatic (segmented))

finish 1302

- Sanding width 1300 mm
- Sanding height 170 mm
- Contact roller unit
- Combination aggregate with sanding unit (electro-pneumatic (segmented))

Feeder table

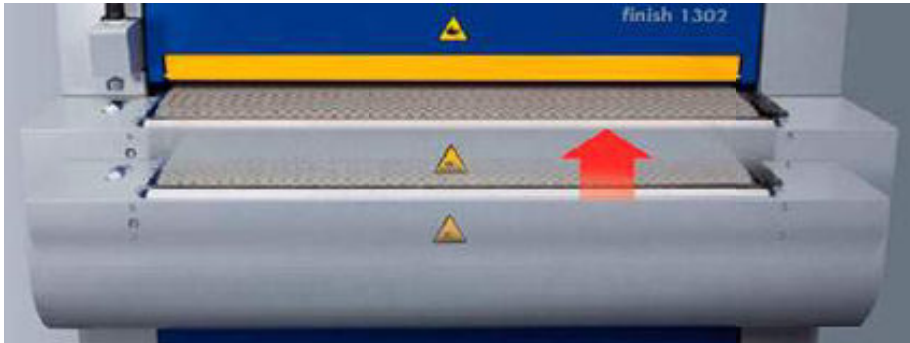

The solid feeding table is fed using over 4 heavy duty feeding spindles, highest stability is guaranteed. The clearance height of 3–170 mm can be finely adjusted to an accuracy to a tenth of a millimetre directly from the control panel. The feeding belt made from natural rubber ensures maximum lifespan.

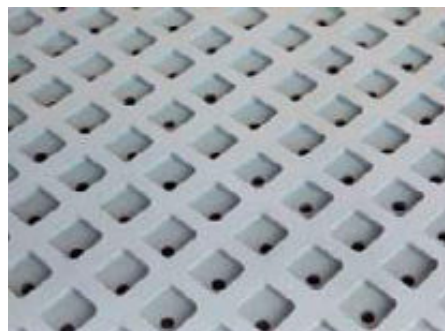

Vacuum table

The optional vacuum table improves the processing of small or smooth surface workpieces to be processed.

Feeder drive adjustable between 2.8 and 20 m/min.

As standard, the feed speed can be continuously adjusted from the control panel between 2.8–20 m/min.

Units

Combination module with sanding shoe

The profiled rubber coated contact roller (optionally in steel) in combination with a sanding shoe guarantees calibration with maximum precision. The flexible grain compensation makes it possible to adjust the roller to match the exact sanding belt grain in use. Depending on the specification chosen, the sanding shoe can be set for fine and veneer sanding or lacquer sanding and adapts itself perfectly to the contours of the workpiece. An optical sensor controls the oscillation of the sanding belt ensuring it remains central and running smoothly.



Pneumatic selection of the contact rollers

Optionally the contact rollers can be activated directly from the control panel.

Contact roller unit

The profiled contact roller (with 85° shore; optionally from steel) guarantees precision without compromise when calibrating.

Control



Control panels I100/I300

The clearly structured and intuitively laid out control panel offers the greatest ease of use and maximum productivity. The machine functions are displayed graphically and controlled by high-quality switches. The infeed thickness is displayed as an overview on the digital display and can be adjusted in increments of 0.1 mm using the push button.



Either as an option or as standard with a segmented sanding shoe, the machine is equipped with a touchscreen control. All adjustments can be intuitively and easily carried out using the central operating panel. For maximum processing safety, the parameters can be stored as a program and retrieved later.

Options

In and outfeed roller table (option)

The table extensions improve the angle at which workpieces are feed into the machine and also make it easier to process.

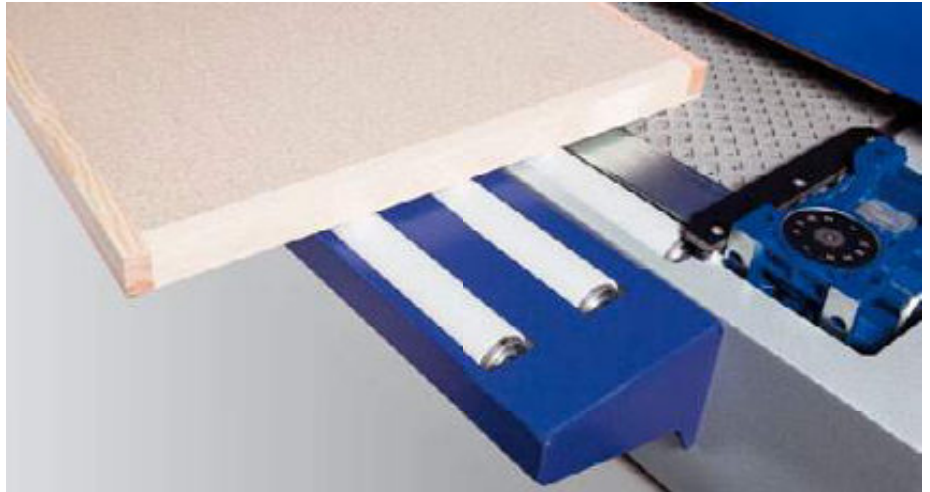

Brushing equipment

The brush assembly mounted on the outfeed side can be fitted with a wide range of brushes. The workpieces are cleaned, polished or structured depending on the type of brush.

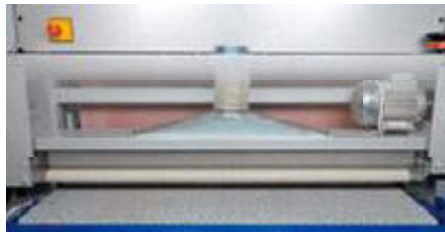

Variable sanding belt speed

The sanding belt speed can be adjusted from 3–20 m/s to suit different surfaces.

Automatic thickness measurement

Automatic thickness measurement facilitates adjustment of the machine to the desired workpiece thickness. The workpiece is measured directly on the machine without additional measuring devices being required.

Technical specifications



| | finish 1102 | finish 1302 |
|---|----------------|----------------|
| Sanding belt motor | 11 kW (15 HP) | 11 kW (15 HP) |
| Ammeter for monitoring the electrical load on the units | S | S |
| Sanding belt | 1110 x 2200 mm | 1310 x 2200 mm |
| Vacuum table with ventilator | 4.5 kW | 4.5 kW |
| Rolling table extension for feeding workpieces 300 mm | ○ | ○ |
| Variable feed speed adjustment | 2,8–20 m/min | 2,8–20 m/min |
| Working height | 780–893 mm | 780–893 mm |
| Length [L] | 1604 mm | 1804 mm |
| Width [W] | 2232 mm | 2232 mm |
| Vacuum connection, extraction port/outlet (without additional / optional equipment) | 2x 160 mm | 2x 200 mm |

S ... Standard



Further information about the technical data, individual configuration options and all noise level values can be found on the internet at www.format-4.com

Space requirement

Scale
1:50

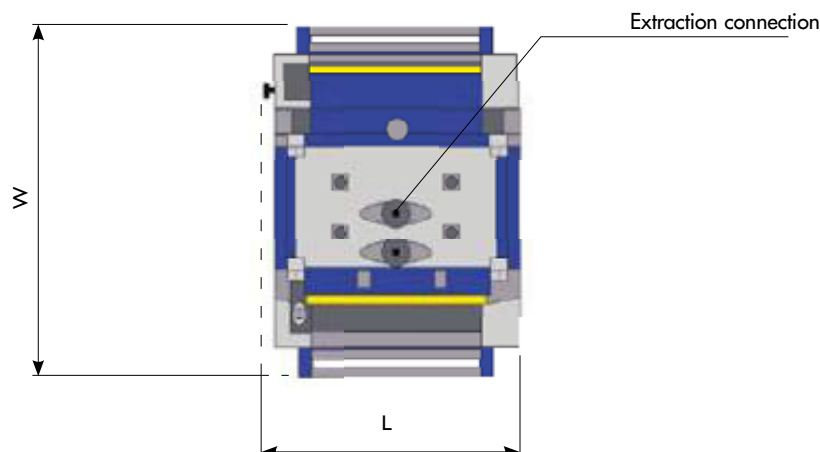

Actual machine may differ from symbolic image finish 1102, finish 1302

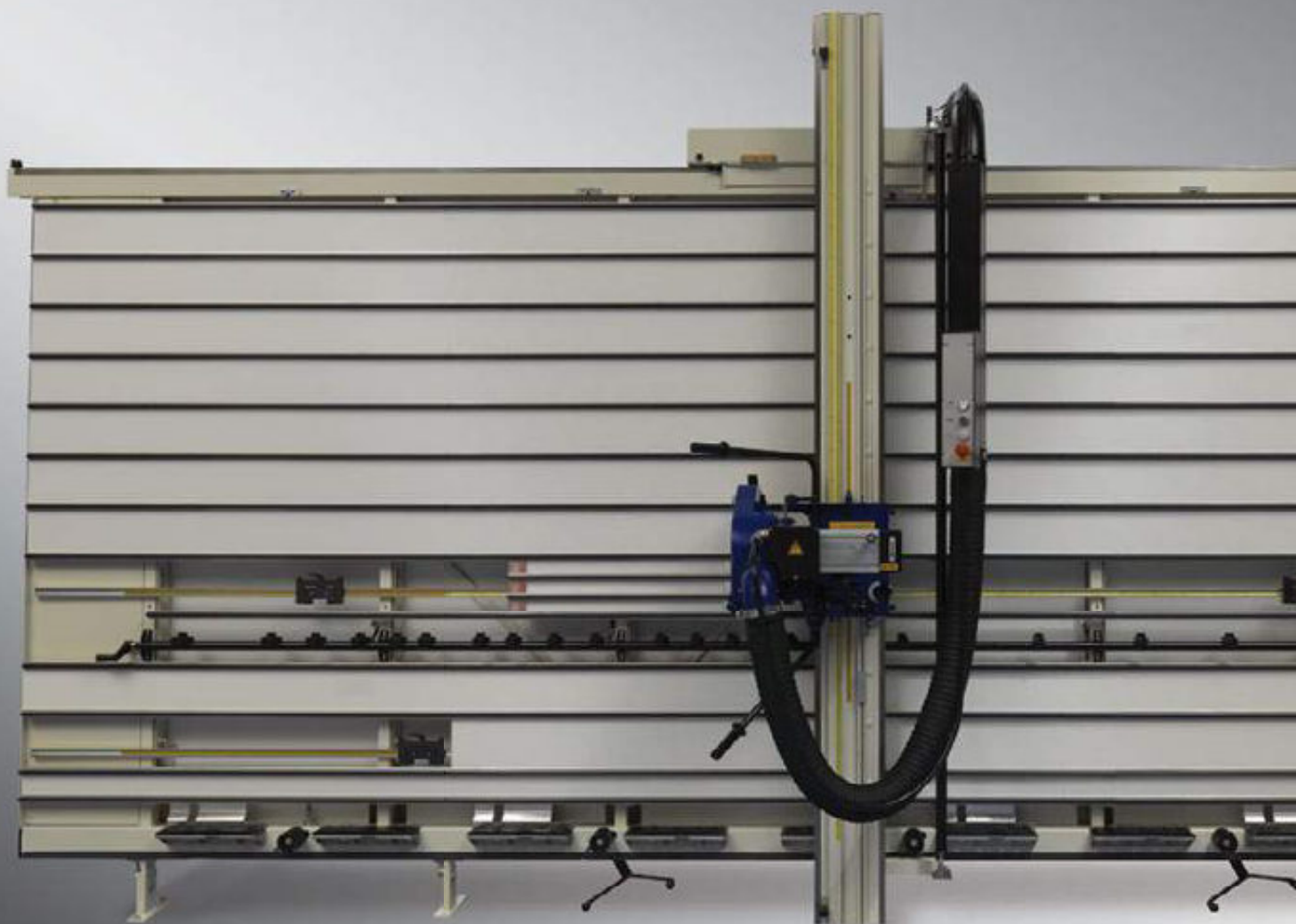

kappa V60

Powerful, accurate and space saving

The new Format-4 vertical panel saw will increase your productivity. The solid, single piece frame construction and a saw carriage running on steel rails guarantees a cut accuracy to one tenth of a millimetre.

The handling and operation of the machine are facilitated with the help of a wide range of accessories, already included as part of the machine's standard equipment!



Saw unit

The saw unit is guided on steel rails and as a result, executes cuts accurate to one tenth of a millimetre.

A high-torque motor 4 kW, a saw blade diameter of 250 mm (optionally with a scoring unit) provides a 60 mm depth of cut.



Additional fence

An additional stop is included as part of the standard equipment to help cut narrow strips to length.

Centre support

A bipartite central support designed for small workpieces runs along the total cutting length and can be easily swung out of the way when not required.

TRC dust extraction

Integrated powerful TRC dust extraction. Dust emissions considerably below 1 mg/m³.

- Saw motor: 4 kW
- Saw blade diameter 250 mm
- Cutting length 4200 mm
- Depth of cut 60 mm

Moveable rear wall

(Moving spacers)

When cutting horizontally the spacers move vertically to avoid being damaged by the saw blade.





kappa automatic 55 kappa automatic 75

Redefining productivity

Beam saws are essential for high end production. The Format-4 kappa automatic beam saw guarantees quick cutting cycles and perfect cutting results. The modular cutting optimisation program, with barcode labelling for the next processing steps, guarantees maximum process reliability. Numerous specification options make it possible to configure the machine to individual manufacturing processes.

Chip free, precise cutting quality



Saw carriage with main blade and scoring unit

The saw carriage with main blade and scoring blade runs on ground and hardened round guides and ensures an extremely smooth movement and an exact right angle.

The cutting height can be set manually, pneumatically or electromotive.

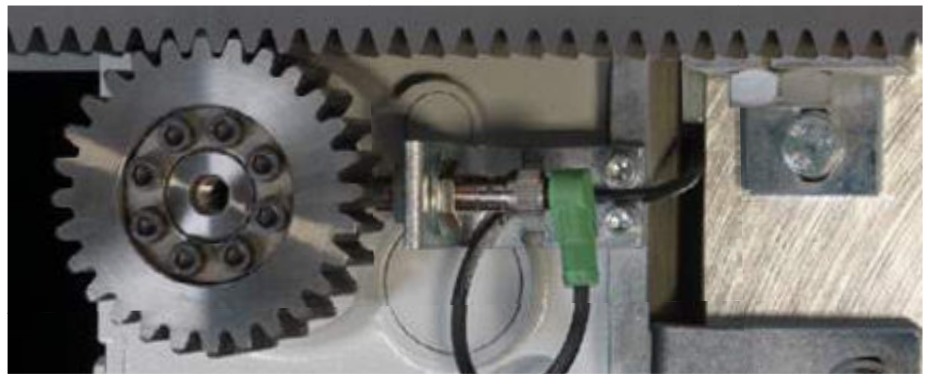

Saw carriage drive

The constant speed of the saw carriage is variable and can be set between 5–100 m/min from the control panel. The rack and pinion system on which the carriage runs guarantees a constant cutting quality regardless of the material being processed.

Workpiece transport

Solid steel clamps, pneumatically controlled, guarantee a safe and damage-free clamping of panel stacks (opening height 80 mm) and individual small panels.



- Chip free, precise cutting quality
- Simple to operate
- Short cutting cycles
- Maximum repeatability
- Perfect process reliability
- Reliable production flow
- Flexible

Short cutting cycles

Automatic cutting length detection:

A laser sensor on the saw carriage identifies the end of the panel and stops the carriage once the cut is completed automatically. The saw blade and scoring blade drop automatically below the level of the table and move back to the starting position. Cutting cycles are practically reduced to the time it takes to load and unload the material.

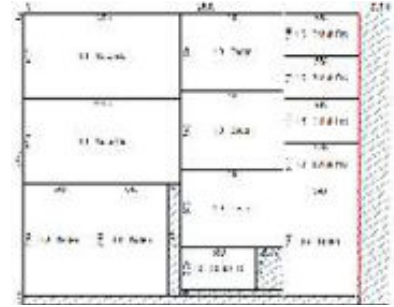
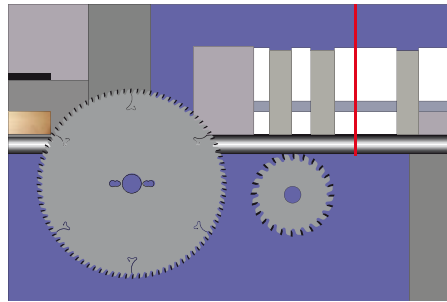
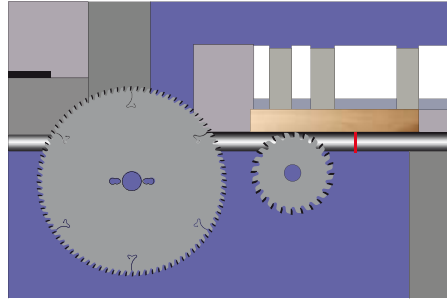

Cutting optimisation software

The modular cutting optimisation software uses the material list to calculate the most economic cutting process taking the cutting times and amount of waste into consideration. Compatible with the majority of construction and design programs it is also possible to calculate the amount of material and length of edge required, cutting times and/or be connected to a warehousing system with material administration.



Effective loading using a lifting table/panel warehousing system

With the lifting table/panel warehousing system attached to the rear, it makes it possible to load the saw, panel by panel. The panels required can be loaded directly from the stack of panels onto the saw.



Cutting stacked panels

The saw blade projection of 55 or 80 mm in combination with a powerful drive unit offers the possibility to cut several stacked panels in one run which helps to increase production speed significantly.

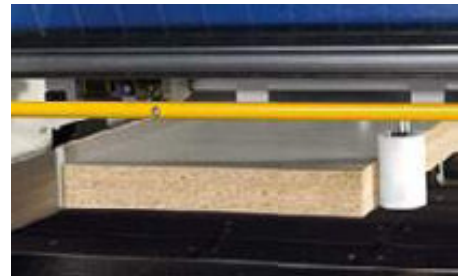

Pressure device

The pressure device with roller, pushes the workpiece against the side fence and ensures an exact right angle (for workpieces with a width of 50–1200 mm)

Simple to operate

Easy operation is guaranteed by the simple design of the control panel and clear menu configuration of the control software based on the Windows design. A connection of the machine control to existing systems or networks is available. The kappa automatic can be equipped with the Ardis cutting optimisation software. As an option, the panel saw can also be equipped with a label printer.



Maximum repeatability

| Individuelle Kennlinie | | Wert | |
|------------------------|-----|------|-----|
| 1 | 1.0 | 1.0 | 1.0 |
| 2 | 1.0 | 1.0 | 1.0 |
| 3 | 1.0 | 1.0 | 1.0 |
| 4 | 1.0 | 1.0 | 1.0 |

| Teillisten (1) | | | | | | |
|----------------|---------|---------|-------|---------------|----------|-----|
| Disc | Message | Uhrzeit | Druck | Druckrichtung | Material | |
| 1 | | 1.0 | 1.0 | 1.0 | 1.0 | 1.0 |
| 2 | | 1.0 | 1.0 | 1.0 | 1.0 | 1.0 |
| 3 | | 1.0 | 1.0 | 1.0 | 1.0 | 1.0 |
| 4 | | 1.0 | 1.0 | 1.0 | 1.0 | 1.0 |

Saved cutting plans

Cutting plans from previous projects can be saved and later recalled. By using the "multiplier" function, the workpiece can be reproduced as needed.



Double measuring system on the material pusher

The material positioning unit is equipped with two measuring systems that constantly monitor each other. The combination of a highly precise servomotor and solid material grips ensure maximum repeatability. The measuring system is separate to the drive system and is completely free from wear and tear.

Perfect process reliability



Label

In combination with the cutting optimisation software a label can be printed for each workpiece with various information (order number, intended use, CNC program, which side is to be put through edgebander).

Reliable product handling

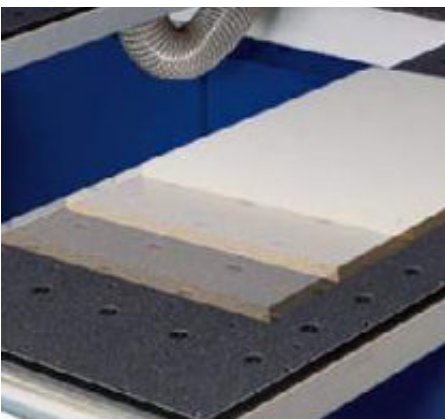

Material compatible handling

Unloading tables with air cushion technology guarantee a smooth handling of the material and a constant production flow especially when processing stacks of panels. Wheel conveyors situated near the material pusher ensure a gentle positioning of the material. For particularly pressure sensitive material the clamping pressure of the clamps can be adjusted using a manometer.

Flexible

Optimised additional equipment enables the perfect customisation to the customer specific manufacturing process.

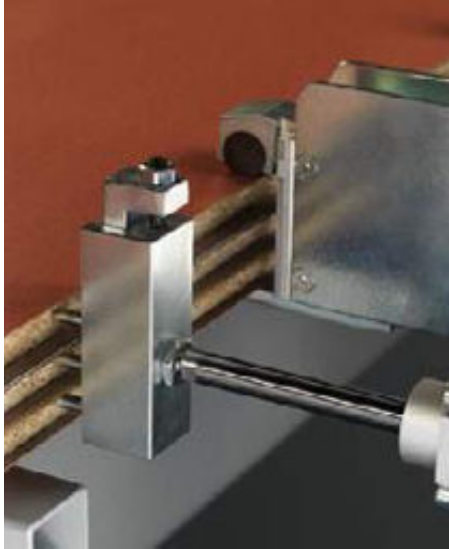

Veneer fences

Pneumatic veneer fences are available for panel cuts of veneered panel materials with a veneer projecting edge or laminated panels.

Electrical cutting height adjustment with groove function

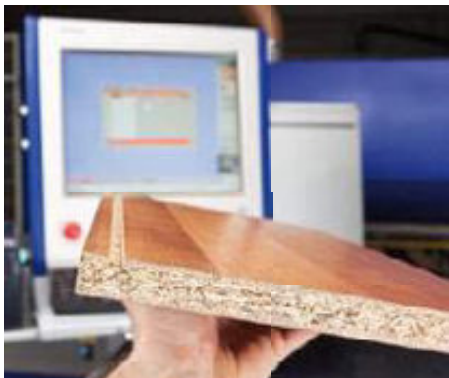

Variable speed control of the main saw blade 2000–6000 rpm

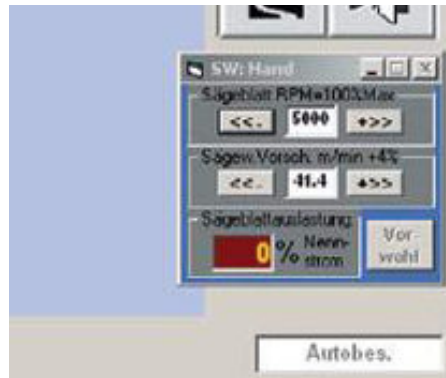

Additional clamping unit



Additional unloading table

Technical specifications



| | kappa automatic 55 3200 x 3200 | kappa automatic 75 3200 x 3200 | kappa automatic 75 4300 x 4300 | kappa V60 |
|-------------------------|-----------------------------------|-----------------------------------|-----------------------------------|------------|
| Cutting length 3200 mm | S | S | - | - |
| Cutting length 4300 mm | - | - | S | - |
| Cutting length 4200 mm | - | - | - | S |
| Cutting length 5300 mm | - | - | - | O |
| 5.5 HP (4.0 kW) | - | - | - | S |
| 7.5 HP (5.5 kW) | S | - | - | - |
| 12.0 HP (9 kW) | - | S | S | - |
| Material feeder depth | 3200 mm | 3200 mm | 4300 mm | - |
| Sawblade-Ø | 320 mm (projection) 55 mm | 320 mm (projection) 80 mm | 320 mm (projection) 80 mm | 250 mm |
| Length [L] | 5430 mm | 5430 mm | 6530 mm | 5600 mm |
| Width [W] | 6607mm | 6607mm | 7705 mm | 2985 mm* |
| Extraction connection-Ø | 100+100+100 mm | 100+100+100 mm | 100+100+100 mm | 100+100 mm |

S ... Standard equipment O ... Option - ... Not available
*without strip fence



Further information about the technical data, individual configuration options and all noise level values can be found on the internet at www.format-4.com

Space requirement

Scale

1:75

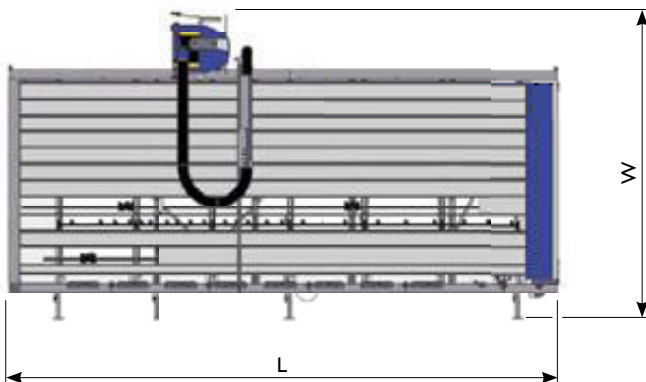

Symbolic image kappa V60

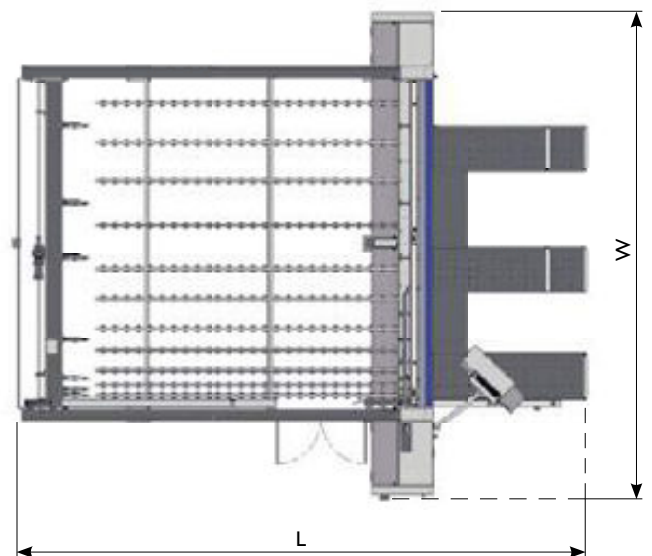

Symbolic image kappa automatic 55, kappa automatic 75

Dimensions given can vary if special equipment is used



HVP

Heated veneer presses in every class of size and performance!

High quality yet extremely cost-efficient veneer pressings are feasible with the new Format-4 heating platen presses! Depending on your requirements, there are 5 different machine types with 12 variations to choose from.



Control panel

Quick and simple operation, without any separate programming or training necessary. The pressing pressure required can be taken directly from the pressing information and set using the pressure regulator. This ensures that time consuming programming of length and width is not required. A timer guarantees that the plates open once the set pressing time has been reached. It is also possible to set how wide the plates should open.



Synchronised rack and pinion guide

The large dimensioned rail guides and torsionally rigid joints guarantee a parallel lift of the pressing plates.



Sensor monitoring

Magnetic sensors monitor the parallel lift of the pressure plates and prevent uneven pressure build-up over the length of the plates.

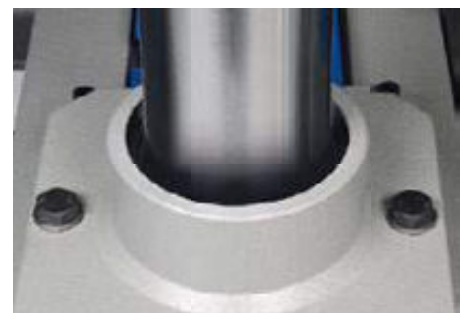

Heating systems

- with Elkom® electric heating platens
- with warm water heating (90°)
- with Thermo oil heating (120°)
- with external water connection

- Solid build
- Simple to operate
- Durable machine construction
- High quality components

Raised cylinder guide

By raising up the upper lip of the hydraulic cylinder casing, the cylinder is constantly coated in oil. This prevents the cylinder seals from drying out and therefore, extends their usable life.

ELKOM electric heating platens

The electric heating plates are covered with a strong aluminium plate on the pressing side which is inside a thermal casing in which the heating elements are embedded. The casing ensures an optimal heat flow in the direction of the pressing surface. For increased stability there is an additional aluminium panel which is in turn sealed off by a thermal insulation. The electric hot plates can be used up to a maximum operating temperature of 120°C. As an option the pressing surface can also be supplied with gold anodisation.

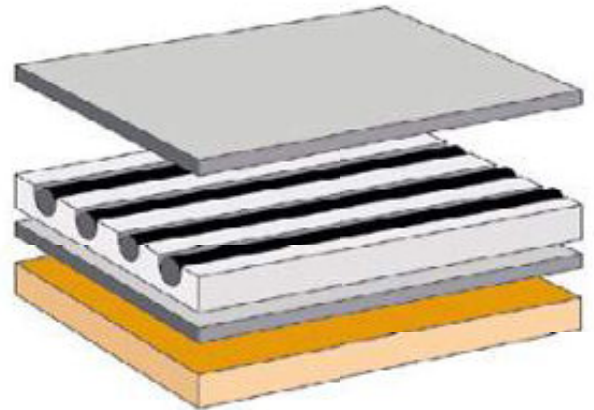

Fabricated steel plate

The plate is manufactured with a sandwich design. The core is covered above and below with solid steel plates. Inside, a steel pipe construction provides the necessary channels to transport water or oil and ensures the necessary stability. The pressing surface is coated with aluminium and additionally as an option can be equipped with a Mylar coating. Using water you can reach a maximum operating temperature of 90°C. Using oil as the heating method you can work at temperatures up to 120°C.

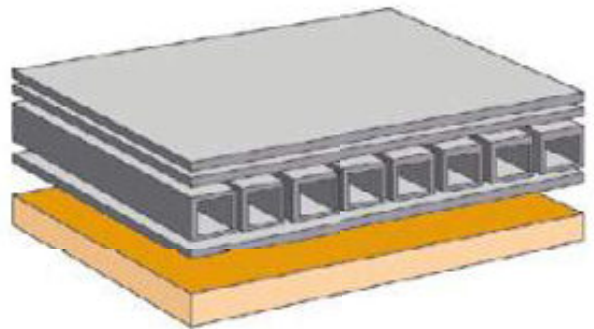

Solid drilled steel plates

The heating channels are drilled into a solid steel body, through which warm oil runs bringing the steel body to the operating temperature. This heavy duty design enables a maximum pressure of up to 40kg/cm². The maximum operating temperature of these plates is 250°C.

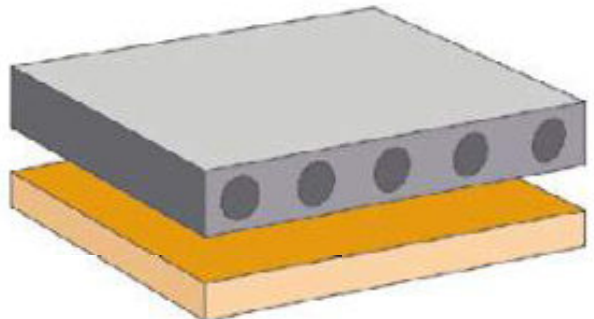

Technical specifications



| | HVP 50 | HVP 60 | HVP 70L | HVP 90/90L/90XL | HVP 120/120L/120XL | HPV 160L | HPV 160XL | HPV 200XL |
|---|----------------|----------------|----------------|--|--|----------------|----------------|----------------|
| Press power (t) | 50 | 60 | 70 | 90 | 120 | 160 | 160 | 200 |
| kg/cm ² (at 80% load capacity) | 1.9 | 2.3 | 2.2 | 3.5/2.9/2.5 | 4.6/3.8/3.3 | 5.1 | 4.4 | 5.5 |
| Heating plates length | 2500 mm | 2500 mm | 3000 mm | 2500/3000/3500 mm | 2500/3000/3500 mm | 3000 mm | 3500 mm | 3500 mm |
| Heating plates width | 1300 mm | 1300 mm | 1300 mm | 1300 mm | 1300 mm | 1300 mm | 1300 mm | 1300 mm |
| Stroke | 400 (650) | 400 (650) | 400 (650) | 400 (650) | 400 650 | 400 (650) | 400 (650) | 400 (650) |
| Pressing cylinders (pc) | 4 | 4 | 6 | 6 | 6 | 8 | 8 | 10 |
| Pressing cylinders-Ø | 70 mm | 70 mm | 70 mm | 70 mm | 85 mm | 85 mm | 85 mm | 85 mm |
| Weight | 3100–3700 kg | 3100–4500 kg | 3700–5200 kg | 3200–4700 kg 3700–5400 kg 4800–6500 kg | 3500–5200 kg 4000–5700 kg 5000–6800 kg | 4300–6000 kg | 5500–7300 kg | 7800–9600 kg |
| Length [L] | 3100 mm | 3100 mm | 3700 mm | 3100/3700/4200 mm | 3100/3700/4200 mm | 3700 mm | 4200 mm | 4200 mm |
| Width [W] | 1600–1770 mm | 1600–1770 mm | 1600–1770 mm | 1600–1770 mm | 1600–1770 mm | 1600–1770 mm | 1600–1770 mm | 1600–1770 mm |
| Height [H] | 1800 (2370) mm | 2000 (2370) mm | 2000 (2370) mm | 2000 (2370) mm | 2000 (2370) mm XL 2100 (2450) mm | 2100 (2370) mm | 2200 (2450) mm | 2200 (2450) mm |



Further information about the technical data, individual configuration options and all noise level values can be found on the internet at www.format-4.com

Space requirement

Scale
1:50

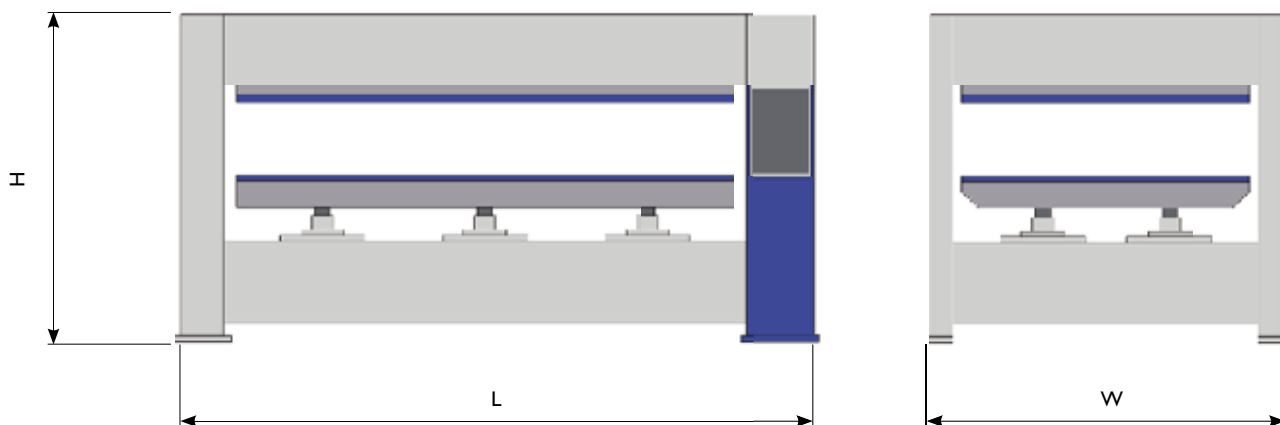

Symbolic image HVP

Dimensions given can vary if special equipment is used

Visit us online and see:

- All our machines and key features
- Videos
- Current offers
- Tooling and Accessories
- All technical data

www.format-4.com



FORMAT

3.3. Leibniz Zentrum



▼ PRODUKTE SHOP ▼ ÜBER FORMAT-4 ▼ PRESSE ▼ VIDEO SCHAURÄUME

Suchen:



NEUHEITEN

- ✓ Patentierte Highload-Systemlösungen
- ✓ Hochwertige Verarbeitung
- ✓ Präzision der Premiumklasse
- ✓ Konstante Zuverlässigkeit
- ✓ Formvollendetes Maschinendesign
- ✓ Unschlagbare Einführungspreise

FORMAT-4

VIDEO

[mehr](#)

FORMAT-4 Formatkreisläufigen Holzbearbeitungsmaschinen CNC-Bearbeitungszentrum Kantenanleimmaschinen Reinluft-Absauggeräte

Format-4 Holzbearbeitungsmaschinen der Premiumklasse für Handwerk, Gewerbe und Industrie. Design, Präzision und Bedienkomfort bei exklusiver Standardausstattung zu einem extrem fairen Preis.

DOWNLOADS

[mehr](#)

DAS WAR DIE LISNA 2013

Entdecken Sie unsere Maschinen und gewinnen Sie einen Ausblick auf die LISNA 2013!

[mehr](#)



WORLD SKILLS 2013 IN LEIPZIG

Weltmeisterliche Leistungen mit FELOER, den Maschinen für Champions

[mehr](#)





FORMAT-4 product range

Panel Saws



kappa 550
kappa 550 x-motion/e-motion



kappa 400
kappa 400 x-motion

Spindle Moulders



exact 63



dual 51



profil 45 Z
profil 45 Z x-motion

Edgebanders



perfect 812 x-motion plus
perfect 812 e-motion



perfect 710 x-motion
perfect 710 e-motion



perfect 608 x-motion plus

CNC Machining Centres



profit H50/H50L



profit H22/H22L



profit H20

Planer-Thicknesser/Planers/Thicknessers



plan 51



plan 51L



exact 51

Wide Belt Sanders



profil 45 M
profil 45 M x-motion



finish 1302



finish 1102

Industry panel saws



kappa automatic 55/75



kappa V60



HVP

Heated Veneer Press



profit H10



profit H08



cexpress 920





FORMAT-4 Austria

KR-Felder-Straße 1
6060 HALL in Tirol
Austria

Tel. +43 (0) 52 23 55 306

Fax +43 (0) 52 23 55 306-63

E-Mail: info@format-4.com

www.format-4.com

Immediate-Info:

 Tel. +44 (0) 1908 635000
Fax +44 (0) 1908 307000
www.format-4.co.uk

 Tel. +61 (0)2 4735 1011
Fax +61 (0)2 4735 8222
www.format-4-australia.com

 Tel. +91 (0) 22 3373 4300-98
Fax +91 (0) 22 3373 4399
www.format-4-india.com

 Tel. +353 (0) 21-4633222
Fax +353 (0) 21-4634297
www.format-4.ie

A/14F4-09-EUK/S/1,00/V/2710

