

Boring System Evolution 1000

Foratrice automatica/Automatic boring machine
Perceuse automatique/Taladro automatico



50

ANNIVERSARY
1963 - 2013



Boring System Evolution 1000

Foratrice automatica / Automatic boring machine Perceuse automatique / Taladro automatico

Foratrice automatica CNC a pannello passante a foratura dal basso e ritorno automatico all'operatore.
Scarico pannello anteriore e posteriore.

EQUIPAGGIAMENTO STANDARD

- Controllo integrato nella macchina
- PC Industriale modello Attiva Micro Atom Windows XP, casa produttrice CNI. Monitor a colori da 15", con lettore CD, tastiera e mouse.
- Software ILENIA CAD - CAM 4. Porta USB.
- Piani d'appoggio anteriore e posteriore (1200x400 mm)

CNC automatic boring machine - accurate drilling from underneath with automatic operator return.
Front and back panel unloading.

STANDARD EQUIPMENT

- Machine integrated control panel
- Industrial PC model Attiva Micro Atom Windows XP, developed by CNI. 15" colour monitor, CD, keyboard and mouse.
- ILENIA CAD -CAM 4 software. USB connection.
- Panel supports forward and backward (1200x400 mm)

Perceuse automatique CNC à panneau passant, perçage par dessous et retour automatique vers l'opérateur.
Déchargement avant et arrière du panneau.

EQUIPEMENT STANDARD

- Panneau de commande intégré dans la machine
- PC industriel, modèle Attiva Micro Atom Windows XP, produit par Sté CNI. Ecran tactile couleurs 15" avec lecteur CD, clavier et mouse.
- Software ILENIA CAD - CAM 4, port USB.
- Plans d'appui avant et arrière (1200x400 mm)

Taladro automatico con control numérico y panel pasante, horadación de abajo arriba y vuelta automática al operador.
Descarga paneles anterior y posterior.

COMPOSICION ESTANDAR

- Cuadro de mandos integrado en la maquina
- PC industrial modelo: Attiva Micro Atom Windows XP, fabricado por CNI. Monitor de colores 15", CD, teclado y ratón. Software ILENIA, CAD - CAM 4, puerto USB
- Planos de apoyo anterior y posterior (1200x400 mm)

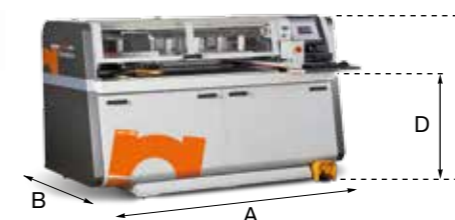
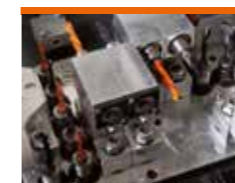
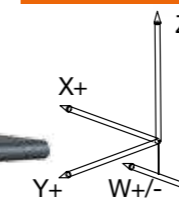
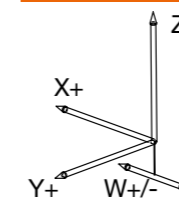
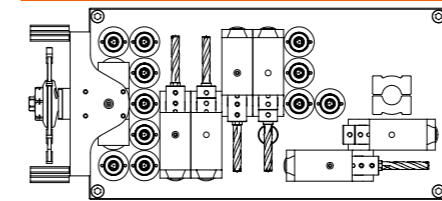
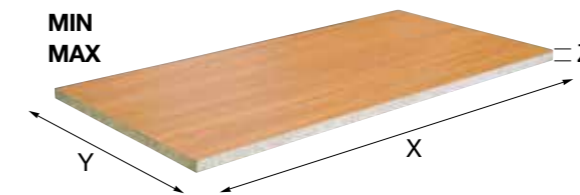

Boring System Evolution 1000

X 300 / 3200 mm
Y 120 / 1000 mm
Z 8 / 50 mm

N 11 Verticale / Vertical

N 5 Orizzontale / Horizontal

N 1 Lama / Saw blade
Lame à rainure / Sierra para ranura

32 mm

N 4

X, Y, Z- Servoassistito / Power assisted
Servomécanisme / Servo-asistida

W Pneumatico / Pneumatic
Pneumatique / Neumatico

MAX 50 mm

X 42 m/min
Y 42 m/min
Z- 10 m/min
W 42 m/min

RPM 3200

N 3
BRUSHLESS

kW 3

A 2200 mm
B 1500 mm
C 1500 mm
D 900 mm

850/1200 kg

Dettagli

Details/Détails/Detailles

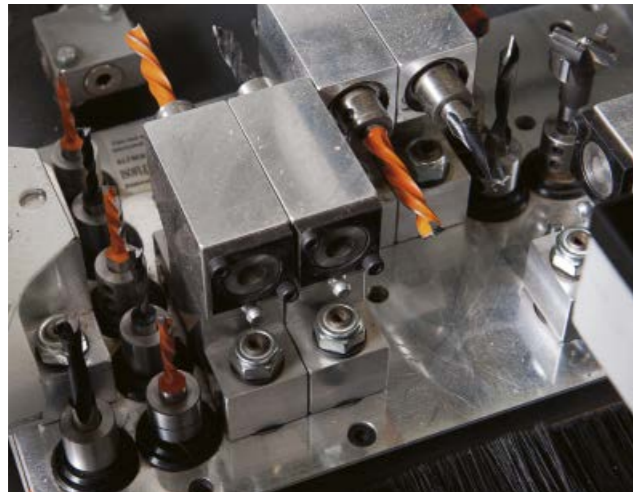

- TESTA MULTIPLA STANDARD
- MULTIPLE HEAD STANDARD
- TÊTE DE PERÇAGE MULTIBROCHE STANDARD
- CABEZAL MULTIPLE ÉSTANDAR

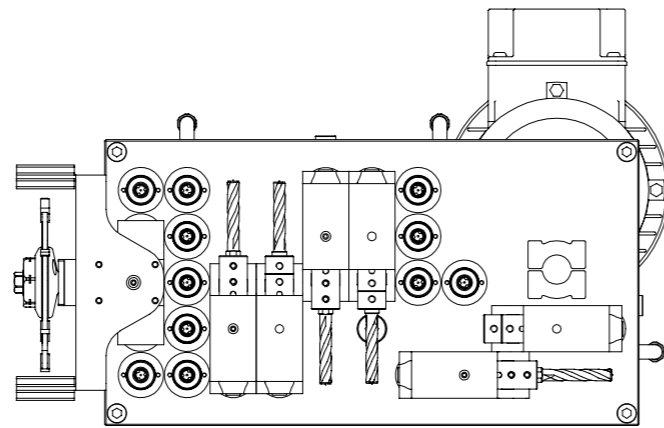

- N. 11** Mandrini verticali / Vertical spindles
Mandrins verticaux / Mandriles verticales
- N. 4** Mandrini orizzontali / Horizontal spindles
Mandrins horizontaux / Mandriles horizontales
- N. 1** Lama / Saw blade / Lame à rainure / Sierra para ranura
- N. 1** Mandrini orizzontali per 4° lato / Horizontal spindles for 4th side
Mandrins horizontaux pour 4eme côté / Mandriles horizontales por el 4° lado



- VITI A RICIRCOLO DI SFERE
- BALL SCREWS
- VIS À ROULEMENT DE BILLES
- TORNILLOS A RECIRCULACIÓN DE COJINETES DE BOLAS



- BATTUTA LASER
Controlla la misura del pannello e in funzione alla lunghezza reale riprogramma la posizione dei fori.
- LASER MEASURING TOOL
To determine the dimensions of the working panel and to reset the boring process according to the real length of the panel itself.
- BUTÉE LASER
Qui contrôle la dimension du panneau et en fonction de la longueur réelle il reprogramme la position des trous.
- TOPE DE RÉFÉRENCIA CON LÁSER
Averigua las dimensiones del panel y replantea la posición del taladro con respecto del largo real.



- SOFTWARE ILENIA CAD CAM 4
- Sistema parametrico completo di Cad/4 integrato
- Macro di lavorazioni standard per foratura e taglio
- Distinte di lavoro interattive
- Backup programmi
- Collegamento USB

OPTIONAL

Post-processor per compatibilità con altri tipi di Cad, espandibile con Macro personalizzate.

- ILENIA CAD CAM 4 SOFTWARE

- Parametric system including Cad/4
- Macros to carry out standard boring and cutting working procedures
- Interactive job lists
- Back up programs
- USB connection

OPTIONAL

Post-processor to make it suited to other Cad programs, possibility of integration with customized Macros.

- SOFTWARE ILENIA CAD CAM 4

- Système paramétrique complet de Cad/4 intégré
- Macro des opérations standard utilisables pour perçage et coupe
- Bordereaux de travail interactifs
- Backup programmes
- Connexion USB

OPTION

Post-processor pour compatibilité avec des autres types de CAD, possibilité d'expansion avec Macro personnalisées.

- SOFTWARE ILENIA CAD CAM 4

- Sistema de gestión paramétrico con CAD/4 integrado
- Macros para operaciones estándar de taladro y de corte
- Hojas de trabajo interactivas
- Backup programas
- Conexión USB

ACCESORIO

Post-procesador para la conversión de otras tipologías de CAD en formatos compatibles y para la incorporación de macros personalizadas.

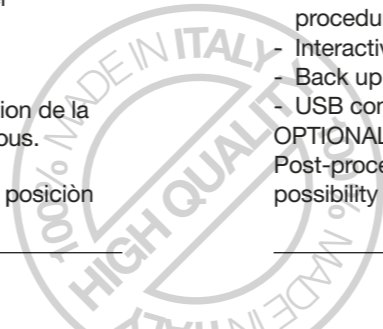

Dettagli

Details/Détails/Detailles



- **ACCOPPIAMENTO PERFETTO DEI PANNELLI**
Innovativo sistema di foratura orizzontale, 4°asse e pannello bloccato sul piano garantiscono un accoppiamento preciso anche di pannelli non perfettamente planari.
- **PERFECT ASSEMBLY OF PANELS**
Innovative drilling procedure: 4th axis and effective clamping ensure an accurate assembly of the wooden panels even though their surface is not perfectly flat.



- **ACCOUPLÉMENT PARFAIT DES PANNEAUX**
Système innovant de perçage horizontal, le 4ème axe et le blocage du panneau sur le table de travail garantissent une jonction optimale même avec des panneaux qui ont des défauts de planéité.
- **PERFECTO ACOPLAMIENTO DE LOS PANELES**
Sistema innovador del taladro horizontal, 4° eje y bloqueo optimal del panel sobre la mesa de trabajo garantizan el perfecto acoplamiento del panel aún que no esté perfectamente plano.

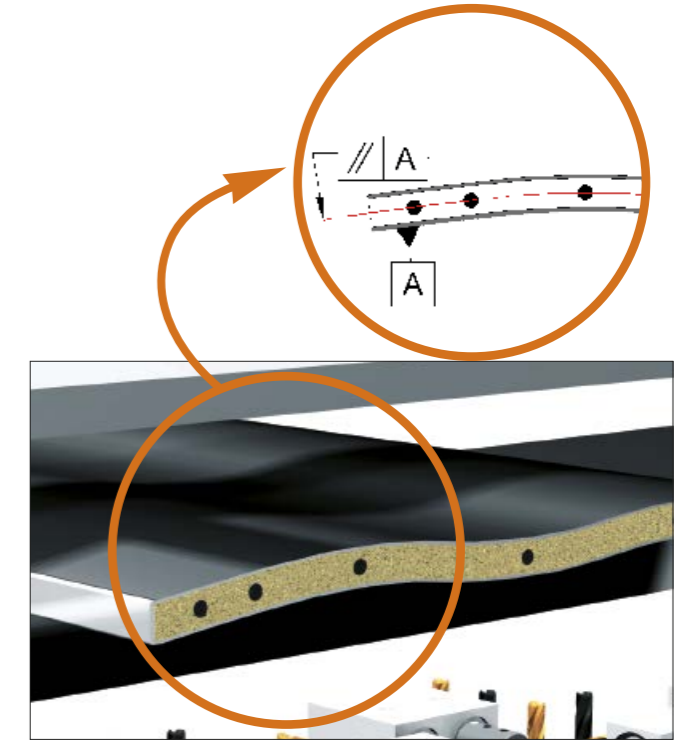

- **PIANO A VELO D'ARIA**
- **AIR FLOATION TABLE**
- **TABLE DE TRAVAIL À COUSSIN D'AIR**
- **MESA DE TRABAJO CON PATINES A COLCHÓN DE AIRE**



- **LUBRIFICAZIONE AUTOMATICA DEGLI ASSI**
- **AUTOMATIC LUBRICATION OF THE AXES**
- **GRAISSAGE AUTOMATIQUE DES ESSIEUX**
- **LUBRICACIÓN AUTOMÁTICA DE LOS EJES**

- **Esempi di lavorazione**
- **Working examples**
- **Exemples de travail**
- **Ejemplos de trabajo**

