

Tradition. Ambition. Vision.

Find out more about the future at randek.com

ENG

2202

BUTTERFLY TABLE BS20

RANDEK 

BUILDING THE FUTURE

BS20 BUTTERFLY TABLE

FLEXIBLE AND EFFICIENT
SYSTEM FOR PREFABRICATED
HOUSE MANUFACTURING

Randek Butterfly Table BS20 is a flexible and effective system for production of almost any type of building element such as: walls, floors, inner/outer roof and gable ends.

BS20 is developed for production of prefabricated building elements and is a popular machine for start-up companies but also larger producers use the system in their production.

BS20 tables are standard equipped with functions to ensure a high-quality and effective production. Beyond this there are many additional functions available, developed together with our successful customers around the world.

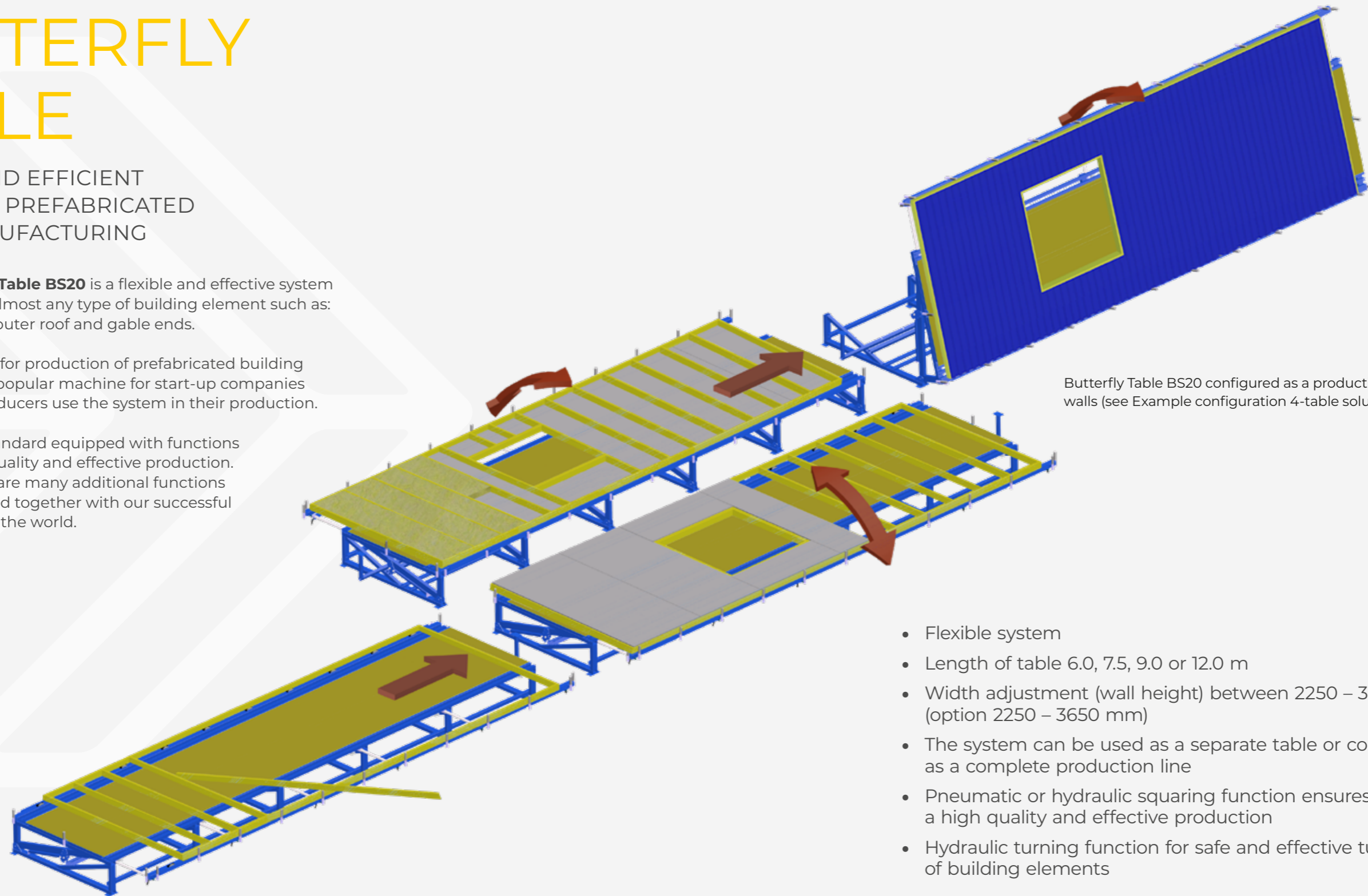

Butterfly Table BS20 configured as a production line for walls (see Example configuration 4-table solution, page 8)

- Flexible system
- Length of table 6.0, 7.5, 9.0 or 12.0 m
- Width adjustment (wall height) between 2250 – 3100 mm (option 2250 – 3650 mm)
- The system can be used as a separate table or configured as a complete production line
- Pneumatic or hydraulic squaring function ensures a high quality and effective production
- Hydraulic turning function for safe and effective turning of building elements

UPRAISE TABLE

Upraise Table is the starting point for most BS20 system. The table is equipped with pneumatic squaring function and width adjustment function. The table is covered with plywood and removable support pins for squaring of the building elements are placed on both sides of the table.

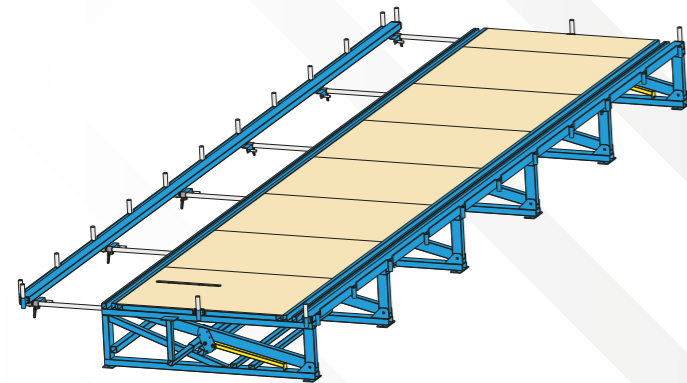

✔ Included ➔ Option

Basic design	
Function	
Hydraulic Turning - 90 degrees	✔
Hydraulic Turning - 80 degrees	➔
No Turning	➔
Fixed rollers, 2 rows	➔
Fixed rollers, 3 rows	➔
Upraisable Rollers, 2 rows	➔
Upraisable Rollers, 3 rows	➔
Manual Width Adjustment - No squaring	➔
Manual Width Adjustment - Pneumatic squaring	✔
Extended Manual Width Adjustment - Pneumatic squaring	➔
Hydraulic Width Adjustment - Hydraulic squaring	➔
Extended Hydraulic Width Adjustment - Hydraulic squaring	➔
C-Bars, Across	➔
Hole Beams, Across	➔
Hole Beams, Short side (2 pc)	➔
Vertical Outfeed of Wall Element	➔
Air Supply for Pneumatic Tools	➔
Plywood	✔
C-bars, Lengthwise	✔
Removable support pins (fixed side)	✔
Removable support pins (movable side)	✔
Removable support pins (short side)	✔

FUNCTION DESCRIPTION

- Adjust the width of the table
- Build the timber framework directly of the table, top/bottom plate and studs
- Square the building element to 90 degree building element with high quality
- Nail the timber framework form both sides
- Perform manual operations such as installation, insulation, nailing of boards etc
- Initiate the turning process, the receiver table and upraise table is erected and the building element is turned

Technical description	BS10U-060	BS10U-075	BS10U-090	BS10U-120
Timber Framework - Length	6000 mm	7500 mm	9000 mm	12000 mm
Max lift capacity (element height = 2,5 m)*	1000 kg	790 kg	1450 kg	2000 kg
Working height	620 mm			
Timber Framework - Thickness	63 - 300 mm (element thickness is limited by weight)			
Timber Framework - Height	2250 - 3100 mm (option 2250-3650 mm)			
Safety	The machine is equipped with emergency stop			
Consumption - Electricity	3 x 400 VAC +N +PE 16A 50 Hz - Contact Randek for consultation			
Consumption - Air	7 bar			

* Increased max lift capacity upon request

RECEIVER TABLE

Receiver Table is normally the second table that receives the building element after the turning. The table is covered with plywood. Removable support pins for turning of the element are placed on one side of the table.

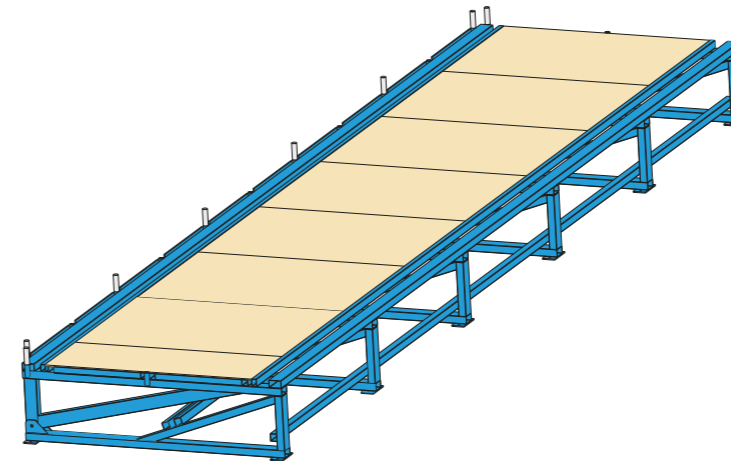

✔ Included ➔ Option

Basic design	
Function	
Hydraulic Turning - 90 degrees	✔
Hydraulic Turning - 80 degrees	➔
No Turning	➔
Fixed rollers, 2 rows	➔
Fixed rollers, 3 rows	➔
Upraisable Rollers, 2 rows	➔
Upraisable Rollers, 3 rows	➔
Manual Width Adjustment - No squaring	➔
Manual Width Adjustment - Pneumatic squaring	➔
Extended Manual Width Adjustment - Pneumatic squaring	➔
Hydraulic Width Adjustment - Hydraulic squaring	➔
Extended Hydraulic Width Adjustment - Hydraulic squaring	➔
C-Bars, Across	➔
Hole Beams, Across	➔
Hole Beams, Short side (2 pc)	➔
Vertical Outfeed of Wall Element	➔
Air Supply for Pneumatic Tools	➔
Plywood	✔
C-bars, Lengthwise	✔
Removable support pins (fixed side)	✔
Removable support pins (movable side)	➔
Removable support pins (short side)	✔

FUNCTION DESCRIPTION

- Continue the turning process and lower the wall. Both upraise and receiver table are lowered and the building element is turned over.
- Perform manual operations such as: installation, insulation, board nailing etc
- Fasten the lifting straps to a conveyor system or to other lifting equipment. Raise the table and pull the building element using the conveyor system at the same time. When reaching 90 degrees the building element is removed from the working station.

Technical description	BS10R-060	BS10R-075	BS10R-090	BS10R-120
Timber Framework - Length	6000 mm	7500 mm	9000 mm	12000 mm
Max lift capacity (element height = 2,5 m)*	1000 kg	790 kg	1450 kg	2000 kg
Working height	620 mm			
Timber Framework - Thickness	63 - 300 mm (element thickness is limited by weight)			
Timber Framework - Height	2250 - 3100 mm (option 2250-3650 mm)			
Safety	The machine is equipped with emergency stop			
Consumption - Air	Supplied from the upraising table			

* Increased max lift capacity upon request

EXAMPLE CONFIGURATION 1-TABLE SOLUTION

SEPARATE UPRAISER BS10U

BS20 1-table solution is used when producing open panels, curtain walls or other open component (floor, roof).

POSITION A (OPERATIONS: BUILD FRAMEWORK, BOARD NAILING)

Hole Beams BS2HBL as an option adding flexibility in production of building elements less than 2250 mm in height or when producing angled shaped walls etc. Alignment function, Hydraulic Squaring BS2HC or Pneumatic Squaring BS2CR. Extended Width Adjustment BS2IW in production of elements higher than 3100 mm (< 3650 mm). The Vertical Outfeed of Wall Elements RS2RVP is used when the walls shall be fed from the machine in vertical position.

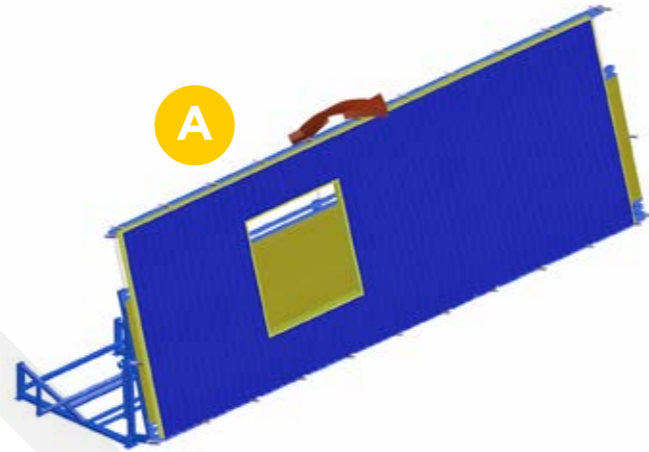

EXAMPLE CONFIGURATION 2-TABLE SOLUTION

STANDARD BS20-SYSTEM

BS20 2-table solution is the standard original layout that is used by producer throughout the world. In this station it is possible to produce insulated walls, floors and roofs.

POSITION A (OPERATIONS: BUILD FRAMEWORK, BOARD NAILING)

Hole Beams as an option adding flexibility in case of production of building elements less than 2250 mm in height or when producing angled shape walls etc. As clamping system Hydraulic Squaring or Pneumatic Squaring. Extended Width Adjustment in case of production of elements higher than 3100 mm (< 3650 mm).

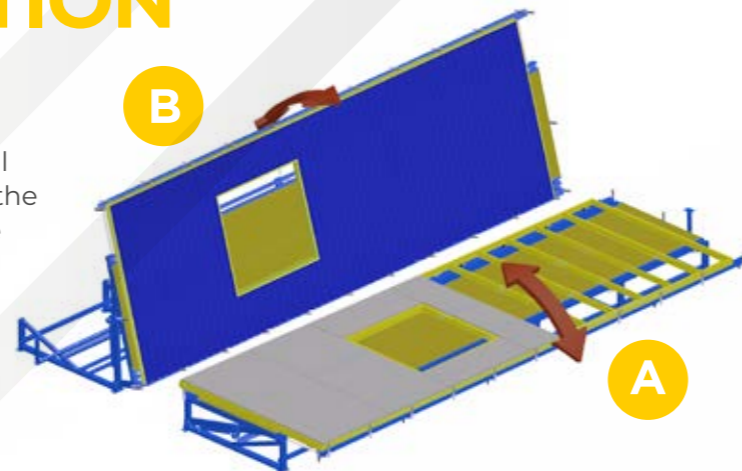

POSITION B (OPERATIONS: INSULATION, BOARD/CLADDING NAILING)

The Vertical Outfeed of Wall Elements is used when the walls shall be fed from the machine in vertical position.

EXAMPLE CONFIGURATION 3-TABLE SOLUTION

BS20 WITH EXTRA STATION

In this 3-table solution the working processes after turning, which in general is more time demanding than the working processes before turning, has been divided into 2 stations in order to increase the capacity. In this line it is possible to produce insulated walls, floors and roofs.

The system can be configured with an adjustable transport system of alignment function Rollers or Fixed Rollers. Rollers (page 11) must be used in the first station where the framework is built. As clamping system Hydraulic Squaring or Pneumatic Squaring. Extended Width Adjustment in case of production of elements higher than 3100 mm (< 3650 mm).

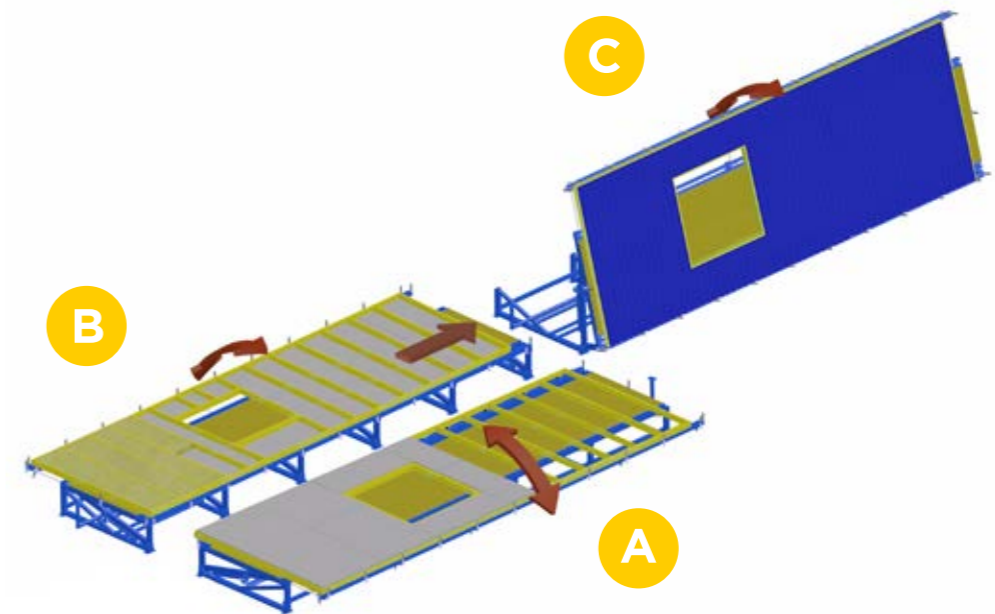

POSITION A (OPERATIONS: BUILD FRAMEWORK, BOARD NAILING)

Hole Beams as an option adding flexibility in case of production of building elements less than 2250 mm in height or when producing angled shape walls etc. In order to be able to transport elements less than 2250 mm in height after turning the stations needs to have a "third" roller conveyor.

POSITION B (OPERATIONS: INSULATION, BOARD NAILING)

Upraisable Roller (3 rows) or Fixed Roller (3 rows) to be able to transport elements less than 2250 mm in height.

POSITION C (OPERATIONS: NAILING OF CLADDING ETC)

The Vertical Outfeed of Wall Elements is used when the walls shall be fed from the machine in vertical position.

EXAMPLE CONFIGURATION

4-TABLE SOLUTION

BS20 WITH FRAMING STATION AND EXTRA STATION

Here we have solution consisting of 4-tables forming a production line. We fully utilize the effectiveness achieved by producing in a line. In this line it is possible to produce insulated walls, floors and roofs.

station where the framework is built. As clamping system Hydraulic Squaring or Pneumatic Squaring. Extended Width Adjustment in case of production of elements higher than 3100 mm (< 3650 mm).

The system can be configured with a transport system with Upraisable Rollers or Fixed Rollers. Rollers (page 11) must be used in the first

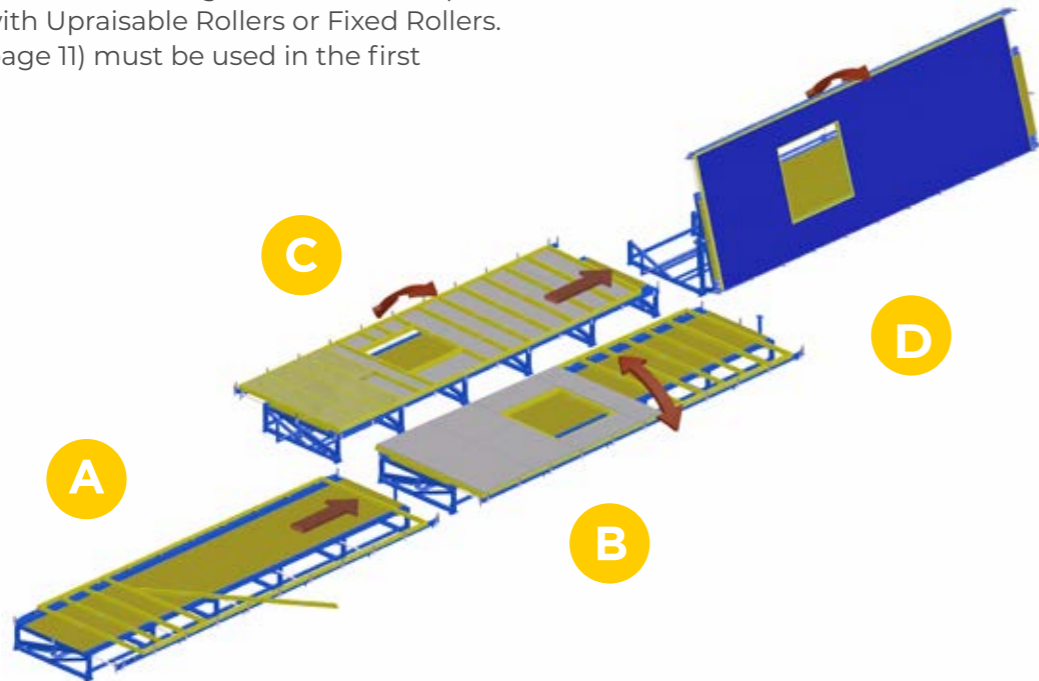

POSITION A (OPERATIONS: BUILD FRAME WORK)

Hole Beams BS2HBL as option adding extra flexibility i.e. when producing angled shape walls etc.

POSITION B (OPERATIONS: BOARD NAILING)

Hole beams is listed as an option also in this station in case of production of building elements less than 2250 mm in height. When producing these small elements this station (B) will act as the first station. In order to be able to transport the element after turning the stations needs to have a "third" roller conveyor.

POSITION C (OPERATIONS: INSULATION, BOARD NAILING)

Upraisable Roller (3 rows) BS2RL3 or Fixed Rollers (3 rows) BS2FR3 to be able to transport elements less than 2250 mm in height.

POSITION D (OPERATIONS: NAILING OF CLADDING ETC)

The Vertical Outfeed of Wall Elements RS2RVP is used when the elements shall be fed from the machine in vertical position.

EQUIPMENT AND FUNCTIONS IN THE EXAMPLE CONFIGURATIONS

Below are functions for the example configurations listed. BS20 is developed as a flexible module based system where the options can be added to fit the production of each customer.

Option	Model	Page		1-table solution				2-table solution			3-table solution			4-table solution				
				A	B	C	D	A	B	C	A	B	C	D	A	B	C	D
<input checked="" type="checkbox"/> Chosen option <input type="checkbox"/> Other recommended options <input type="checkbox"/> Possible options <input type="checkbox"/> Options not allowed in this configuration																		
Hydraulic Turning - 90 degrees	BS2-T9	12	One choice	❌	✅	✅	❌	✅	✅	❌	❌	❌	❌	❌	❌	❌	❌	❌
Hydraulic Turning - 80 degrees	BS2-T8	12	One choice	✅	❌	❌	❌	❌	❌	❌	❌	❌	❌	❌	❌	❌	❌	❌
Fixed Rollers (2 rows)	BS2-FR2	11	One choice															
Fixed Rollers (3 rows)	BS2-FR3	11																
Upraisable Rollers (2 rows)	BS2-RL2	11																
Upraisable Rollers (3 rows)	BS2-RL3	11																
Manual Width Adjustment (no squaring)	BS2-MW3100	14	One choice															
Manual Width Adjustment Pneumatic Squaring	BS2-MW3100P	14		✅														
Extended Manual Width Adjustment Pneumatic Squaring	BS2-MW3650PS	14		❌														
Hydraulic Width Adjustment and Squaring	BS2-HW3100HS	14		❌														
Extended Hydraulic Width Adjustment and Squaring	BS2-HW3650HS	14																
C-bars, Across	BS2-C	13																
Hole Beams, Across	BS2-HBL	13																
Hole beams, Short side	BS2-HBC	13																
Outfeed of Wall Element	BS2-RVP	16																
Air Supply Pneumatic Tools	BS2-XA	17																

CONFIGURE YOUR BUTTERFLY TABLE

Detailed description of each function follows on the next pages in this brochure. Read through the descriptions in detail and chose the functions fitting your production, feel free to ask a Randek representative for assistance.

The base in the BS20-system is a standard machine that can be equipped with many different options and add-ons. The standard machine is built as an upraiser, receiver or a working table without hydraulic turning function in length 6.0, 7.5, 9.0 and 12.0 m. All options are possible to add to the standard machines and are available in the mentioned length steps.

Basic machine	Model	Station length
Upraiser Table	BS10U-060	6000 mm
Upraiser Table	BS10U-075	7500 mm
Upraiser Table	BS10U-090	9000 mm
Upraiser Table	BS10U-120	12000 mm
Receiver Table	BS10R-060	6000 mm
Receiver Table	BS10R-075	7500 mm
Receiver Table	BS10R-090	9000 mm
Receiver Table	BS10R-120	12000 mm
Working Table	BS05-060	6000 mm
Working Table	BS05-075	7500 mm
Working Table	BS05-090	9000 mm
Working Table	BS05-120	12000 mm

To configure a receiver or upraiser you need – besides the basic machine – to choose hydraulic turning (page 12) and the horizontal transport option (page 11). For Working Table the horizontal transport option needs to be chosen (page 11).

HORIZONTAL TRANSPORT OF ELEMENT

ROLLERS FOR TRANSPORT OF ELEMENTS IN HORIZONTAL POSITION ENABLES PRODUCTION LINES WITH BS20 SYSTEM.

All tables can be equipped with rollers for transport of elements in horizontal position. The rollers can be fixed or upraisable. The rollers are placed on top and bottom plate of the element in order not to damage the element. The roller system consists of two rollers whereof one is placed on the width adjustment function to be able to position on the top plate for all element widths.

The transport of the building element is easily done by manually pushing the element forward. It is also possible to place an extra roller on the middle of the table. The purpose of this extra roller is to be able to transport building elements lower than 2250 mm in width after being turned, the elements needs to be covered with boards (see 3- or 4-table solution in the example layouts).

- Rollers for effective transport of building element in horizontal position
- Fixed or upraisable rollers
- Take advantage of the effectiveness benefits by producing in line with BS20 system



FUNCTION DESCRIPTION UPRAISABLE ROLLERS

- Build the timber frame work efficiently and qualitatively using the squaring function.
- Raise the rollers and push the element forward to the next station
- Lower the rollers

HYDRAULIC TURNING

SAFE AND EFFECTIVE TURNING OF BUILDING ELEMENTS WITH THE HYDRAULIC TURNING FUNCTION.



BS10/20 tables are equipped with the hydraulic turning function. The upraise level is 90-degrees for turning function and 80-degrees for upraise function.

The turning/upraising is easily performed by the operator using a control unit placed separated from the tables. The turning function is performed by hydraulic cylinders fed from hydraulic unit.

- Safe, effective and non-damaging turning of walls/building elements
- Upraise or Turning function

FUNCTION DESCRIPTION TURNING FUNCTION

- The receiver table is raised to 90-degrees and then the upraise table is raised
- The receiver table is lowered and the building element is turned; safe, effective and non-damaging. The upraise table is lowered.
- The building element is finalized
- The receiver table is raised and the wall element is transported using a conveyor system or by using Vertical Outfeed of Wall Element.

FLEXIBLE SUPPORT

FLEXIBLE SUPPORT FOR BUILDING ELEMENTS USING C-BARS AND HOLE BEAMS.

To be able to produce building elements of almost any type and shape the BS20 system can be expanded with extra support features; C-Bars and Hole Beams.

C-BARS

C-bars make it possible to place support devices running in the C-bars, the standard configuration of the BS20-system has 2 C-bars running along the table on each side. To be used to indicate where to place studs etc, as option C-bars can be placed across the table.

HOLE BEAMS

Hole beams enables flexible support and clamping. In the hole beams the same support pins placed along the table can be placed, thus making it possible to produce building elements less than 2250 mm in width. It is also possible to place movable clamping cylinders for extra clamping function when producing i.e. angled shape building elements or when need for clamping from inside of the element towards the support pins. The hole beams are placed across the table or on the short side of the table for clamping towards the short side of the building element.



- Flexible clamping and support with C-bars and hole beams
- Enables production of short and angled shape building elements
- Extra pneumatic clamping from all angles





View showing hydraulic width and squaring function

WIDTH ADJUSTMENT AND SQUARING

EFFECTIVE PRODUCTION OF BUILDING ELEMENTS WITH THE SQUARING AND WIDTH ADJUSTMENT FUNCTION.

The squaring function clamps and straighten the timber frame work pneumatic or hydraulic to a 90-degree angled shape and eliminates bow shaped timber. The width adjustment function enables a flexible production where building elements with different widths can be efficiently produced.

SQUARING FUNCTION

The working table has 160 mm high support pins on all sides of the table whereof one long side is adjustable in width and can be equipped with pneumatic or hydraulic squaring function. It is the support pins that are pushed against the timber frame work, thus squaring it to a 90-degree shape and eliminating bow shaped timber. Both short sides of the table are also equipped with support pins.

WIDTH ADJUSTMENT FUNCTION

Flexibility is achieved by the width adjustment function. The adjustment of different widths on the building element (wall heights) is easily done from 2250 – 3100 mm, as option the interval can be extended 2250 – 3650 mm. Extended Width Adjustment expands the width adjustment to 3650 mm and Hole Beams makes it possible to lower the minimum width from standard 2250 mm to desired width (wall height). When using the pneumatic system the adjustment is done by releasing the width adjustment side and manually pulling it outwards. The hydraulic system does the adjustment automatically by activating the hydraulic system that is also used as squaring function.

FUNCTION DESCRIPTION

- The width (wall height) is set-up with the widths adjustment function, manually for pneumatic system and automatically for hydraulic system.
- Studs and top/bottom plates are placed on the table
- The building element is squared to 90-degree element and bow shaped timber is eliminated
- The timber frame work with boards is nailed fixating the squared 90-degree element
- The squaring function is deactivated and the building element is turned or transported further depending on configuration of total system

3D-view of the manual width adjustment with pneumatic squaring

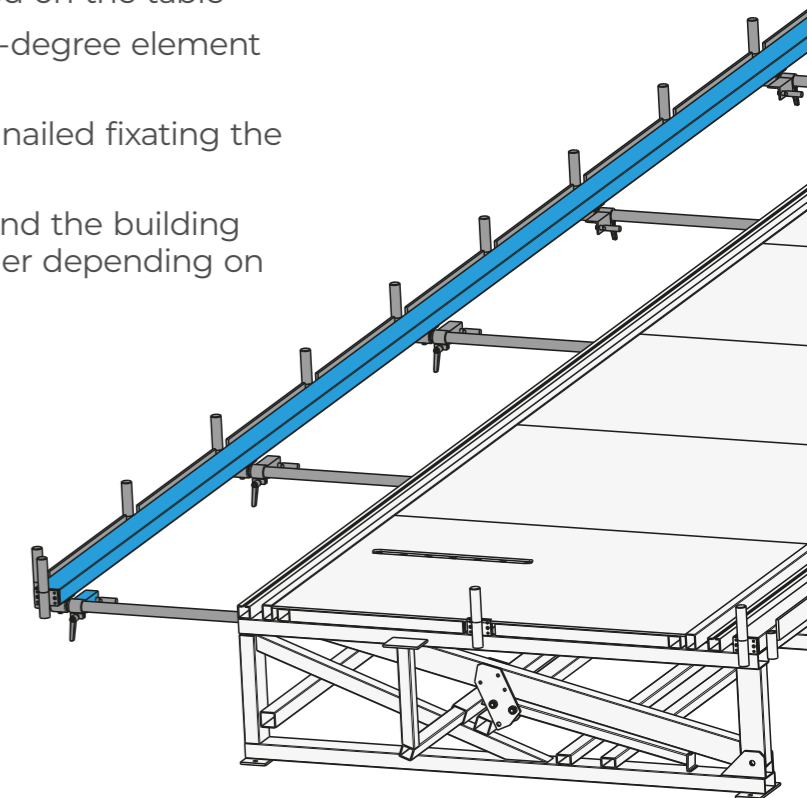

OUTFEED OF WALL ELEMENT

OUTFEED OF WALL ELEMENT IN UPRaised POSITION FOR EFFECTIVE PRODUCTION, HANDLING AND STORAGE.

The upraise table has support pins equipped with rollers enabling outfeed of wall element in upraised position. The wall element is fed out from the upraise table on to wall wagons placed on a rail or onto an outfeed track equipped with rollers, then further to a working station (alternatively fed directly to a stock system) where manual processes such as window mounting, stucco etc. can be performed. Processes that are done more effective when the wall is in a standing position, increasing productivity in the house factory.



- Outfeed of wall element in upraised position.
- No (less) need for conveyor
- When in storage / working area, it is possible to perform working processes.

FUNCTION DESCRIPTION

- The wall is erected with an upraise table to vertical position
- The wall is fed out in vertical position on support pins equipped with rollers further to adjacent wall wagons placed on a rail alternatively to an outfeed track equipped with rollers
- The wall element is placed on a vertical storage system. Suitable manual processes such as window mounting, electrical installations, stucco, painting can be performed.

Option				Model
6 meter	7,5 meter	9 meter	12 meter	
118969AA	118969AB	118969AC	118969AD	Vertical Outfeed of Wall Element
WAR1-D80-060	WAR1-D80-075	WAR1-D80-090	WAR1-D80-012	Working/ storage area 80 °
				WAR1

AIR SUPPLY FOR PNEUMATIC TOOLS

CONNECT PNEUMATIC TOOLS DIRECTLY ON THE WORKING TABLE FOR EFFECTIVE PRODUCTION.

2 pcs of air supply placed at the centre of the long sides of the working tables. Pneumatic tools can be connected directly to the table minimizing loose air hoses on the production floor; the time for connecting pneumatic tools is also minimized.

- Connect pneumatic tools directly to the working tables
- Minimize air hoses on the production floor
- Effective production



Option				Model
6 meter	7,5 meter	9 meter	12 meter	
118970AA	118970AB	118970AC	118970AD	Air Supply for Pneumatic Tools
				BS2-XA

ACCESSORIES

TO RANDEK BS20 SYSTEM THERE ARE A NUMBER OF ACCESSORIES AND EQUIPMENT THAT CAN BE INTEGRATED TO THE TABLES AND PRODUCTION LINES.

Name	Model	Description
Clamping Cylinder	BS3-CC	Placement in hole beam, Press force 1870 N at 6 bar.
Round Support	BS2-S	Support for C-bars
Foil Holder	HFM002-High	Length: 3700 mm, Height: 850-1350 mm
Foil Holder	HFM002-Low	Length: 3700 mm, Height: 450-600 mm
Material table	MHT001	Table for handling of building material
Material Element Trolley	LMW001	Trolley for smaller components

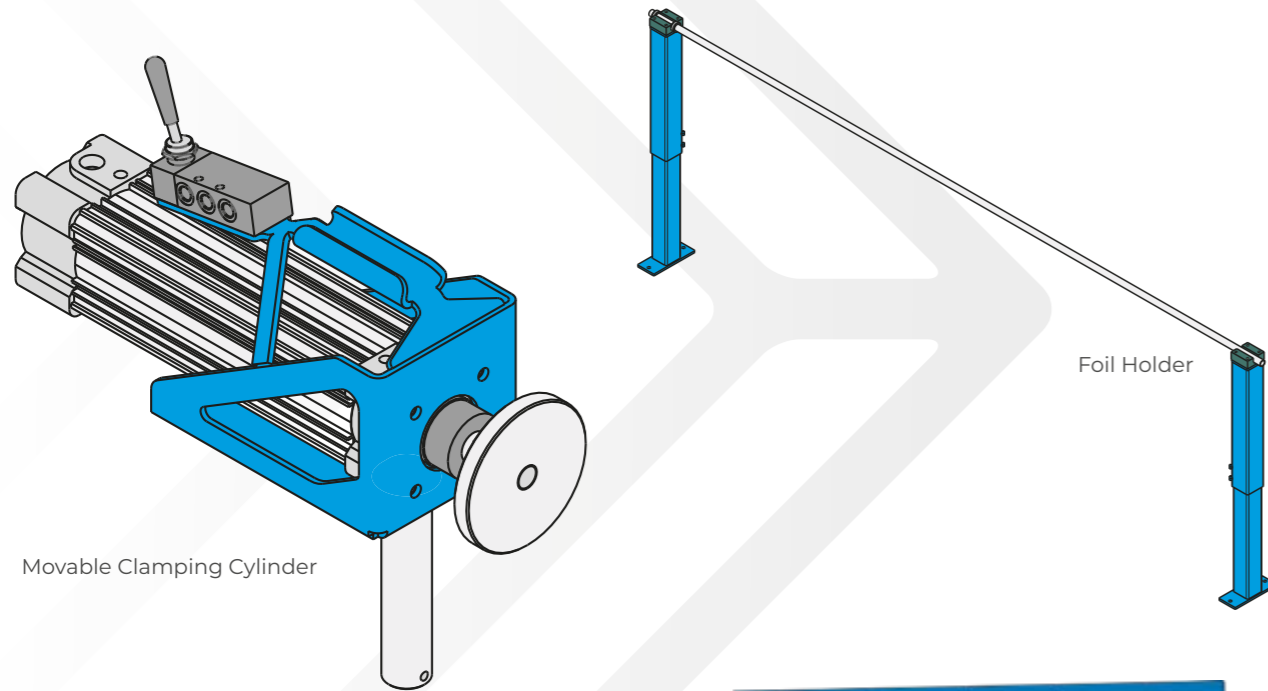

SWEDISH QUALITY LASTS

Randek are pioneers in creating innovative automation solutions for customers within the prefabricated house manufacturing industry since the 1940s. Today, Randek is one of the world's leading suppliers of high-performance machines, robotic solutions and complete systems with production lines holding several world records in production capacity.

PRODUCTS/SYSTEM



CUT SAWS

Sturdy reliable cut saws delivered to house and roof truss manufacturers all over the world. From manual to fully automated



WALL, FLOOR AND ROOF PRODUCTION LINES

A comprehensive product range with tailor-made systems for prefab manufacturing of walls, floors and ceilings. From manual to fully automated.



ROBOTIC SYSTEM

Randek Robotics develop advanced systems in robotic automation. Delivering efficiency to customers in Europe, China, North and South America since the 1990s.



ROOF TRUSS SYSTEM

Equipment for traditional and effective manufacturing of roof trusses and a revolutionising automated roof truss production system.



BUTTERFLY TABLES

Innovative wall-turning tables. From moderate manual wall-turning tables to advanced with a range of options.

RANDEK SERVICES



PRESTUDY



MAINTENANCE



GLOBAL SUPPORT



FINANCIAL SOLUTIONS

Randek is not liable for any misprints or errors in this catalogue