

Vertical CNC Processing Centers BHX 050/055 Optimat



2015/2016

BHX 050/055 – big can be that small...

Our CNC processing centers offer the technology of the future today. And with good reason: Tradition. For us, it is both a motivation and a commitment. Customers the world over associate the very highest standards with this. And we meet those expectations.



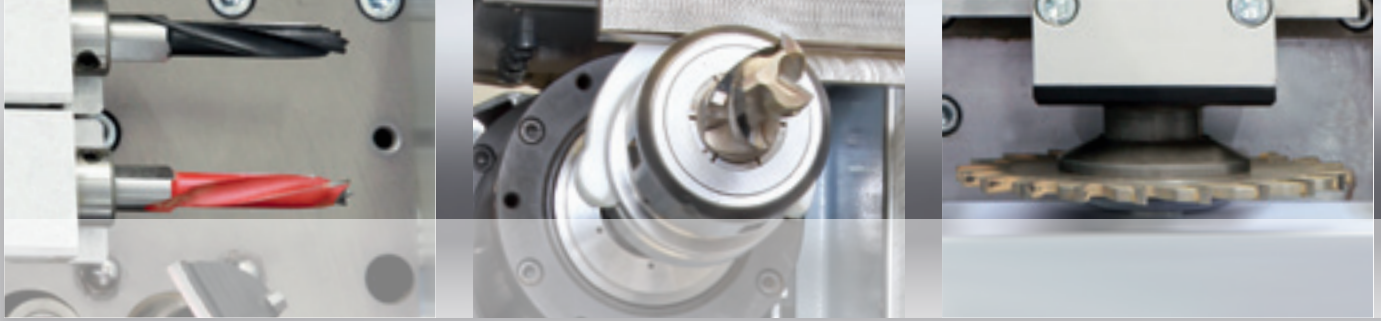

BHX 050/055 – the smart allrounders for drilling, routing, grooving!

- Fast processing – **saves time**
- Takes up little room – **saves space**
- Simple operation – **saves nerves**
- Great value for money – **saves money**



Content

- 4 BHX 050 Configuration
- 5 BHX 055 Configuration
- 6 All inclusive | power**Touch**
- 8 All inclusive | Hardware
- 10 Plausibility check
- 11 Length-dependent processing
- 12 Office-Package
- 14 Technical data
- 15 **ecoPlus** advantages

The Configurations



BHX 050

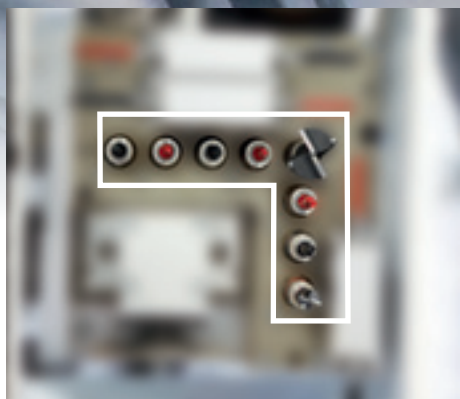
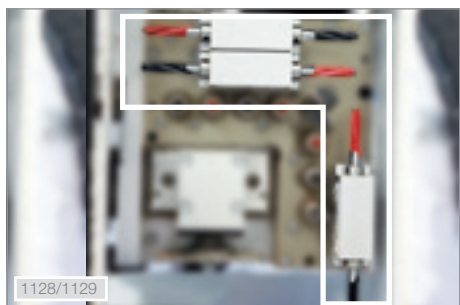

Fig. left: Standard configuration

- 8 vertical drilling spindles, incl. quick-change drilling system



1128/1129

Processing example

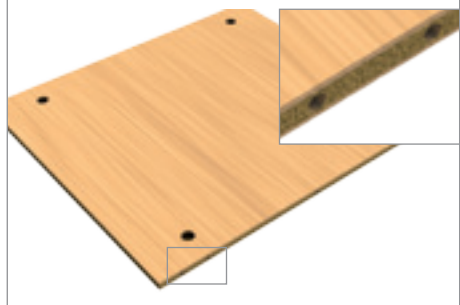

Option – horizontal drilling

- 4 High-speed drilling spindles in X-direction
- 2 High-speed drilling spindles in Y-direction

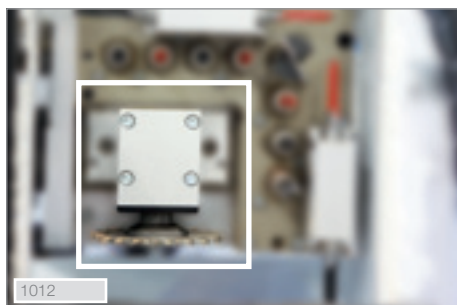

1012

Processing example

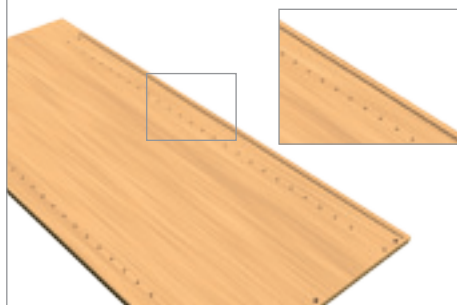

Option – grooving

- Grooving saw in X-direction, Ø 100 mm



1029

Processing example

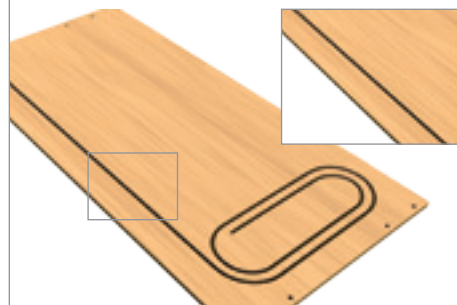

Option – routing

- Router motor with hydraulic quick change system, 5 kW ETP 25

Fig. right:
Example of configuration BHX 055

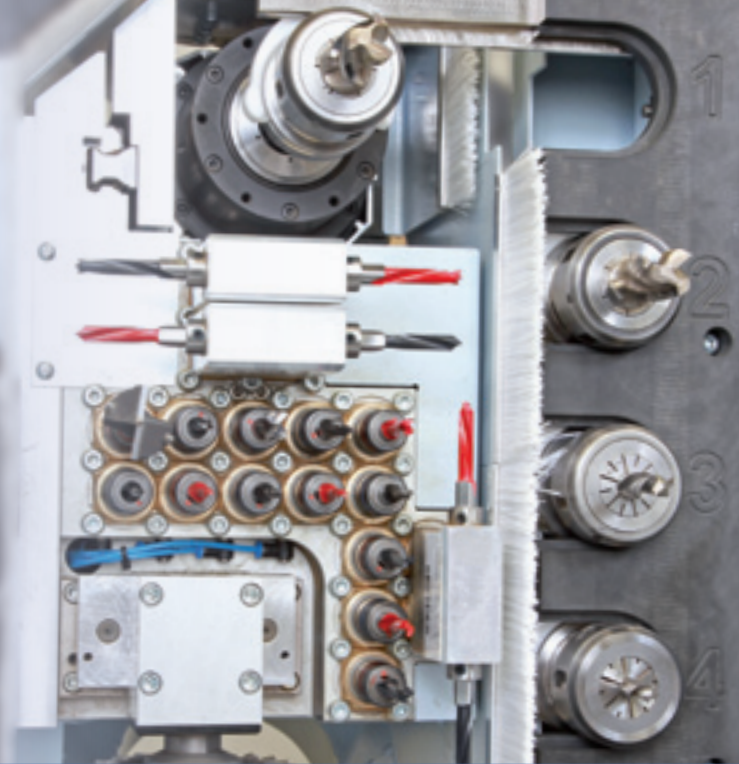

BHX 055



Fig. left: Standard configuration

- 13 vertical High-speed drilling spindles, incl. quick change drilling system

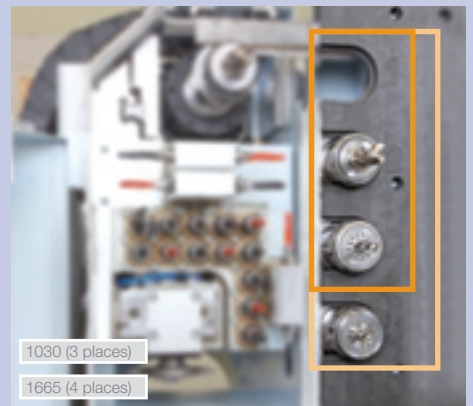
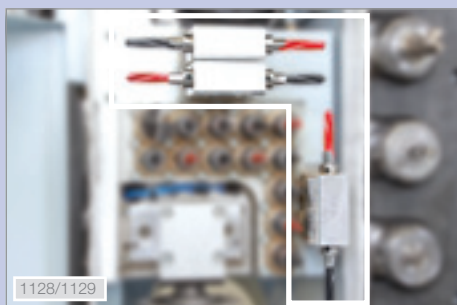

Fig. right: Optional tool changer

- Automatic tool change magazine with 3 places
- Extension of the tool change magazine by one place

1030 (3 places)

1665 (4 places)



1128/1129

Processing example

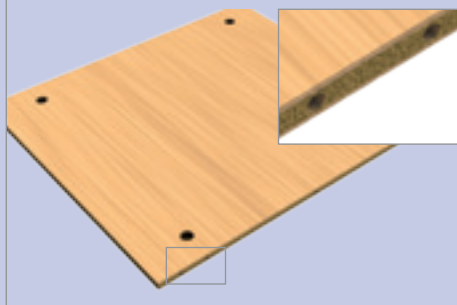

Option – horizontal drilling

- 4 High-speed drilling spindles in X-direction
- 2 High-speed drilling spindles in Y-direction

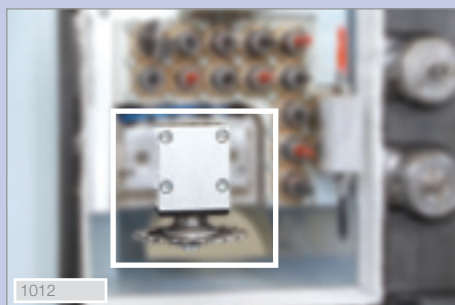

1012

Processing example

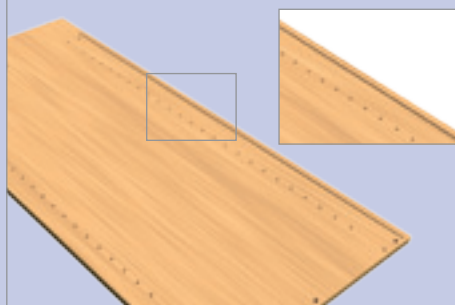

Option – grooving

- Grooving saw in X-Direction, Ø 100 mm

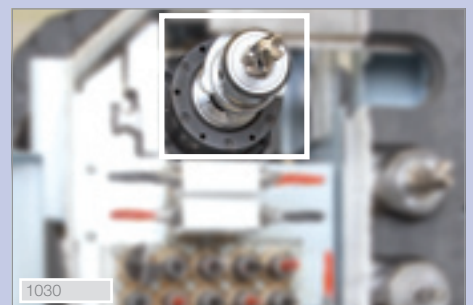

1030

Processing example

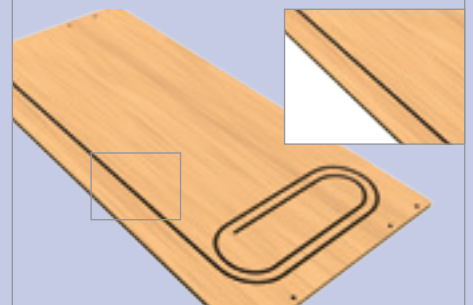

Option – routing

- Tool changing spindle 5 kW HSK 63

All inclusive | powerTouch

powerTouch is the latest operating philosophy of the HOMAG Group: Simple, uniform, ergonomic, evolutionary. The new system unites design with functionality in a totally new user interface.



At the focus of this solution is a large multi-touch monitor in widescreen format, which is used to control machine functions by direct touch contact. The entire user interface has been optimized for touch operation and offers an array of help and assistance functions designed to radically simplify the work experience. Standardized control elements and software modules

ensure that all HOMAG Group machines can be operated in the same way using powerTouch. They differ only in terms of a few machine-specific details.

This not only simplifies the operation of different machines, but also makes for greater efficiency by significantly reducing time for servicing and training.

powerControl with powerTouch

- 21,5" Full-HD multitouch display with wide screen 16:9
- USB frontside bus
- Ethernet connection 10/100 Mbit



woodWOP

- Modern software based on Windows®
- More than 30.000 installations worldwide

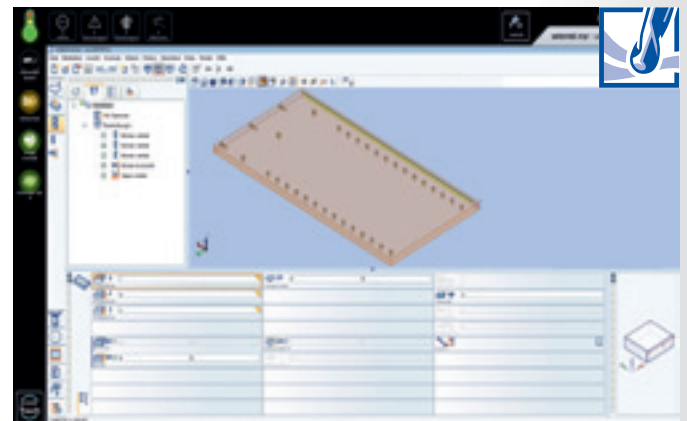

Machine Data Recording Basic

- Machine Data Recording – collecting and evaluating machine states via time meter and event meter



powerTouch | evolutionary, ergonomic, easy, equal



All inclusive | Hardware

The BHX 050/055-models provide a TOP equipment right from the beginning. As standard the machine already comprises elementary technologies ensuring a processing quality on highest level. Sustainability pays off...

High-Speed 7500

- Spindles with 1500 - 7500 RPM incl. the patented quick change system



Automatic spindle clamping system

- Patented system for exact drilling depth at any time with different materials

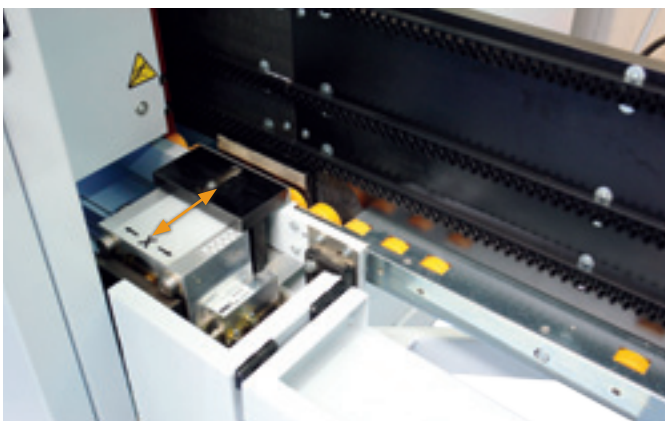
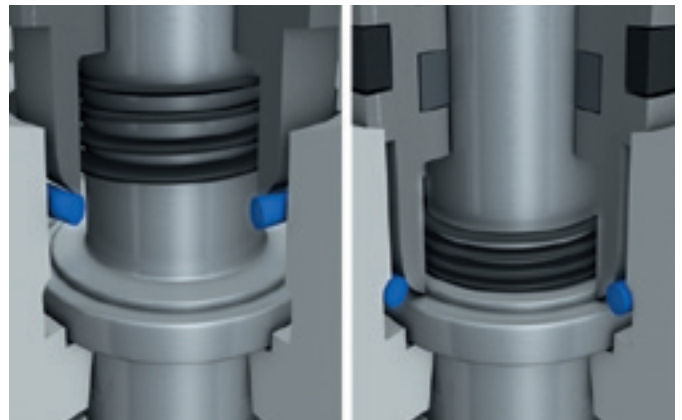

Workpiece clamping device

- Easy adjustment of the clamping device (manually) to the workpiece thickness (clamping device stroke 10 mm). For differences in the workpiece thickness of up to 10 mm it is not necessary to manually adjust the clamping device.

Pictures may also show options

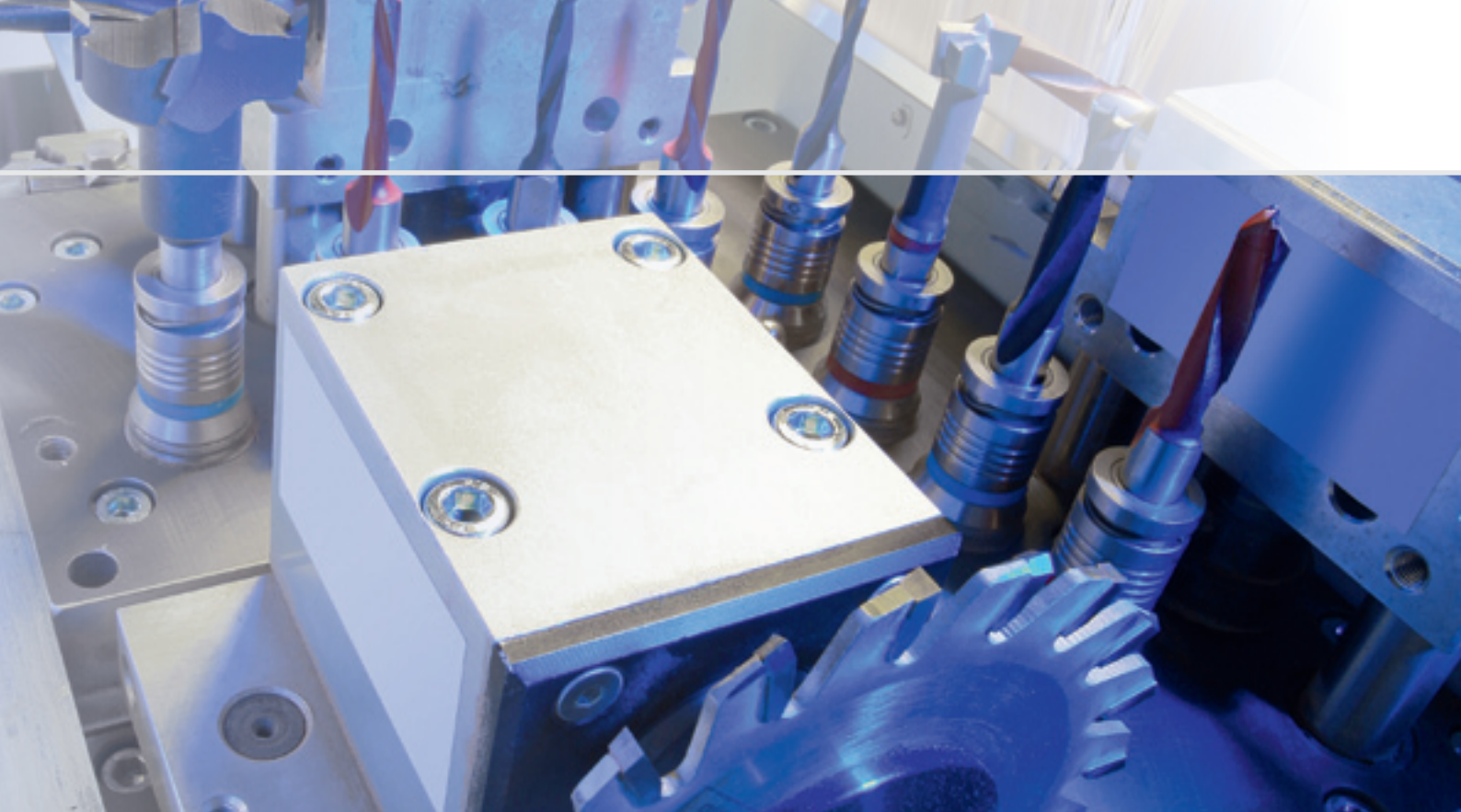

Workpiece load- and workpiece removal area

- Mechanical support via roller conveyor in the loading- and removal area of the machine.

Working length extension from 2500 mm to 3050 mm (BHX 050: Option / BHX 055: Standard)

- Extension of the working length to 3050 mm incl. roller conveyor

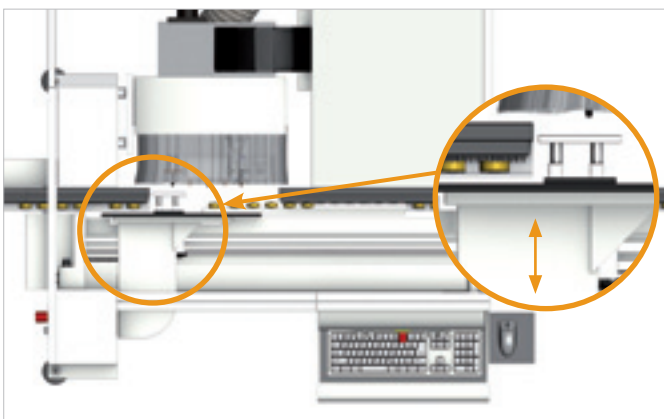

Automatic workpiece thickness adjustment

- Automatic adjustment of the counter block to the material thickness according to the data preselected by the operator in woodWOP



Option | Plausibility check

Benefit from additional safeguarding of processes

Control of the workpiece by sensor technology in X- and Y-direction. Comparison with the values in the database. If the defined tolerance value is exceeded, the current process stops. At the same time the operator receives a message to correct the workpiece. This way you remain on the safe side.

Step 1:

- Positioning the workpiece

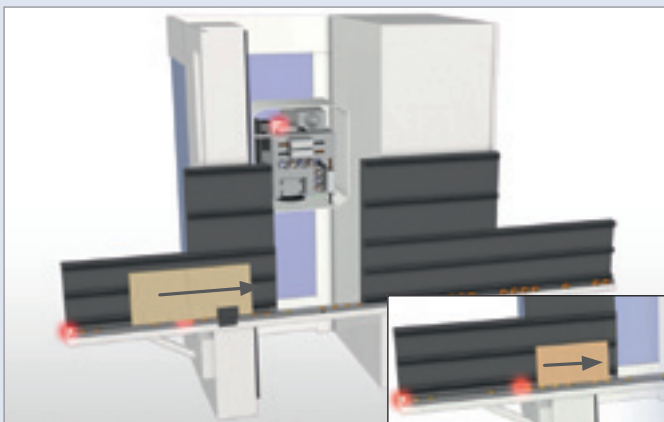

Step 2:

- Control of the workpiece by sensor technology in X-direction. Depending on the workpiece dimensions the shortest distance to the next sensor is selected.

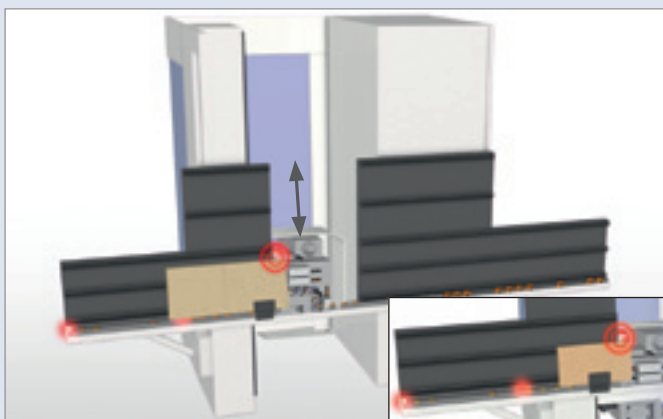
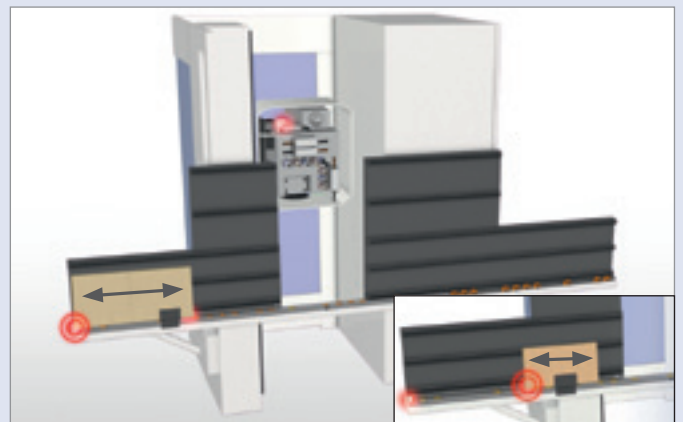

Step 3:

- Control of the workpiece by sensor technology in Y-direction

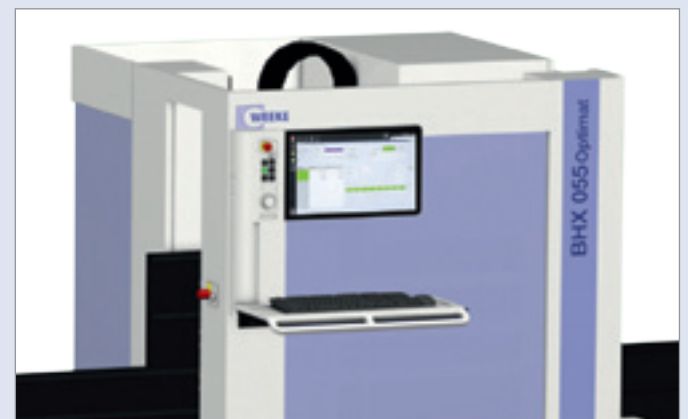

Step 4:

- Balancing the determined values with the program data:
Tolerance of values < 5 mm – Program is continued.
Tolerance of values > 5 mm – Program is stopped, advice to the operator to carry out the corrections.

Option | Length-dependent processing in X-direction

Automatic adjustment of drillings depending on workpiece dimensions

After the workpiece has been released for processing its length is measured accurately by a measuring run. Dimension-dependent drillings are then corrected automatically by possibly determined tolerances. You save time and gain quality.

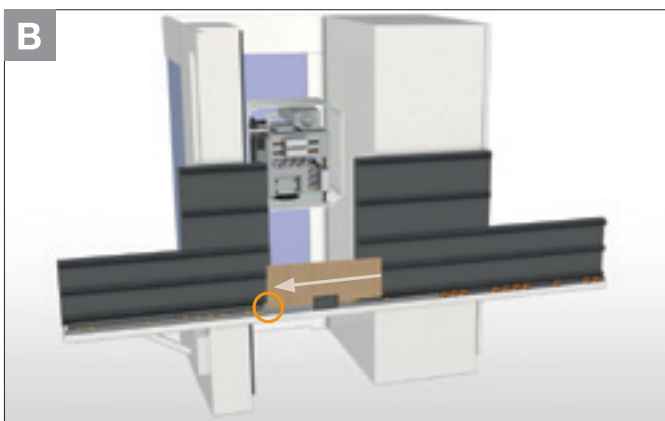
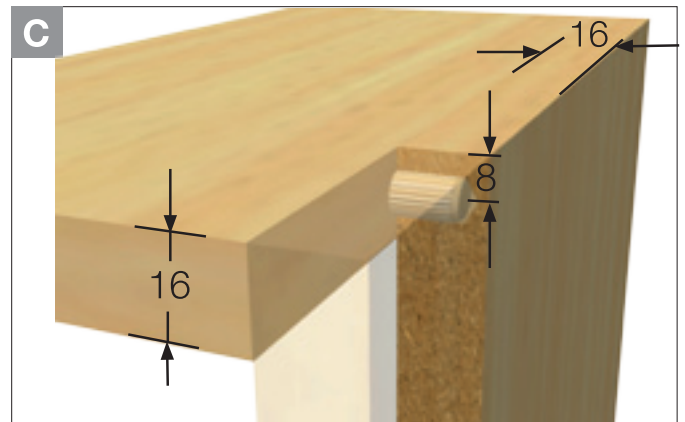
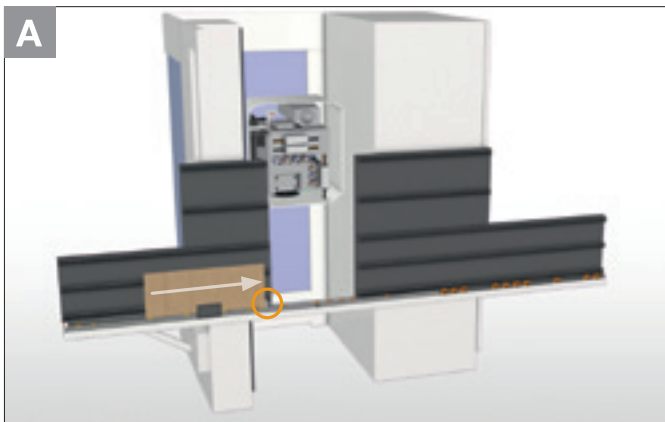

- A** After the workpiece has been released for processing at the limit stop position, a test run in X-direction is carried out (value 1).
- B** Determination of exact workpiece length (value 2).
- C** The calculation of the values 1 and 2 results in the exact workpiece length. Drills depending on dimensions are then automatically corrected by possibly determined tolerances.

Option | Office-Package

3D CNC-Simulator

- Simulates the processing in the order it is stored in the NC-program
- Allows time calculation

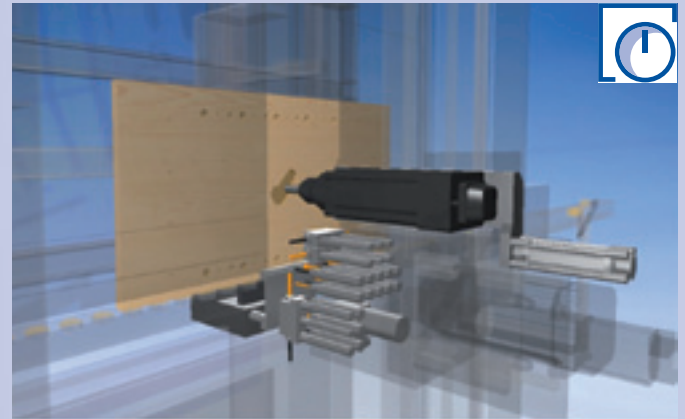

woodWOP

- Modern software based on Windows®
- More than 30.000 installations worldwide

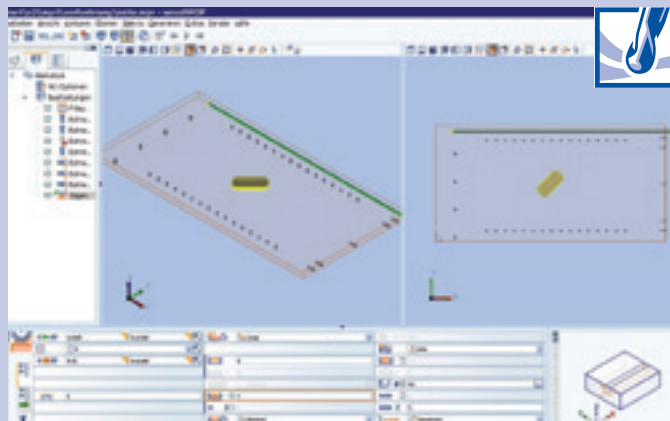

woodWOP DXF Basic

- Interface for CAD-Data Import
- Basis to generate woodWOP programs

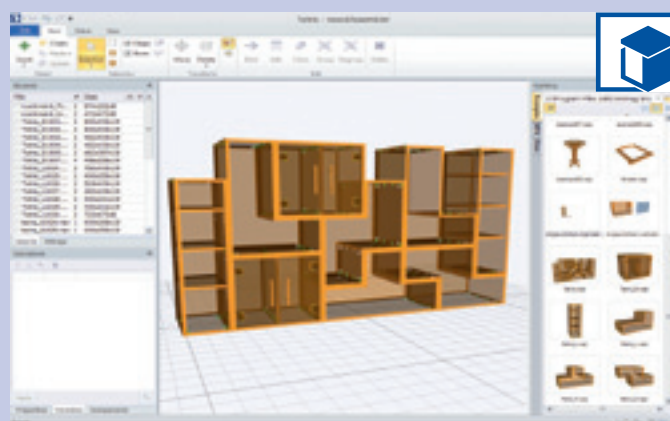

woodAssembler

- To visualize woodWOP-programs (MPR) in 3D
- Enables the construction of individual workpieces to finished objects

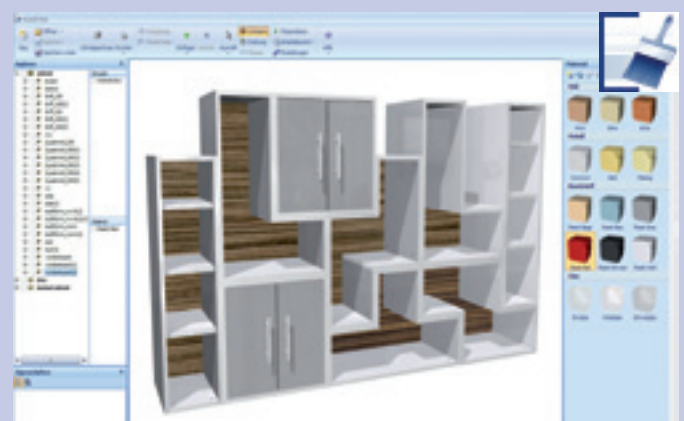

woodVisio

- Objects generated in woodAssembler or Blum Dynalog can be provided with a surface material
- The objects are displayed in a free-standing position



The magic
always lies
in the detail

Theodor Fontane

Always well positioned...

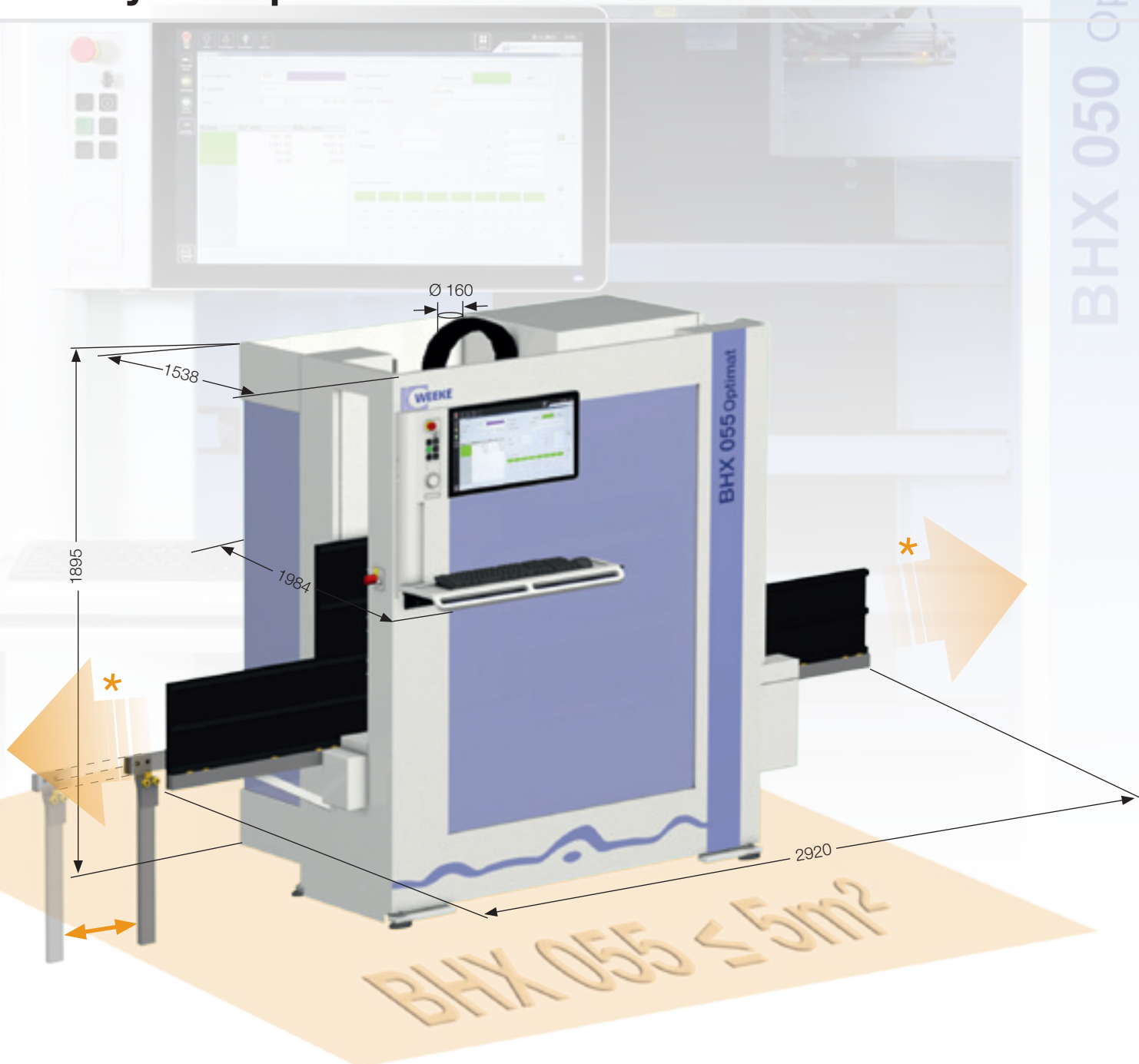

* A corresponding safety distance must be maintained in the in- and outfeed directions! (See documentation)

Dimensions in mm

Technical data BHX 050/055 Optimat

Workpiece dimensions **BHX 050 Optimat** L x W x T

mm

max. 2500 x 850 x 60 / option 3050
min. 200 x 70 x 12

Workpiece dimensions **BHX 055 Optimat** L x W x T

mm

max. 3050 x 850 x 60
min. 200 x 70 x 12

Vector speed

m/min

(X - Y) 50 - (Z) 15

Compressed air required

bar

7

Compressed air connection

inch

R 1/2

Dust extraction port

mm

Ø 160

Dust extraction volume

m³/h

min. 2170

Total machine weight

kg

approx. 1580

Electrical power – total connection load

kW

11,5



Saving **resources** Saving **money**



ecoPlus



BHX 050/055 with ecoPlus

- Low energy consumption (less than 10 kW) by efficient drive technology
- Workpiece clamping without vacuum as well as low compressed air consumption
- Efficient extraction – overall extraction output max. 2170 m³/h

Savings of time, material, energy and installation space ensure:

- Potentials to apply for subsidies
- Potentials for alternative investments
- Potentials to increase your profitability
- Potentials for own marketing communication regarding environmentally conscious partnership



**Choose the Original
Choose Success!**

For the Success of Original Technology
A campaign of the VDMA



You may contact us – WORLDWIDE

- Teleservice possibility via basic internet connection (TSN possibility)
- Competent spare parts service
- WEEKE Communication: Up-to-date information at all times:
www.weeke.com
- Any questions, new ideas, criticism & praise to: **info@weeke.de**

Member of the HOMAG Group



WEEKE Bohrsysteme GmbH

Benzstrasse 10-16
33442 Herzebrock-Clarholz
GERMANY

Tel.: +49 5245 445-0
Fax: +49 5245 445-44 139
info@weeke.de
www.weeke.com