

# **BIESSE SKIPPER 130**

NC processing centre



When competitiveness  
means zero  
adjustments and  
zero downtime



Made In Biesse

## The market requires

a change in production processes to meet the increasing demand for **customer specific products whilst maintaining quick and defined delivery times.**

## Biesse responds

with technological solutions able to meet the requirements of contract manufacturers, notably reducing their production costs. **Skipper 130** is an NC processing centre that allows the processing of panels of completely different formats in sequence, and without interruptions. It's ideal for the non-standard production of large companies, for producing small batches for third parties, and for those requiring just-in-time flexible production.

- 
- ✓ **Processes in real time, without interruptions or any need for manual interventions**
  - ✓ **High productivity, thanks to the complete and simultaneous machining of 2 panels (on all 6 panel faces)**
  - ✓ **Maximum performance for every function, whether boring or dowelling**
  - ✓ **User-friendly.**



# Personalisation in real time



**SKIPPER 130**  
NC processing centre





# Processing of different shapes in sequence

**Skipper 130 is revolutionary. It can machine all 6 panel faces simultaneously in one single step (including dowel insertion).**



Complete flexibility for machining panels of different thicknesses and sizes. Simultaneous, continuous machining operations on both the upper part and the lower part, without the need to feed the panels through the machine several times.

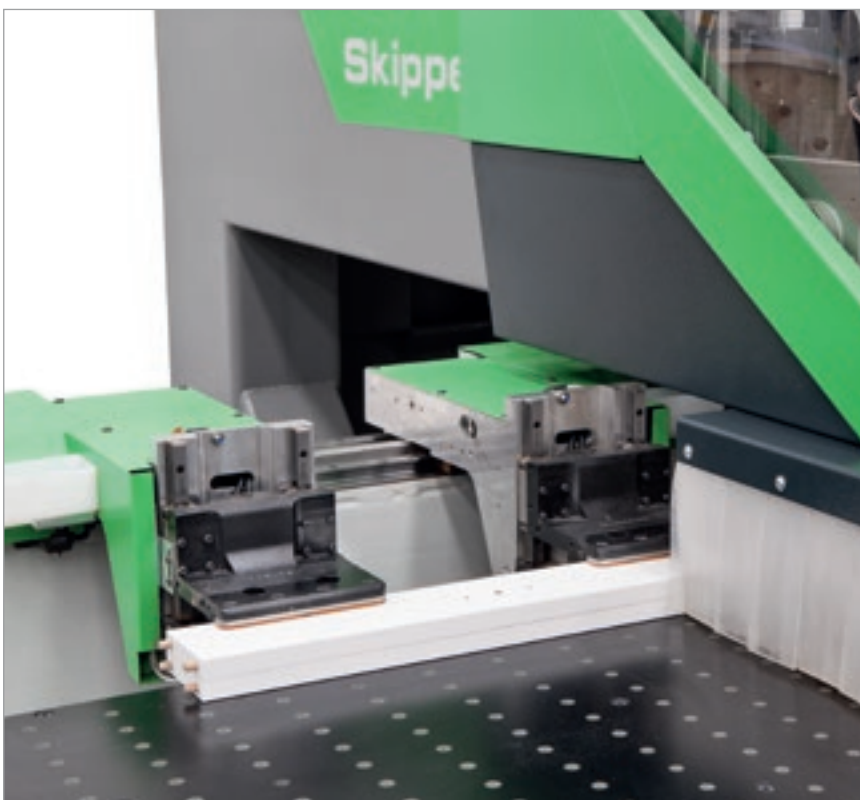

Skipper can easily perform "through" operations without any risk of splintering the material. It also processes "breathable" materials and very small pieces perfectly.



Maximum hold on panels of any material and shape, thanks to the panel clamping system using automatically positioned vices.



To start, you just need the work program; no tools, adjustments or tests are necessary because the panel is clamped using automatically positioned vices.



The 41+ 41 independent spindles guarantee first class performance.

Easy, quick tooling of both units.

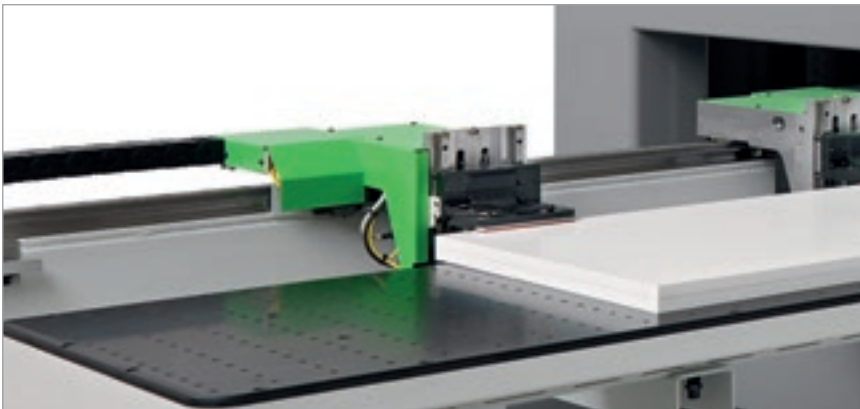

The piece size measuring system verifies the exact thickness of the panels in real time, automatically adjusting the machining depth as necessary.



Automatic repositioning of the vices during the machining operation.

No need for tooling operations or additional adjustments:  
Skipper 130 is always ready for use.

# Immediate productivity

A close-up photograph of a machine's air supply connection. It shows a metal fitting with a brass-colored tip and a silver-colored body, connected to a grey hose with an orange band. The background is a blurred industrial setting.

2 powerful opposing operating sections with 41+41 independent spindles machine 2 overlapping panels simultaneously, thereby doubling productivity levels. Skipper moves the panels in X and Y on an air cushion surface, in relation to the fixed tools. The panels move between two air cushions, processing one single panel or 2 mirrored panels simultaneously.

## REAL-TIME MACHINING

Long term reliability and precision. Material transformation cost reduction of over 60%. Maximum yield for batch 1 production. Easy use for everyone. A perfect combination of Biesse technology and Italian genius.





# Maximum performance for every function

Full panel customisation with borings, horizontal milling, channels and scoring.

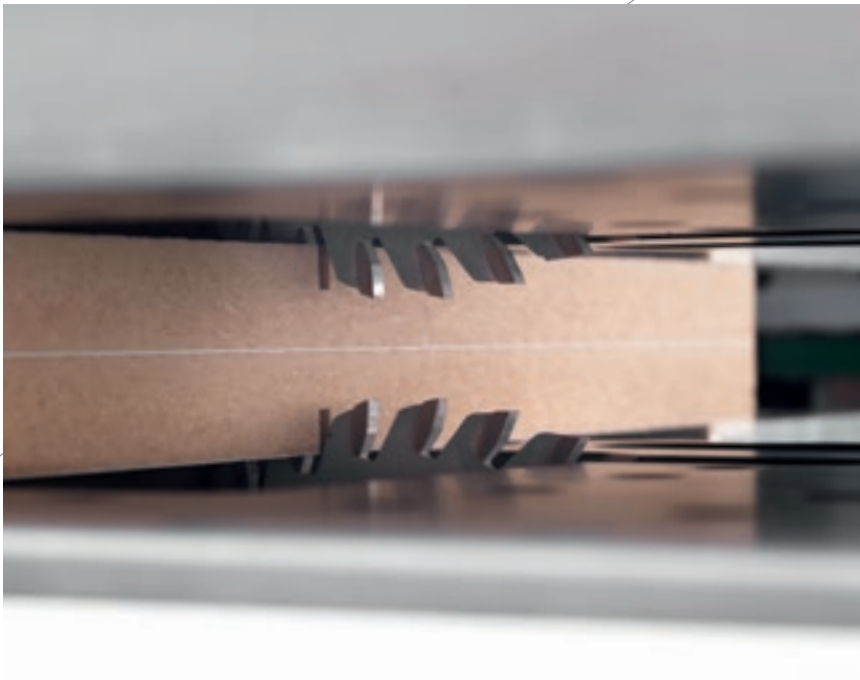

Blade units indexed 0-90° in the X and Y direction.



Blade units for milling operations and channels in the X direction.



Electrospindles with ISO30 coupling for changing the milling tools quickly and easily.



**Boring and horizontal milling on the 6th side.**



**The machine can be fitted with one or two independent horizontal units.**

# Full customisation

The panel emerges finished and fully machined, complete with dowels and therefore ready to be assembled or packed.

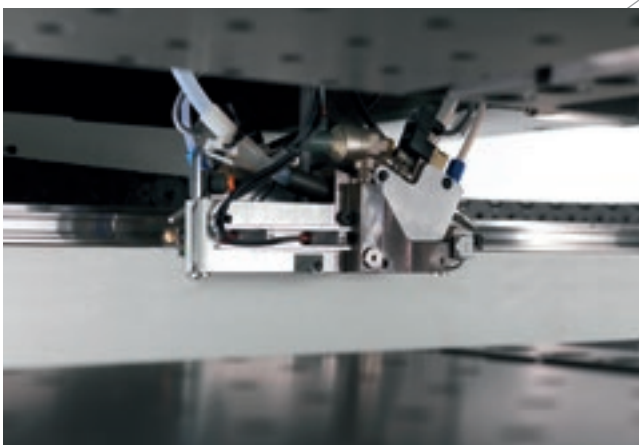

System of glue injection and dowel insertion with two opposing units, for machining the two ends of the panel.





# Integration in line processes



Reduced loading times, thanks to the system that automatically positions the panels up against the stops.

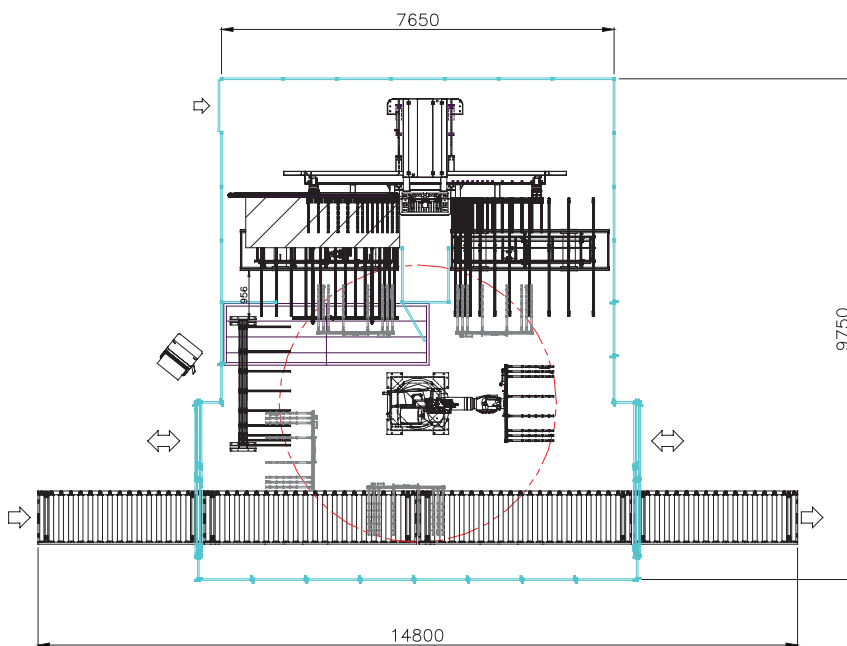

Skipper 130 can easily be integrated in a cell with a robot or with automatic loading/unloading systems.

# Service & Parts

Direct, seamless co-ordination of service requests between Service and Parts. Support for Key Customers by dedicated Biesse personnel, either in-house and/or at the customer's site.

## Biesse Service

- ✓ Machine and system installation and commissioning.
- ✓ Training centre dedicated to Biesse Field engineers, subsidiary and dealer personnel; client training directly at client's site.
- ✓ Overhaul, upgrade, repair and maintenance.
- ✓ Remote troubleshooting and diagnostics.
- ✓ Software upgrade.

500 / Biesse Field engineers in Italy and worldwide.

50 / Biesse engineers manning a Teleservice Centre.

550 / Certified Dealer engineers.

120 / Training courses in a variety of languages every year.



The Biesse Group promotes, nurtures and develops close and constructive relationships with customers in order to better understand their needs and improve its products and after-sales service through two dedicated areas: Biesse Service and Biesse Parts.

With its global network and highly specialised team, it offers technical service and machine/component spares anywhere in the world on-site and 24/7 on-line.



## Biesse Parts

- ✓ Original Biesse spares and spare kits customised for different machine models.
- ✓ Spare part identification support.
- ✓ Offices of DHL, UPS and GLS logistics partners located within the Biesse spare part warehouse, with multiple daily pick-ups.
- ✓ Order fulfilment time optimised thanks to a global distribution network with de-localised, automated warehouses.

87% / of downtime machine orders fulfilled within 24 hours.

95% / of orders delivered in full on time.

100 / spare part staff in Italy and worldwide.

500 / orders processed every day.

# User-friendly

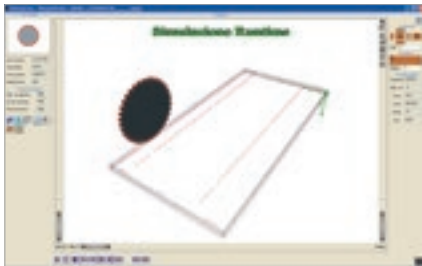

An extremely powerful yet user-friendly operator interface that allows quick decisions and automatically optimises the cycle on the basis of the tools available, to minimise work times.

BiesseWorks is the system for programming Biesse machines, combining high performance with remarkable ease of use. The interface can be customised to meet to user requirements.

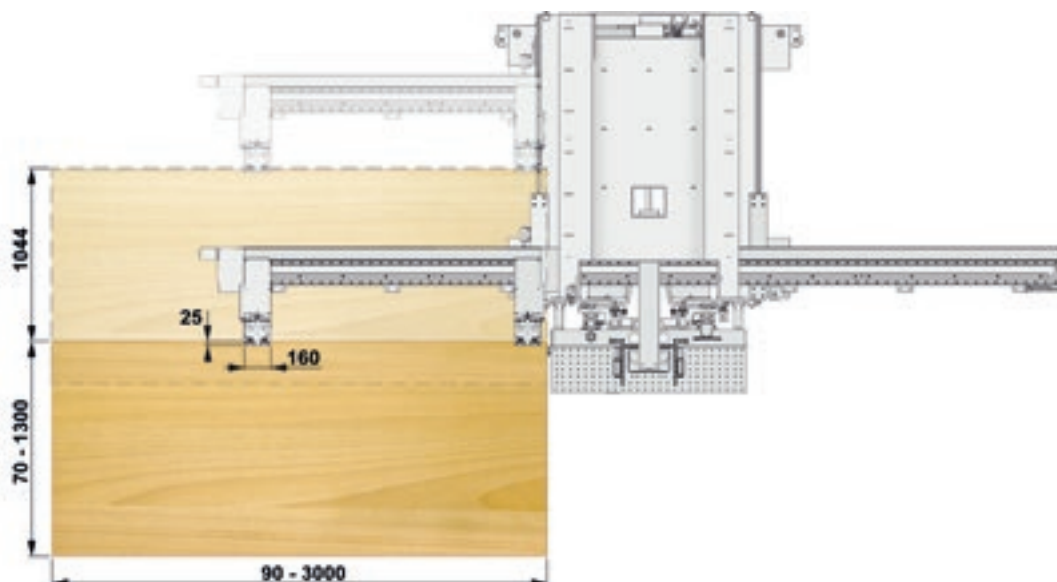
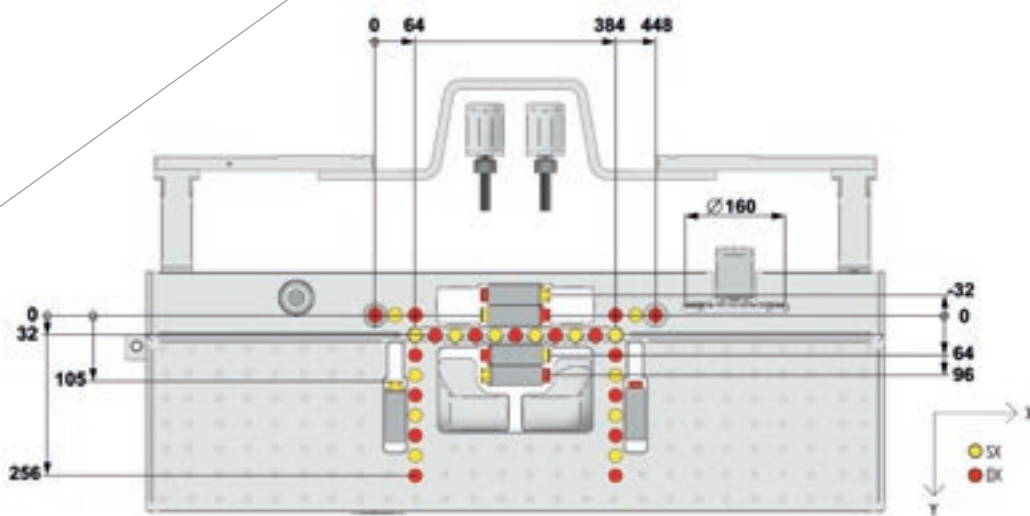

# Technical specifications

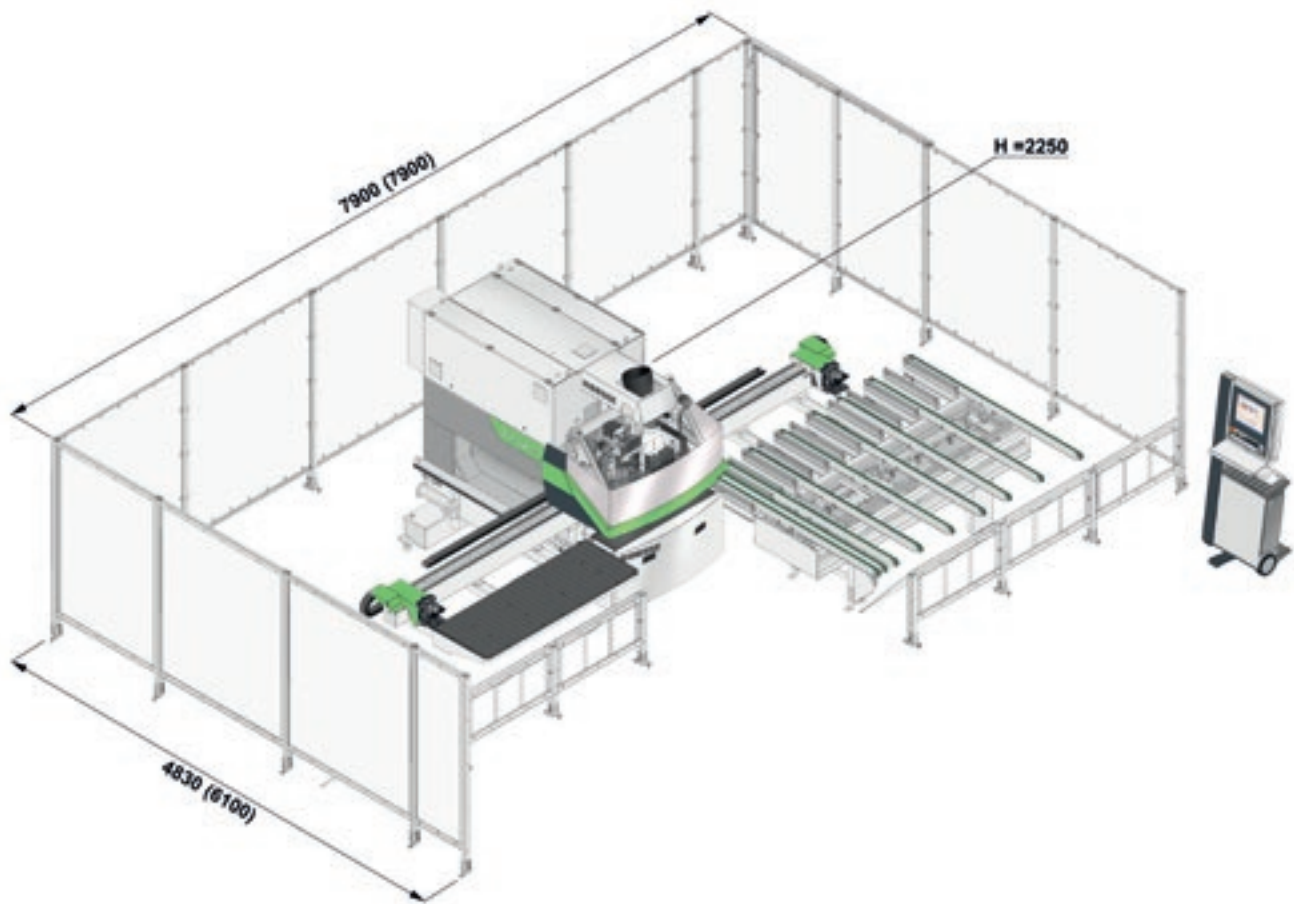

## SKIPPER 130

Length of machinable panels	90/3000 - 3.5/118.1 mm-inch
Width of machinable panels	70/1300 - 2.7/51.2 mm-inch
Thickness of machinable panels	8/90 - 0.3/3.5 mm-inch
Vertical boring spindles (above+below)	31
Boring spindle rotation speed (max)	6000 rpm
Horizontal boring spindles in X (above+below)	8+8
Horizontal boring spindles in Y (above+below)	2+2
Electrospindle kW 4.5 (above+below)	1+1
Electrospindle rotation speed (min-max)	1000/24000 rpm
Blade unit diam.160 mm (above+below)	1+1
Horizontal boring spindles in Y+ (below)	1-2
Glue-dowel insertion unit (above) in X	2

The technical specifications and drawings are non-binding. Some photos may show machines equipped with optional features. Biesse Spa reserves the right to carry out modifications without prior notice.

The measurement was carried out in compliance with UNI EN 848-3:2007, UNI EN ISO 3746: 2009 (sound power) and UNI EN ISO 11202: 2009 (sound pressure levels at workstation) during panel machining. The noise levels shown are emission levels and do not necessarily correspond to safe operation levels. Despite the fact that there is a relationship between emission and exposure levels, this may not be used in a reliable manner to establish whether further measures need to be taken. The factors determining the exposure level for the workforce include length of exposure, work environment characteristics, other sources of dust and noise, etc. i.e. the number of other adjoining machines and processes. At any rate, the above information will enable the operator to better evaluate dangers and risks.

Surface sound pressure level during machining in A (L<sub>pfA</sub>): 84 dB(A).

Sound power level during machining in A (L<sub>wA</sub>): 107 dB(A).

Measurement uncertainty K: 4 dB(A).



# Made **With** Biesse

## **Biesse Group technologies join forces with Lago's innovation and total quality management processes.**

In the crowded world of domestic design, Lago takes its place as an emerging brand, thanks to a collection of stimulating products and a corporate philosophy that embraces the interaction between business and art, coupled with on-going research into sustainable development. "We created a number of projects, or rather, concepts - states Daniele Lago - that have shaped Lago as we see it today: we saw design as a cultural vision that applies not only to individual products, but rather to the entire business chain".

"Flexibility is the key word here at Lago" says Carlo Bertacco, Manufacturing Manager. "We started to introduce the concept of processing only outstanding

orders, which enabled us to reduce our footprint and empty the site from the very beginning".

"The machinery that we purchased - states Bertacco - is great, it entailed a limited investment versus the capabilities it offers and is linked to a specific manufacturing approach. What I am talking about is a given manufacturing volume with Lago-standard quality levels and the possibility of customising as late as possible, at the customer's request: in short, the very basic principles of lean manufacturing".

*Source: IDM Industria del Mobile  
Lago, our customer since 1999, is one of most prestigious Italian furniture brands in the world.*



<http://www.lago.it>



# Biesse Group

In

1 industrial group, 4 divisions  
and 8 production sites.

How

€ 14 million p/a in R&D and 200 patents registered.

Where

34 branches and 300 agents/selected dealers.

With

customers in 120 countries (manufacturers of furniture,  
design items and door/window frames, producers of ele-  
ments for the building, nautical and aerospace industries).

We

3,200 employees throughout the world.

**Biesse Group** is a multinational leader in the  
technology for processing wood, glass, stone, plastic  
and metal.

Founded in Pesaro in 1969, by Giancarlo Selci, the  
company has been listed on the Stock Exchange  
(STAR segment) since June 2001.

 **BIESSEGROUP**

 **BIESSE**

 **INTERMAC**

 **DIAMUT**

**MECHATRONICS**

