

IRS

Standard and industrial Line

**SEGHE RADIALI
SCIES RADIALES
RADIALKREISSÄGEN
RADIAL ARM SAWS
SIERRAS RADIALES**



STROMAB
MACCHINE PER LA LAVORAZIONE DEL LEGNO

RS

Standard and industrial Line

STANDARD LINE RS 650 • RS 650S • RS 750 • RS 750S • RS 900 • RS 900S



RS 900

CE

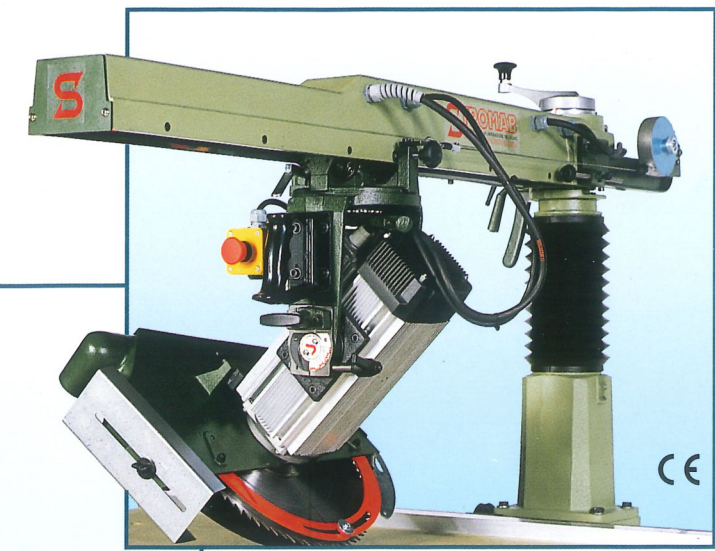

- Bracci in ghisa
- Guide intercambiabili
- Carrello a 8 cuscinetti
- Estrema rigidità e precisione di taglio
- Assoluta sicurezza

- Bras en fonte
- Glissières interchangeables
- Chariot à 8 rouleaux
- Rigidité extrême et précision parfaite
- Sécurité absolue

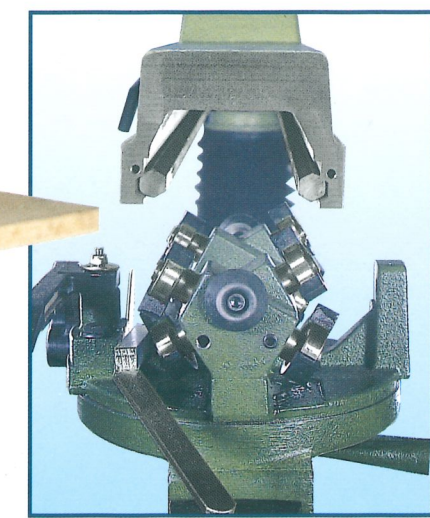

- Guß-Ärme
- Auswechselbare Führer
- Wagen mit 8 Kugeln
- Außerordentliche Schneidgenauigkeit
- Absolute Sicherheit

- Cast-iron arms
- Interchangeable guides
- Carriage with 8 rollers
- Extraordinary cutting accuracy
- Total operator safety



- Brazos en fundición
- Guías intercambiables
- Carro a 8 cojinetes
- Absoluta rigidez y calidad de corte
- Total seguridad

650S • RS 750 • RS 750S • RS 900 • RS 900S

RS

Standard and industrial Line

INDUSTRIAL LINE
RS 92 • RS 110 • RS 130

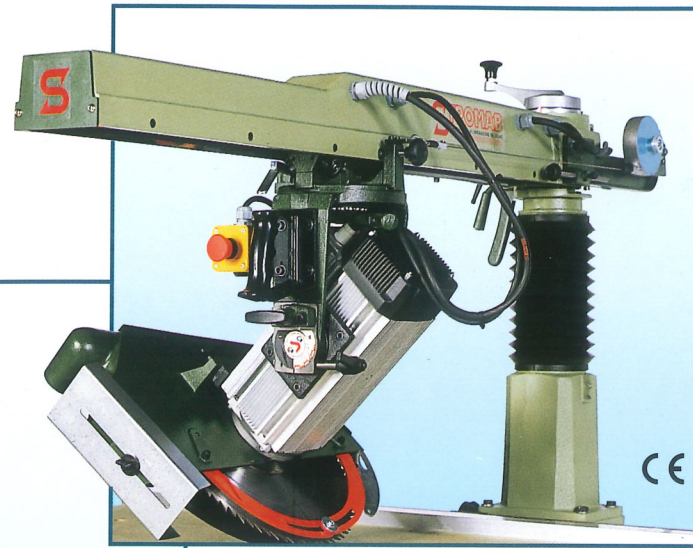

- Bracci in ghisa
- Guide intercambiabili in acciaio
- Carrello a 8 cuscinetti
- Estrema rigidità del braccio per la massima perfezione di taglio.
- Assoluta sicurezza dell'operatore

- Bras en fonte
- Glissières interchangeable en acier
- Chariot à 8 roulements
- Rigidité extrême du bras pour un decoupage parfait.
- Sécurité absolue de l'opérateur

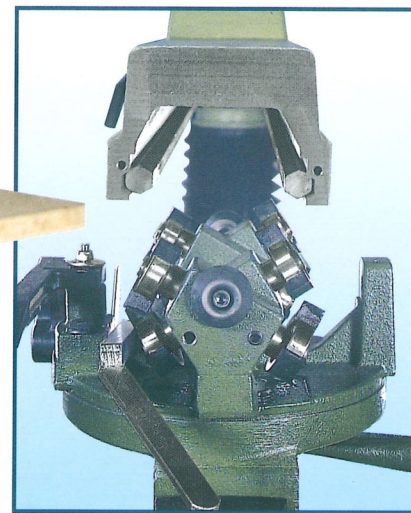

- Guß-Ärme
- Auswechselbare Laufschiene aus Stahl
- Wagen mit 8 Kugellagern
- Außerordentliche Steifigkeit des Armes für die maximale Schnittgenauigkeit
- Absolute Sicherheit des Bedieners

- Cast-iron arms
- Interchangeable steel slide-ways
- Carriage with 8 bearings
- Extraordinary arm rigidity for the utmost cutting accuracy
- Total operator safety



- Brazos en fundición
- Guías intercambiables en acero
- Carro a 8 cojinetes
- Absoluta rigidez del brazo por la máxima calidad de corte
- Total seguridad de trabajo



RS 92

VERSIONE NON CE
VERSION NON CE
VERSION OHNE
CE - AUSSTATTUNG
NON CE - VERSION
VERSION SIN EQUIPO CE

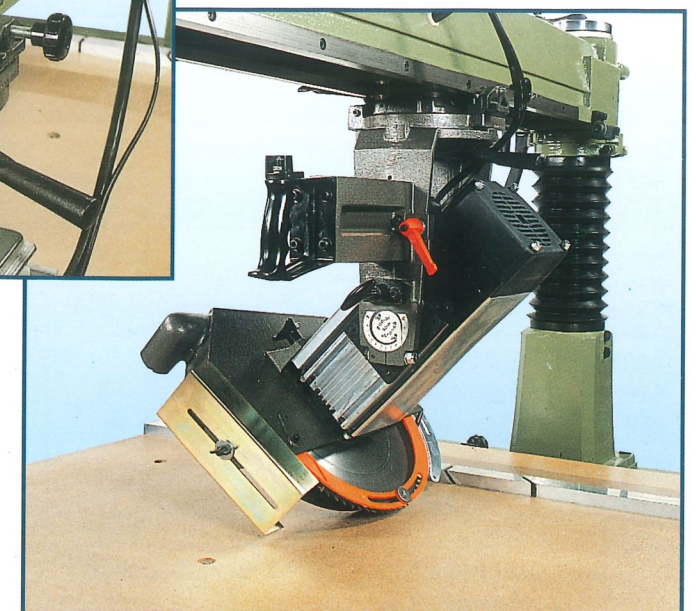

RS

Standard and industrial Line

SEGHE RADIALI
SCIES RADIALES
RADIALKREISSÄGEN
RADIAL ARM SAWS
SIERRAS RADIALES

DATI TECNICI • DONNEES TECHNIQUES TECHNISCHE DATEN • TECHNICAL DATA DATOS TECNICOS		STANDARD LINE						INDUSTRIAL LINE		
		RS 650	RS 650S	RS 750	RS 750S	RS 900	RS 900S	RS 92	RS 110	RS 130
Potenza motore trifase • Moteur triphase Drehstrommotor • Three phase motor Motor trifasico	Hp	3	4	3	4	4	5,5	6	6	6
	Kw	2,2	3	2,2	3	3	4	4,4	4,4	4,4
Potenza motore monofase • Moteur monophasé Lichtstrommotor • Single phase motor Motor monofasico	Hp	2	2	2	2	2				
	Kw	1,5	1,5	1,5	1,5	1,5	-	-	-	-
Diametro lama • Diametre de la lame Sägeblatt Ø • Blade diameter Hoja Ø	mm	300	350	300	350	350	400	400	400	400
Diametro foro lama • Alésage de la lame Sägeblattbohrung Ø • Motor arbor diameter Interior de la hoja Ø	mm	30	30	30	30	30	30	30	30	30
Velocità lama g./min. • TpM moteur Motordrehzahl UpM • Motor speed RPM Vueltas	n°	2800	2800	2800	2800	2800	2800	2800	2800	2800
Capacità a troncare • Capacité de tronçonnage Schnittlänge • Cross-cut capacity Capacidad de corte	mm	650	650	750	750	900	900	900	1080	1250
Cap. a troncare a 45° • Capacité de tronçonnage à 45° Schnittlänge bei 45° • Cross-cut capacity at 45° Capacidad de corte a 45°	mm	460	460	530	530	638	638	650	780	890
Profondità di taglio • Profondeur de coupe Schnitttiefe • Depth of cut Profundidad de corte	mm	75	100	75	100	100	120	120	120	120
Profondità di taglio con motore a 45° • Profondeur de coupe en biais à 45° • Schnitttiefe bei 45° Depth of cut at 45° • Profundidad de corte a 45°	mm	50	65	50	65	65	83	83	83	83
Angolazione braccio • Angle d'inclinaison du bras Schwenkblockierung des Arms • Miter locating stops Inclinacion brazo				0°	+45°	-45°		0°	+45°	-45°
Angolazione lama • Angle d'inclinaison de la lame Schwenkblockierung des Sägeblattes • Bevel locating stops Inclinacion hoja				0°	+45°	-45°		0°	+45°	-45°
Cuscinetti carrello • Roulements du chariot Kugellager des Laufwagens • Carriage bearings Cojinetes	n°	8	8	8	8	8	8	8	8	8
Peso netto • Poids net Netto Gewicht • Net weight Peso neto	Kg	200	210	230	240	250	260	400	430	460
Diametro bocca d'aspiraz. • Ø Buse d'aspiration Absaughaube Ø • Extractor hood Ø Boca d'aspiracion Ø	mm	120	120	120	120	120	120	120	120	120
Livello di rumorosità • Niveau du bruit Schalldruckpegel • Noise level Nivel de sonoridad	db(a)	84	84	84	84	84	84	84	84	84

DOTAZIONE STANDARD E OPZIONALI A RICHIESTA COME PRECISATO A LISTINO • EQUIPEMENT STANDARD ET OPTIONS SUR DEMANDE
COMME PRECISE SUR TARIF • STANDARD AUSRÜSTUNG UND SONDERZUBEHÖR AUF ANFRAGE LT. PREISLISTE • STANDARD EQUIPMENT
AND AVAILABLE OPTIONS ACCORDING TO PRICELIST • EQUIPO STANDARD Y ACCESORIOS SEGUN LISTA DE PRECIOS.



42017 NOVELLARA (RE) Italy - Via Provinciale Nord, 237 - Tel. 0522 653545 - Fax 0522 662952
E-mail: info@stromab.com - www.stromab.com