

UNTHA

shredding technology

product



RS30 / RS40

with patented 4-shaft shredding system

www.untha.com



Application

The tried and tested RS30 and RS40 shredders with patented 4-shaft shredding system are used by joiners' and carpenters' workshops, as well as saw-mills. The throughput of these machines ranges from 1 to 20m³/hr, depending on the material.

Suitable for shredding

- solid wood (long wooden parts, splinters)
- veneers
- cardboard / paper (mixed with wood)
- bark

The homogenous product produced through shredding is perfectly suitable for heat recovery, for the heating of buildings or drying chambers, and for the production of timber briquettes and bark mulch.

Take advantage of our good relationships with leading manufacturers of wood chip heating systems, suction systems, conveyor systems and briquette presses when designing your system.

The cutting system



All models of the RS30 and RS40 series are equipped with the patented UNTHA four-shaft cutting system with perforated screen (patent no. 319535).

Function and design

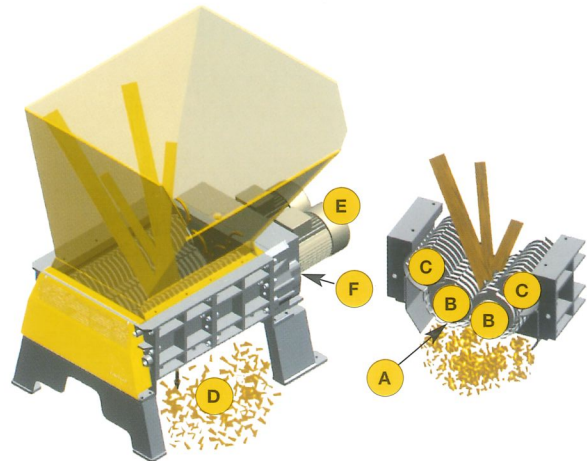

- The material to be shredded is automatically drawn into the cutting system and pre-shredded as well as re-shredded in one go.
- If material does not fall through the perforated screen after shredding (A), it is taken up by the teeth of the main cutting system (B) and moved back up (pre-shredding).
- The next shredding cycle (re-shredding) begins when the pre-shredded material is taken up by the secondary cutters (C).
- The machine is driven by two electric drive motors (E) and a 3-step spur gear (F).
- The final product is precisely defined, homogenous granules (D).

RS30 / RS40 4-shaft shredding system

For more information please visit www.untha.com

Persuasive technical solutions



Machine casing

- Solid cast frame
- High strength due to reinforcement ribs
- Modular design
- Strong floating bearing plate

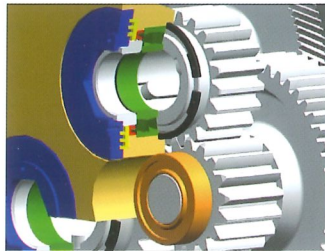

Shaft bearing

- Spherical roller bearings exclusively
- Additional sealing through labyrinth packing
- Lubrication for floating bearing
- High-quality bearings with long service life are used

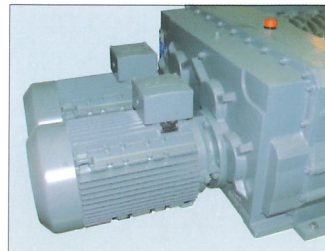

Driving unit

- The cutters are driven by two individually controlled electric motors
- Low-maintenance 3-step spur gear, running in oil bath, with high efficiency
- Smooth running due to helical gearing of the first step
- Ground wheels in the first step



Cutting system

- The cutting system consists of main cutters and secondary cutters
- The chopping disks are drop forged and case-hardened
- The chopping disk collar is forged in one piece with the chopping disk
- The cutters are mounted on four hexagonal shafts

Optional equipment

- Suction hoods (Suction possible on up to 4 sides)
- Customised filling funnels
- Customised chopping disks available
- Customised bases
- Pipe magnets
- Conveyor belt with magnet separation

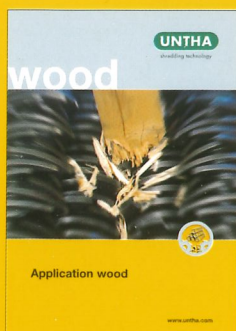

**Use the energy
that's in your waste wood!**

**For more information please request
our brochure on applications for wood!**

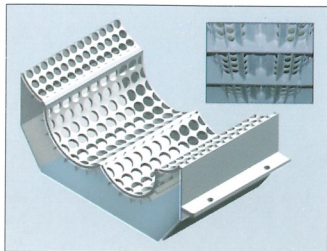

Perforated screen

- The perforated screen covers all four cutting shafts
- Extremely high throughput through 4 screen floors
- Equipped with chip breaker for reducing overly long material



Control unit with automatic recognition of foreign material

- Siemens LOGO control
- Control cabinet connected to the machine by a 4m cable
- Recognition of foreign material standard - The control unit stops the shredder automatically if an object that cannot be shredded (such as c-clamps, hammers, etc.) is pulled in by the rotor, thereby largely preventing damage.
- Further control features: Automatic reversing (in the event of motor overload); automatic stop (when machine idles)
- Integrated potential-free contact as standard equipment for discharge unit provided by client (suction, conveyor belt, screw conveyor, ...)





UNTHA shredding technology – Innovation in size reduction

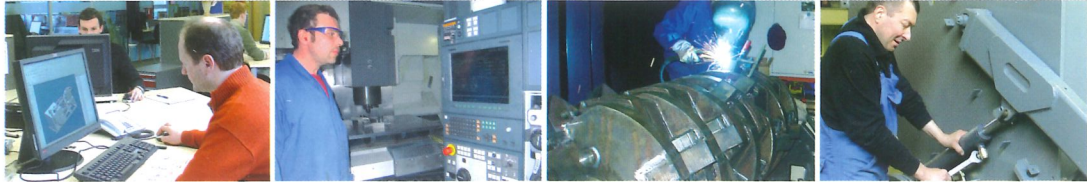

Tradition and Innovation

In 1970, Anton Unterwurzacher founded a company which has since become an international player: UNTHA shredding technology. In 1980, he developed the innovative four-shaft cutting system and specialised in the production of shredders.

UNTHA shredders stand out with their high quality, reliability and sturdiness. The machines are tailored to customer specifications. Delivery times can be kept short, since the majority of construction work is done by UNTHA itself. High quality and productivity are ensured by state-of-the-art production equipment.

UNTHA offers expertise in consulting, production and sales world-wide!

The team of UNTHA shredding technology, with its 100 highly qualified and motivated staff, provides comprehensive consulting and support. The international sales network, with partners in more than 60 countries, ensures swift processing of your inquiries as well as immediate service on site.

We keep our promises!

UNTHA shredding technology – your reliable expert partner in shredding technology – employs the most advanced technology to find the optimum solutions for your requirements. The highest technical standards and our comprehensive service and support guarantee trouble-free operation of equipment and keep stand-still times of your plant to an absolute minimum.

30 years of expertise
More than 8,000 shredders
in daily operation!

Technical data RS30 / RS40 4-shaft shredding system

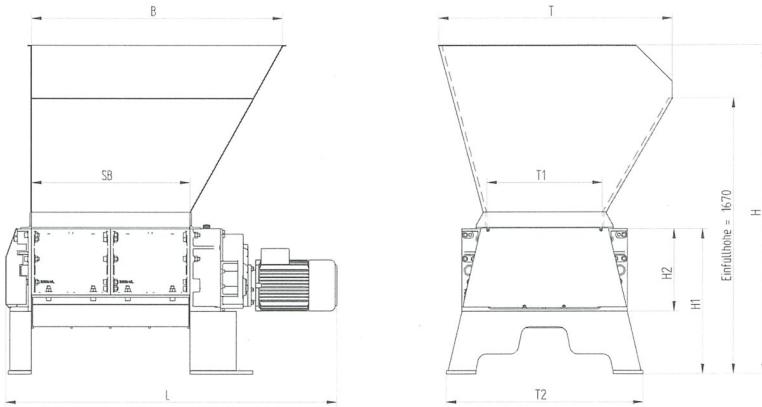

All dimensions in mm | SB = width of cutting system

Machine type / Dimensions	SB	L	H	H1	H2	B	T	T1	T2
RS30 / 2 x 5,5 kW	450	1,250	1,900	820	450	1,000	1,280	560	1,090
RS30 / 2 x 7,5 kW	450	1,300	1,900	820	450	1,000	1,280	560	1,090
RS30 / 2 x 11 kW	450	1,340	1,900	820	450	1,000	1,280	560	1,090
RS40 / 22 kW	450	1,360	1,970	820	450	1,000	1,370	700	1,190
RS40 / 22 kW	750	1,660	1,970	820	450	1,300	1,370	700	1,190
RS40 / 30 – 37 kW	480	1,530	1,990	880	500	1,045	1,415	700	1,190
RS40 / 30 – 37 kW	750	1,800	1,990	880	500	1,315	1,415	700	1,190
RS40 / 30 – 37 kW	960	2,010	1,990	880	500	1,525	1,415	700	1,190

Model series		RS30	RS40 / 22 kW	RS40 / 30-37 kW
Driving power	[kW]	2x5,5 / 2x7,5 / 2x11	2x11	2x15 / 2 x 18,5
Charging hole	[mm]	450 x 560	450/750 x 700	480/750/960 x 700
No. of blade shafts		4	4	4
Speed main shaft	[rpm]	approx. 23	approx. 20	approx. 23
Speed secondary shaft	[rpm]	approx. 34	approx. 28	approx. 32
Perforated screen Ø	[mm]	15 – 40	15 – 40	15 – 40
Weight	[kg]	approx. 1,100	app. 1,400/1,700	app. 1,700/2,100/2,400
Noise level, operation	[dB]	approx. . 80*	approx. 80*	ca. 80*
Throughput*				
- Perforated screen Ø 15 – 25 mm	[m ³ /hr]	1 – 3	1 – 4	2 – 5
- Perforated screen Ø 30 – 40 mm	[m ³ /hr]	3 – 5	3 – 6	4 – 8

*) depending on: quality of material and diameter of perforated screen

Distributors

UNTHA

shredding technology

Anton Unterwurzacher Maschinenbau GmbH

Moldanstraße 141, A-5431 Kuchl / Salzburg, Austria, Tel +43 6244 7016 0, Fax +43 6244 7016 1

untha@untha.com, www.untha.com