

ANDERSON

CNC PRODUCT RANGE

R&D | ENGINEERING | MANUFACTURING | SALES | SERVICE

GROUP

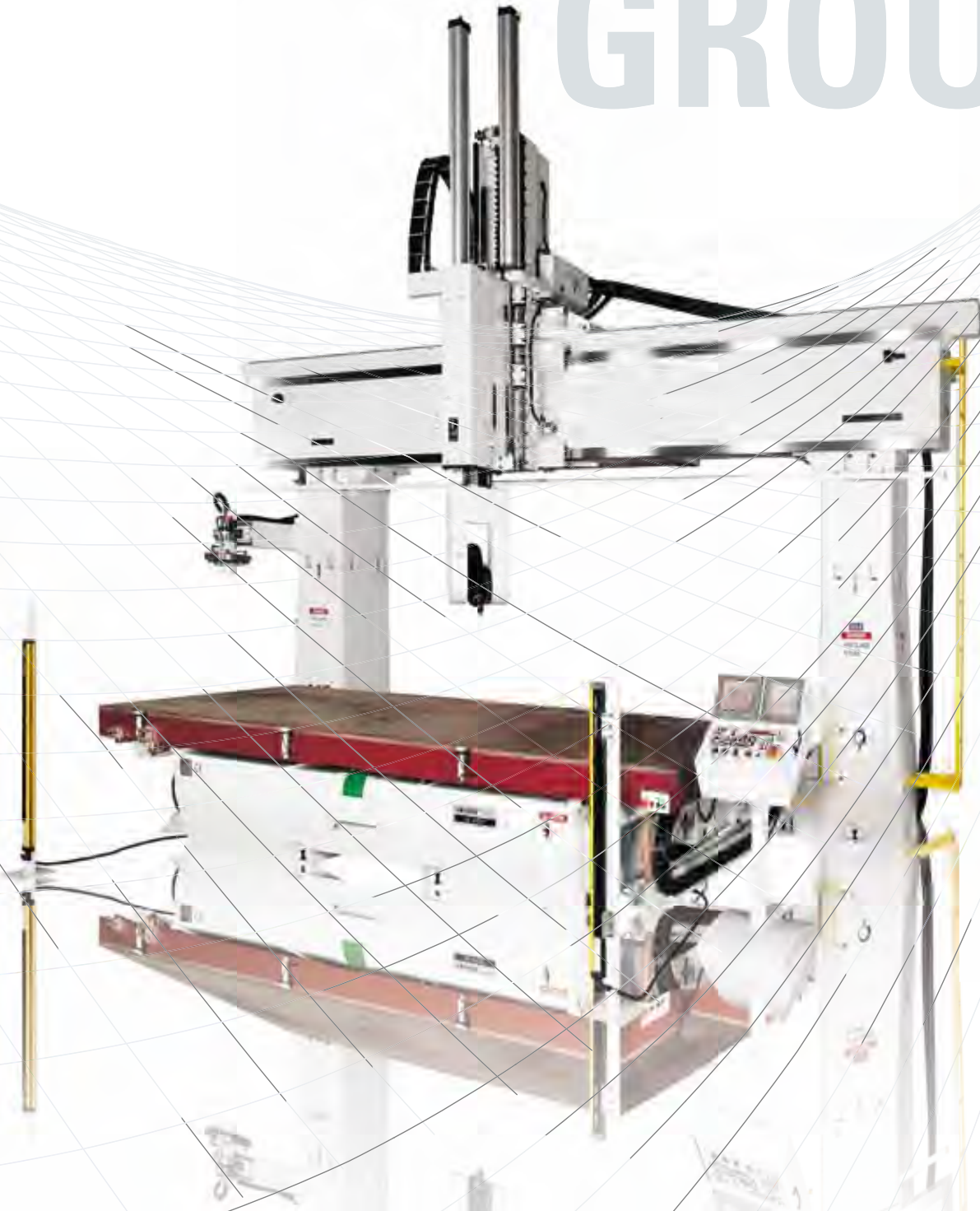

ABOUT US

ANDERSON AMERICA CORPORATION



The Anderson facility in Pineville, North Carolina.

INNOVATIONS IN DEVELOPMENT AND ENGINEERING

Since the mid 80's Anderson Industrial Corporation has been instrumental in the design and manufacturing of quality CNC machining centers to serve the leaders of industries around the world.

Designed around many applications to suit a variety of clients with varying products, Anderson CNC processing centers reflect 40 years of engineering and technological development. At the core of Anderson's CNC offering is our PTP, Selexx, Stratos, Exxact and Andimaxx series. These centers form Anderson's standard production series and when joined by our CNC series of fully customized machines, offers our client a solution that is both well engineered and to the most exacting of standards.

For customers in need of a 5-axis solution, Anderson offers many designs including the Axxiom and Maxxis, as well as fully customized Open Gantry and Bridge Gantry models.



ABOUT US

ANDERSON AMERICA CORPORATION



ANDERSON AMERICA CORP.

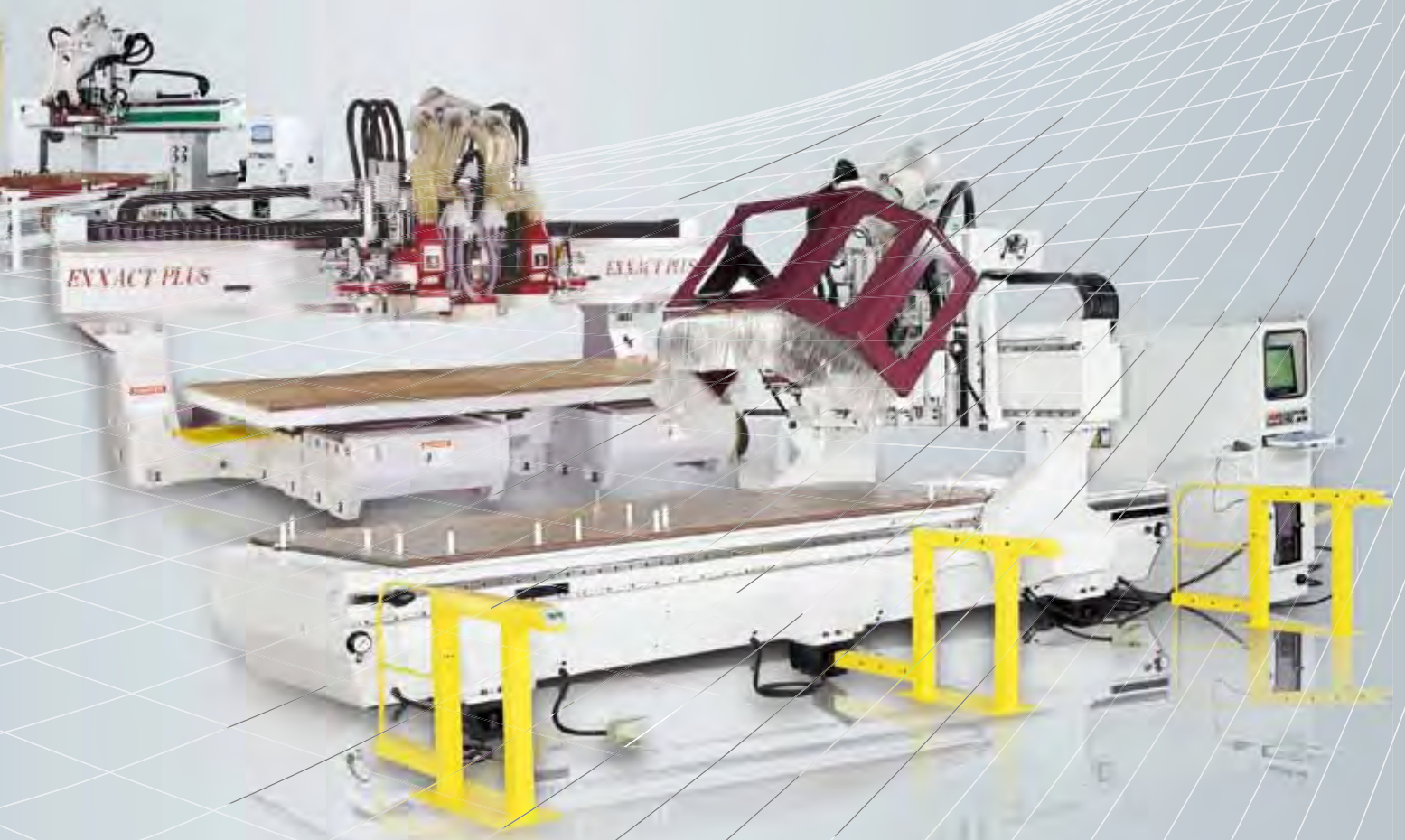

THE STRATOS SERIES

TRAVELING GANTRY



The STRATOS Series Traveling Gantry 3-axis machining centers set a new level of CNC accuracy and machining performance. The combination of a highly rigid base, steel weldments and castings and high accuracy Servo System make the STRATOS machining centers an ideal choice for machining wood, MDF, plywood, plastic, honeycomb aluminum and solid surface materials.

The Anderson Traveling Gantry design provides easy machine access. The modular concept comes in a variety of machine formats and sizes. The STRATOS machining centers set a new standard in cost effective, high speed CNC machining. CNC Controls include Ethernet options to provide remote technical support; optional C-axis available. Work piece holding flexibility is provided by optional clamping, grid or manifold vacuum systems. The STRATOS CNC Machining Center utilizes an industry standard G-code for control functions that allows easy interfacing with all major CAD/CAM software and industry standard solid modeling software packages. Additional options include work piece dimension probing, both single and dual zone capabilities and custom configurations upon request.

Basic configuration	Stratos Pro-E	Stratos Pro	Stratos Pro XL	Stratos Pro PXL
No. of vacuum zones	2	2	2	2
Table size X	3700 mm (146 in)	3700 mm (146 in)	3700 mm (146 in)	3700 mm (146 in)
Table size Y	1600 mm (63 in)	1600 (63 in)	2100 (83 in)	1600 (63 in)
Stroke of X-axis	3900 mm (154 in)	3900 mm (154 in)	3900 mm (154 in)	3900 mm (154 in)
Stroke of Y-axis	2180 mm (86 in)	2180 mm (86 in)	2180 mm (86 in)	2180 mm (86 in)
Stroke of Z-axis	350 mm (14 in)	350 mm (14 in)	350 mm (14 in)	350 mm (14 in)
Rapid travel Speed in X	80 M/min	80 M/min	80 M/min	80 M/min
Rapid travel Speed in Y	60 M/min	60 M/min	60 M/min	60 M/min
Rapid travel Speed in Z	30 M/min	30 M/min	30 M/min	30 M/min
Spindle Data				
Power	15 HP	15 HP	15 HP	15 HP
Max. Speed (rpm)	24000	24000	24000	24000
Clamping system	SK 30/HSK 63	SK 30/HSK 63	SK 30/HSK 63	SK 30/HSK 63
Tool changer	8	10	10	10
Boring block				
Vacuum pump controller	10/25/40 HP ANDI-FANUC	10/25/40 HP ANDI-FANUC	10/25/40 HP ANDI-FANUC	10/25/40 HP ANDI-FANUC
Dimensions: A	7000 mm (276 in)	7000 mm (276 in)	7000 mm (276 in)	7000 mm (276 in)
B	3750 mm (148 in)	3750 mm (148 in)	4250 mm (168 in)	3750 mm (148 in)
C	2950 mm (116 in)	2950 mm (116 in)	2950 mm (116 in)	2950 mm (116 in)
Weight	6000 kg	6100 kg	7000kg	7000 kg
OPTIONAL				
Reverse Air Flow	optional	optional	optional	optional
Bar-Code Reader	optional	optional	optional	optional
C-axis	optional	optional	optional	optional
Pusher	optional	optional	optional	optional



Automatic pop-up pins for assisting in part and sheet location are standard on all STRATOS Machines.

The STRATOS Series is available with a wide variety of vacuum pump options including 10 HP, 25 HP, 40 HP and 50 HP Models.



The STRATOS Series is available with multiple 32 mm system line boring units with vertical, horizontal and grooving saw options.

Common spindle configuration on the STRATOS Series: Line boring unit, HSK spindle, traveling tool carousel.

THE ANDIMAXX SERIES

MOVING TABLE FRONT TO BACK



The ANDIMAXX Series Moving Table 3-axis machining centers set a new level of CNC accuracy and machining performance. The combination of a highly rigid base, steel weldments and castings and high accuracy Servo System make the ANDIMAXX an ideal choice for machining wood, MDF, plywood plastic, aluminum and composite materials.

The Anderson fixed bridge and moving table design provides easy machine access. The webbed steel substructure remains smooth and rigid while cutting in X, Y and Z-axis. The ANDIMAXX CNC machining centers set a new standard in high speed CNC machining and as it is designed to handle heavy

duty CNC machining in thin and thicker flat and aluminum plate.

The ANDIMAXX CNC machining center is designed to handle heavy duty CNC machining in thin and thicker flat and autoclaved composites.

CNC Controls include Ethernet options to provide remote technical support; optional C-Axis is available. Work piece holding flexibility is provided by optional clamping, grid or manifold vacuum systems.

The ANDIMAXX CNC Machining Center utilizes an industry standard G-code for control functions that allows easy interfacing with all major CAD/CAM software and industry standard solid modeling software packages.

Basic configuration	ANDIMAXX
No. of tables	1
No. of vacuum zones per table	2
Table size X	3700 mm (146 in)
Table size Y	1600 mm (63 in)
Stroke of X-axis	2000 mm (79 in)
Stroke of Y-axis	4100 mm (162 in)
Stroke of Z-axis	250 mm (10 in)
Rapid travel Speed in X	60 M/min
Rapid travel Speed in Y	60 M/min
Rapid travel Speed in Z	12 M/min
Spindle Data	
Power	11 Kw
Max. Speed (rpm)	24000
Clamping system	HSK-63F
Tool changer	10
Boring block	ANDI Type
Vacuum pump	500 m ³ /HR
Controller	ANDI-FANUC
Dimensions: Floor Area	8550 x 3600 mm (337 x 142 in)
Height	3920 mm (155 in)
Weight	15000 kg

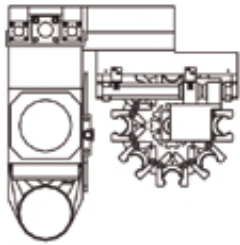

TC

Standard spindle configuration is a 15 HP Air cooled dynamic (travels with spindle) router spindle 0-24,000 rpm. 10, 12 or 16-position automatic tool changers are options. Robotic Arm Tool Changer and Water Cooled spindle versions are available. Single and Twin spindles option available.

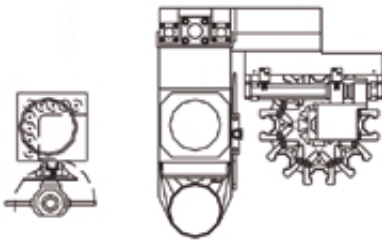
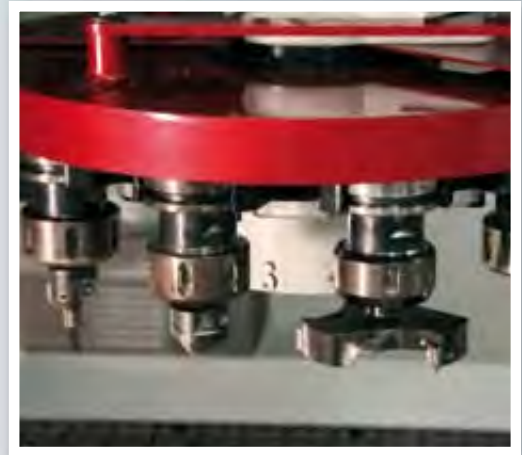

TC+D

Standard boring unit is a 5 x 5 vertical spindle unit with horizontal boring unit with slotting saw option.



TC2

Open Architecture ANDI-Fanuc control with PC front-end processes industry standard code via a standalone Windows PC or Network PC enabling users to work with virtually any CAD/CAM or 3rd party software supplier.



The optional roller holddown system is designed to apply vertical (downward) pressure to aid the vacuum system in securing parts in a nested-based application that cannot be held properly via vacuum alone or for multiple sheet stacking.

THE EXXACT SERIES

MOVING TABLE LEFT TO RIGHT



The EXXACT Series Moving Table 3-axis machining centers set a new level of CNC accuracy and machining performance. The combination of a highly rigid base, steel weldments and castings and high accuracy Servo System make the EXXACT an ideal choice for machining wood, MDF, plywood, plastic, aluminum and composite materials.

The Anderson fixed bridge and moving table design provides easy machine access. The webbed steel substructure remains smooth and rigid while cutting in X, Y and Z-axis. The EXXACT CNC machining centers set a new standard in high speed CNC machining as it is designed to handle heavy duty CNC machining in various thicknesses flat and aluminum plate. CNC Controls include Ethernet options to provide remote technical support; optional C-axis is available. Work piece holding flexibility is provided by optional clamping, grid or manifold vacuum systems. The EXXACT CNC Machining Center utilizes an industry standard G-code for control functions that allows easy interfacing with all major CAD/CAM software and industry standard solid modeling software packages.

Basic configuration	EXXACT plus	EXXACT plus duo
No. of tables	1	2
No. of vacuum zones per table	1	1
Table size X	3700 mm (146 in)	2x 3700 mm (2x 146 in)
Table size Y	1600 mm (63 in)	2x 1600 mm (2x 63 in)
Stroke of X-axis	4400 mm (174 in)	4400 mm (174 in)
Stroke of Y-axis	1775 mm (70 in)	1775 mm (70 in)
Stroke of Z-axis	350 mm (14 in)	350 mm (14 in)
Rapid travel Speed in X	80 M/min	80 M/min
Rapid travel Speed in Y	80 M/min	80 M/min
Rapid travel Speed in Z	20 M/min	20 M/min
Spindle Data		
Power	15 HP	15 HP
Max. Speed (rpm)	24000	24000
Clamping system	HSK-63F	HSK-63F
Tool changer	10	10
Boring block	ANDI Type	ANDI Type
Vacuum pump	25 HP	25 HP
Controller	ANDI-FANUC	ANDI-FANUC
Dimensions: Floor Area	6000 x 3375 mm (236 x 133 in)	6000 x 3375 mm (236 x 133 in)
Height	2800 mm (110 in)	2800 mm (110 in)
Weight	7000 kg	7000 kg

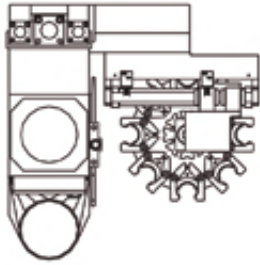

TC

One ANDI HSK-63F spindle with 10 position tool carousel. Standard spindle configuration is a 15 HP Air cooled dynamic (travels with spindle) router spindle 0-24000 rpm. 10, 12 or 16-position automatic tool changers are options. Robotic Arm Tool Changer and Water Cooled spindle versions are available.

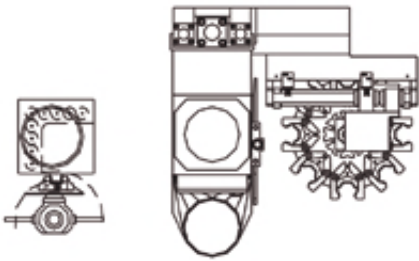

TC+D

One ANDI HSK-63F spindle with 10-position tool carousel and one 32 mm 5x5 Vertical Drill Block.

Optional horizontal drills and grooving saw.

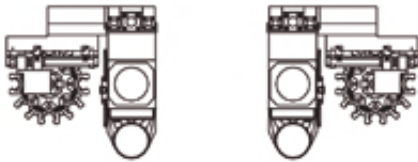

TC2

Two ANDI HSK-63F spindles each with 10-position tool carousel.



TC2+D

Two ANDI HSK-63F spindles with 10-position tool carousel.

One 32 mm 5x5 Vertical Drill Block.



TC2+D2

Two ANDI HSK-63F spindles with 10-position tool carousel.

Two 32 mm 5x5 Vertical Drill Block.



A 10-position traveling tool carousel is standard on all EXXACT PLUS models, however various options for expanding tool storage are available.



Heavy duty, cast iron machine construction for rigid and accurate machining performance.



Various line boring units, spindle and tool carousel combinations allow customers to configure the machine for their specific application and budget.

THE EXXCEL SERIES

MOVING TABLE | HIGH PRECISION LINEAR DRIVE

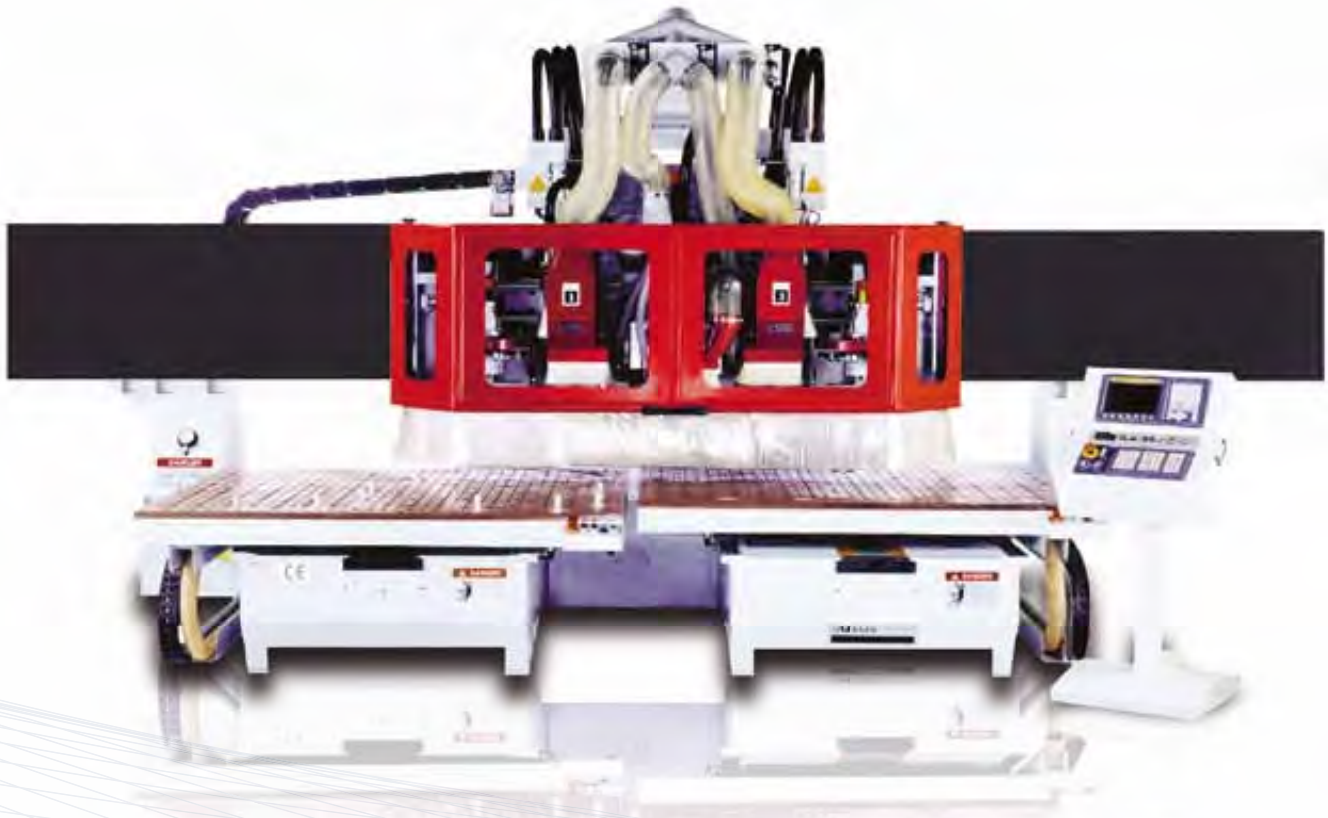

The EXXCEL Series Moving Table 3-axis machining centers set a new level of very High Precision CNC accuracy and machining performance. The combination of a highly rigid base, steel weldments and castings and high accuracy Linear Motor Servo System make the EXXCEL an ideal choice for machining wood, MDF, plywood, plastic, aluminum and composite materials.

The Anderson fixed bridge, moving table design and all magnetic drive motors make the EXXCEL one of world's fastest and accurate CNC machining centers. The webbed steel substructure and Linear motor drives provide the EXXCEL with a very rapid acceleration profile as well as superior accuracy and extremely low vibration. The EXXCEL CNC machining centers

set a new standard in very high precision, high speed CNC machining. The EXXCEL CNC machining center is designed to handle high speed CNC machining, trimming, slotting and drilling on all types of hardwoods and more. CNC Controls include Ethernet options to provide remote technical support; optional C-axis is available.

Work piece holding flexibility is provided by optional clamping, grid or manifold vacuum systems. The EXXCEL CNC Machining Center utilizes an industry standard G-code for control functions that allows easy interfacing with all major CAD/CAM software and industry standard solid modeling software packages. Additional options include work piece dimension probing, both single and dual zone capabilities and custom configurations upon request.

Basic configuration	EXXCEL	EXXCEL duo
No. of tables	1	2
No. of vacuum zones per table	1	1
Table size X	3700 mm (146 in)	2x 1840 (73 in)
Table size Y	1600 mm (63 in)	1600 mm (63 in)
Stroke of X-axis	4450 mm (175 in)	4450 mm (175 in)
Stroke of Y-axis	1800 mm (71 in)	1800 mm (71 in)
Stroke of Z-axis	300 mm (12 in)	300 mm (12 in)
Rapid travel Speed in X	100 M/min	100 M/min
Rapid travel Speed in Y	100 M/min	100 M/min
Rapid travel Speed in Z	30 M/min	30 M/min
Spindle Data		
Power	15 HP	15 HP
Max. Speed (rpm)	1000-22000	1000-22000
Clamping system	HSK-63F	HSK-63F
Tool changer	max 32	max 32
Boring block	Anderson Type	Anderson Type
Vacuum pump	25 HP	25 HP
Controller	ANDI-FANUC	ANDI-FANUC
Dimensions: Floor Area	6500 x 4200 mm (256 x 165 in)	6500 x 4200 mm (256 x 165 in)
Height	3300 mm (130 in)	3300 mm (130 in)
Weight	11000 kg	11000 kg



TC / TC2

One or two ANDI HSK 63 F Spindles with 10-position tool carousel available.



TC+D / TC2 +D

One or two ANDI HSK 63 F spindle with 10-position tool carousel. One 32mm Vertical Drill Blocks with horizontal drills and slotting saw.

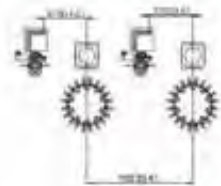

TC2 / D2

One or two ANDI HSK 63 F spindle with 10-position tool carousel. Two 32mm Vertical Drill Blocks with horizontal drills and slotting saws.

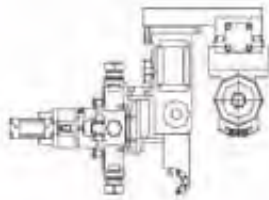

RAN

One ANDI HSK 63 F Spindles with 12, 16 or 32-position tool carousel available.

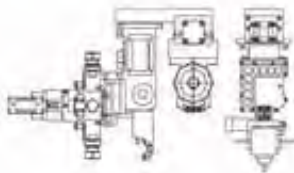

RAN+D

One ANDI HSK 63 F spindle with 12, 16 or 32-position tool carousel.

One 32mm 5 x 5 Vertical Drill Block with horizontal drills and slotting saw.



MH

Two ANDI HSK63F spindle with 12, 16 or 32-position tool change RanRob system

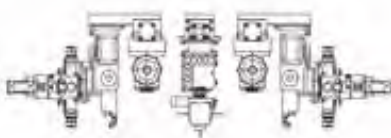

MH+D

Two ANDI HSK63F spindle with 12, 16 or 32-position tool change RanRob system.

Two ANDI HSK 63 F spindle with 12, 16 or 32-position tool carousel. One 32mm 5 x 5 Vertical Drill Block with horizontal drill and slotting saw.



MH+D2

Two ANDI HSK 63 F spindle with 12, 16 or 32-position tool carousel. Two 32mm 5 x 5 Vertical Drill Blocks with horizontal drill and slotting saw.



A 10-position traveling tool carousel is standard on all EXXCEL models with various options for expanded tool storage available.



The EXXCEL Series is available with multiple 32 mm line boring units with vertical, horizontal and grooving saw options.



Various line boring unit, spindle and tool carousel combinations allow customers to configure the machine for their specific application and budget.

THE PTP SERIES

POINT TO POINT



The Anderson PTP Series defines excellence in traditional manufacturing processes by offering a wide selection of machine configurations to meet our client's needs.

By making use of many tested and proven features found in other products engineered by Anderson, such as the use of high grade components and heavy duty, cast iron base and gantry construction, the Anderson PTP Series offers clients a truly world class Point to Point manufacturing system. Together with a well-engineered machine, Anderson has completed its Point to Point machining center with an easy to use and fully integrated software package that allows for streamlined workflow and seamless parts designing with motion control being handled by a Syntec CNC Controller.

With Anderson, your traditional method of manufacturing can be revolutionized to boost your production and put you ahead of the competition.

Basic configuration	PTP 2813	PTP 2814	PTP 3213	PTP 3214
Vacuum Area (inch)	123,2 x 56 x 6	123,2 x 62 x 6	138,8 x 56 x 10	138,8 x 62 x 10
Table size X x Y x Z (inch)	112,2 x 51,2 x 4	112,2 x 57 x 4	126 x 51,2 x 8	126 x 57 x 8
Speed X-axis	80-60-20 m/min	80-60-20 m/min	80-60-30 m/min	80-60-30 m/min
Driven system X-axis and Y-axis	rack & pinion	rack & pinion	rack & pinion	rack & pinion
Driven system Z-axis	ballscrew	ballscrew	ballscrew	ballscrew
Table type	tubeless	tubeless	tubeless	tubeless
Rails	6	6	6	6
Pods	18	18	18	18
Front stops / intermediate stops	6 / 6	6 / 6	6 / 6	6 / 6
Side stops	1R+1L	1R+1L	1R+1L	1R+1L
Panel lifting blades	4	4	4	4
Vacuum pump	90 m ³ /h	90 m ³ /h	90 m ³ /h	90 m ³ /h
Aggregate Head	11	11	23	23
Independent vertical spindles on X / Y	5 / 5	5 / 5	10 / 7	10 / 7
Independent horizontal spindles on X / Y	1+1 / 1+1	1+1 / 1+1	2+2 / 1+1	2+2 / 1+1
Drilling step	32 mm (1,3 in)	32 mm (1,3 in)	32 mm (1,3 in)	32 mm (1,3 in)
Motor	2,25 Kw	2,25 Kw	2,25 Kw	2,25 Kw
Rotation	4800 rpm	4800 rpm	4800 rpm	4800 rpm
Saw Blade 90° rotation	standard	standard	standard	standard
Motor	1,5 Kw	1,5 Kw	2,25 Kw	2,25 Kw
Blade diameter	120 mm (4,7 in)	120 mm (4,7 in)	125 mm (4,9 in)	125 mm (4,9 in)
Main head	3 axis	3 axis	3 axis	3 axis
Spindle 8Kw 1000-18000 rpm Cone ISO 30	standard	standard		
Spindle 12 Kw 1000-24000 rpm Cone HSK-63F	optional	optional	standard	standard
Automatic stationary tool change	8 positions	8 positions	8 positions	8 positions
Tool diameter max.	110 mm (4,3 in)	110 mm (4,3 in)	110 mm (4,3 in)	110 mm (4,3 in)
C-Axis rotation			optional	optional
Light barriers	standard	standard	standard	standard
Safety hood for Spindle	standard	standard	standard	standard
Handwheel	standard	standard	standard	standard
NC Controller	Syntec	Syntec	Syntec	Syntec
Weight	2800 Kg	3000 Kg	3300 Kg	3500 Kg



Both residential and commercial applications



The moveable beams and suction cups allow you to process different kinds of work pieces by utilizing different manufacturing procedures.



The standard 32 mm boring unit is a 10x7 vertical spindle unit with optional horizontal drills.



A laser positioning system is used for automatically positioning beams and suction cups. Panel lifting blades make easy work of positioning and moving heavy work pieces.



Various drill head, spindle and tool changer combinations allow clients to design the machine specifically for their application and budget.

MOVING TABLE 5-AXIS SERIES

THE AXIOM AND THE MAXXIS



Basic configuration	Omnitech/rack Axiom (single Table)	Omnitech/rack Axiom (twin table)	Anderson Maxxis (twin table)	Anderson Maxxis (twin table)
Application	Plastic trimming/Composites	Plastic trimming/Composite3s	Aluminum/Composites	Aluminum/Composites
Table configuration	Flat	Flat	Flat	Flat
Table Style	HPL Grid	HPL Grid	HPL Grid or Alum 50mm with T Slots	HPL Grid or Alum 50mm with T Slots
Zones	1 zone	1 zone x 2	1 zone	1 zone x 2
Table Size in mm (metric)	1600 x 1800 IP 1600 x 3100 IP	1600 x 1800 IP 1600 x 3100 IP	1600 x 1800 IP 1600 x 3100 IP	width 1600 mm to 3100 mm length 1800 mm to 7000 mm
Table Height	600 mm (23,6 in)	800 mm (31,5 in)	800 mm (31,5 in)	800 mm (31,5 in)
Standard Z (stroke) #1	800 mm (31,5 in)	800 mm (31,5 in)	800 - 1200 mm (31,5 - 47,2 in)	800 - 1200 mm (31,5 - 47,2 in)
Standard Z (stroke) #2	1200 mm (47,2 in)	1200 mm (47,2 in)	1200 mm (47,2 in)	1200 mm (47,2 in)
B and C-axis	B : ± 120° C : ± 270°	B : ± 120° C : ± 200°	B : ± 120° C : ± 270°	B : ± 100° C : ± 200°
Control	Syntec 5-Axis	Syntec 5-Axis	FANUC 31i or SIEMENS 840D	FANUC 31i or SIEMENS 840D
Router Spindle	HSK 32E, 11 HP (40000 rpm)	HSK 32E, 11 HP (40000 rpm)	10 HP, 15 HP(HSK 63F, 22000 rpm) 20HP (HSK 63E, 18000 rpm)	10 HP, 15 HP(HSK 63F, 22000 rpm) 20HP (HSK 63E, 18000 rpm)
Type ATC	8	8	ATC : 10, 16, 20 Ranrob : 12, 16, 20, 32	ATC : 10, 16, 20 Ranrob : 12, 16, 20, 32
Barriers	n/a	n/a	n/a	n/a
Included	Vac. Prep Kit	Vac. Prep Kit	Vac. Prep Kit	Vac. Prep Kit
Pump Size	BECKER 250 cbm 10,25,40,50 HP (options)	BECKER 250 cbm 10,25,40,50 HP (options)	BECKER 500 cbm 10,25,40,50 HP (options)	BECKER 500 cbm 10,25,40,50 HP (options)
Safety fence	optional	optional	optional	optional
X-Drive System	Rack	Rack	Ball Screw	Ball Screw
Y-Drive System	Rack	Rack	Ball Screw	Ball Screw
V-Drive System	n/a	Rack	n/a	Ball Screw
Z-Drive System	Ball Screw	Ball Screw	Ball Screw	Ball Screw
Rapids/cutting X,Y,Z	X;Y;Z=80/80/24 m/m	X;Y;Z=60/60/20 m/m	X;Y;Z=80/80/24 m/m	X;Y;Z=80/80/24 m/m
Rapids/cutting C, B	B&C=90°/sec 24 m/m	B&C=60°/sec 24 m/m	B&C=90°/sec 24 m/m	B&C=90°/sec 24 m/m
Remote Internet Diagnostics	yes	yes	yes	yes
Tool Holders	yes	yes	n/a	n/a
Touch-Off Device	optional	optional	optional	optional

The AXXIOM and MAXXIS Series Moving Table 5-axis machining centers set a new level of 5-axis accuracy and machining performance. The combination of a highly rigid base, precision gearbox and high accuracy Servo System make the AXXIOM and MAXXIS an ideal choice for machining plastics, aluminum and composite materials.

The Anderson fixed bridge and moving table design provides easy machine access in a compact easy-to-access design. The webbed steel substructure remains smooth and rigid while all 5-axis are in full 5-axis machining mode. The AXXIOM

and MAXXIS 5-axis machining centers set a new standard in high speed 5-axis machining.

AXXIOM

The AXXIOM 5-axis machining center is designed to handle high speed 5-axis machining trimming, slotting and drilling in thin rigid materials, such as thermoformed plastics and autoclaved composites.

MAXXIS

The MAXXIS 5-axis machining center is designed to handle heavy duty 5-axis machining in thicker thermoformed and resin plastics, aluminum and thicker autoclaved composites.

- Advanced 5-axis CNC features are available on both models
- CNC Controls include Ethernet options to provide remote technical support
- Work piece holding flexibility is provided by optional clamping, grid, or manifold vacuum systems

The AXXIOM and MAXXIS both utilize an industry standard G-code for control functions that allows easy interfacing with all major CAD/CAM software and industry standard solid modeling software packages. Additional options include work piece dimension probing, both single and dual zone capabilities and custom configurations upon request.



Plastics and composites trimming



CNC precision machining of composites and aluminum



Several Spindle options are available to meet the application from 8.1 HP 40,000 rpm to 25 HP 22,000 rpm.



Controller options from FANUC, Syntec and Siemens allow for a wide range of motion control options.

TRAVELING GANTRY 5 AXIS SERIES

MOVE POD & RAIL | MOVE FLAT TABLE



Basic configuration	Anderson/rack Stratos 5-axis	Anderson/rack Stratos 5-axis
Application	Aluminum Extrusion, Composites, and Wood	Aluminum Extrusion, Composites, and Wood
Table configuration	Flat Table	Pod & Rail
Table Style	Grid	Grid
Zones	2 zone	2 zone
Table Size in mm (inch)	width : 1300 length : 3700 ~ 7200 (every 500 mm)	width : 1300 length : 3700 ~ 7200 (every 500 mm)
Table Height	660 mm (26 in)	660 mm (26 in)
Standard Z (stroke) #1	600 mm (23,6 in)	600 mm (23,6 in)
Standard Z (stroke) #2	800 mm (31,5 in)	800 mm (31,5 in)
B and C-axis	B : $\pm 100^\circ$ C : $\pm 200^\circ$	B : $\pm 100^\circ$ C : $\pm 200^\circ$
Control	Syntec or SIEMENS 840D FANUC	Syntec or SIEMENS 840D (from AIC) FANUC (from local)
Router Spindle	15 HP or 20 HP (HSK 63F, 22000 rpm)	15 HP or 20 HP (HSK 63F, 22000 rpm)
Type ATC	ATC : 20	ATC : 20
Barriers	n/a	n/a
Included	Vac. Prep Kit	Vac. Prep Kit
Pump Size	BECKER 250 cbm 10,25,40,50 HP (options)	BECKER 250 cbm 10,25,40,50 HP (options)
Safety fence	optional	optional
X-Drive System	Rack	Rack
Y-Drive System	Ball Screw	Ball Screw
Z-Drive System	Ball Screw	Ball Screw
Rapids/cutting X,Y,Z	X;Y;Z=60/45/24 m/m	X;Y;Z=60/45/24 m/m
Rapids/cutting C, B	B&C=60°/sec 24 m/m	B&C=60°/sec 24 m/m
Positioning Tolerance(No Scales X, Y, Z)	± 0.05 mm/M	± 0.05 mm/M
Repeatability Tolerance(No Scales X, Y, Z)	± 0.03 mm/M	± 0.03 mm/M
Positioning Tolerance(Scales C, B)	± 45 arcseconds	± 45 arcseconds

The MAXXIS MOVE Series Traveling Gantry 5-axis machining centers set a new level of 5-axis accuracy and machining performance. The combination of a highly rigid base, precision gearbox and high accuracy Servo System make the MAXXIS MOVE an ideal choice for machining Long Travel 5-Axis plastics, aluminum and composite materials. The MAXXIS MOVE comes in two machine format configurations.

Flat Table Design

This design utilizes a vacuum grid bed to hold work pieces in place. Vacuum plugs

are quickly removed in the grid table to accommodate a variety of work piece requirements. The solid webbed steel modular base comes in a standard 5' x 12' format, but can be expand to lengths of 24' or beyond on request.

Pod and Rail Design

This design utilizes a sliding vacuum and clamping system that are used to accommodate a variety of specialized clamps and work piece fixtures. The solid webbed steel modular base comes in a standard 5' x 12' format, but can be expand to lengths of 24' or beyond on request.

Design Features

The MAXXIS MOVE 5-axis machining center is designed to handle heavy duty 5-axis machining in wood, aluminum and composites materials.

- Advanced 5-axis CNC features are available on both models
- CNC Controls include Ethernet options to provide remote technical support
- Work piece holding flexibility is provided by optional clamping, grid, or manifold vacuum systems



Large Heavy Duty open machining envelope – Open machining envelope for both large and small parts.



Custom composites and high precision machining applications



Work Holding – Both Flat Table grid vacuum systems and Pod and Rail Clamping systems available for flexible work holding requirements.

OPEN GANTRY BRIDGE 5-AXIS SERIES

THE MASS 5

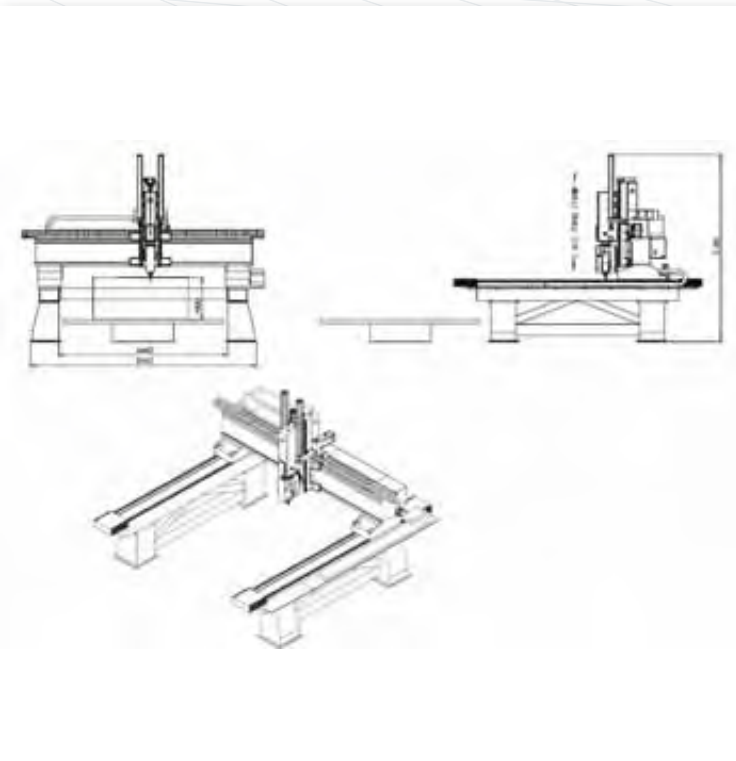

Modular Machine Design – Open Bridge design allows for easy access and part fixturing and part removal.

Basic configuration	Mass 5 Open Gantry 5-Axis
Application	Composites/Aluminum
Table configuration	Open Gantry
Table Style	open, flat steel, T slot
Zones	1 zone
Table Size in mm (metric)	width : 3000 - 6000 mm (118 - 236 in) length : 6000 - 16000 mm (236 - 630 in)
Table Height	optional
Standard Z (stroke) #1	1000 - 3000 mm (39,3 - 118 in)
B and C-axis	B : $\pm 100^\circ$ C : $\pm 200^\circ$
Control	SIEMENS 840D FANUC 31i series
Router Spindle	15 HP (HSK 63F, 22000 rpm) 20HP, 25HP (HSK 63E, 22,000 rpm)
Type ATC	Ranrob : 16, 20, 32
Barriers	n/a
Included	Vac. Prep Kit
Pump Size	BECKER 250 cbm 10,25,40,50 HP (options)
Safety fence	optional
X-Drive System	Rack
Y-Drive System	Rack
Z-Drive System	Ball Screw
rapids/cutting X,Y,Z	X;Y;Z=36/36/12 m/m
rapids/cutting C, B	B&C=60°/sec 24 m/m
Remote Internet Diagnostics	yes
Tool Holders	yes

The Anderson MASS 5 Heavy Duty Open Gantry series 5-axis CNC machining center set a new level of accuracy and machining performance for large scale open gantry machining centers.

The MASS 5 is an ideal choice for large format machining of aluminum and composite materials. The Anderson Open Gantry design allows for maximum work envelope flexibility that can handle very large parts.

Modular Design

Machine frame sizes are available in a number of large format sizes. The open

frame allows for easy access and is configured as a full open bridge design or with an optional steel table or grid vacuum table.

The solid base and substructure remain smooth and rigid while all 5-axis are in full 5-axis machining mode. The highly rigid C and B gearbox are designed for smooth motion and high tensional stability throughout the range of motion.

The large open format and high Z-axis creates a large machining envelop for machining surfaces, pockets, holes and other key machining surfaces to high level of tolerance on all sides. World class five

CNC controls are available on the Anderson MASS 5 HD, as well as optional high precision glass reference scales. Control access from both Ethernet that includes Internet remote technical support.

Work piece holding flexibility is provided by optional clamping, grid or manifold vacuum systems. The MASS 5 HD has an industry standard G-code platform that allows easy interface with all major CAD/CAM software packages. Additional options include work piece dimension probing, both single and multiple zone capabilities and custom configurations upon request.



Custom Aerospace applications



High precision automotive applications



High precision nautical applications



Custom applications for military, satellite and medical industries.

THE NC CUSTOM SERIES

CUSTOM CNC SOLUTIONS



Anderson has the unique capability to combine several CNC technologies to produce custom CNC solutions for specific applications.

Our core CNC competency across several key CNC technologies allows Anderson engineers and manufacturing staff the ability to combine these technologies into cost effective and production CNC solutions.



Core Technologies

CNC Machining and Routing

Technology employed to produce a custom machine solution includes the following:

- Extensive machine design experience
- 3, 4 and 5-axis CNC machine designs
- Vacuum Work Holding designs
- High Speed Machining designs
- Linear Motor Drives designs
- Glass Scales

PCB (Printed Circuit Board Routers and Drills)

Anderson is one of the world's largest manufacturers of PCB machining centers.

Technology employed includes:

- CNC Machining
- CCD Camera Technology
- Tight Tolerance Systems
- Automatic Loading
- Multiple Spindle Design Solutions

Other CNC Technologies

- Micro and Larger Scale CNC Laser Cutting
- Twin Spindle CNC Glass cutting
- Laser Engraving for Solar Panels

Design and Manufacturing Capabilities

Anderson can design and manufacture CNC solutions for a large base of customers and application requirements.

Types for CNC Machines

- CNC Routing
- CNC Composite Machining
- CNC Glass Cutting
- CNC Laser Engraving and Cutting
- CNC Drilling
- CNC PCB Machining

For a custom CNC solution please contact your Anderson representative.



Anderson NC 3535 TC/LV



Anderson's NC series allows for any size machine to be engineered and constructed. Multiple axis machine designs are product specific and completely adaptable to a customers needs in a machining center.



Anderson NC-3116PT/S4 +4



Multiple working heads and spindle configurations are possible to suit a variety of applications.



Taichung Harbor Manufacturing Plant for the design and construction of extra large CNC Machines.

OFFICES AND DIVISIONS

ANDERSON GROUP

As a global enterprise, Anderson has formed alliances with key marketing and service partners around the world. In addition, Anderson has wholly-owned subsidiaries in major world markets.



MARKETING & SERVICE PARTNERS

ANDERSON GROUP



ANDERSON SUBSIDIARIES



MARKETING & SERVICE PARTNERS





ANDERSON GROUP AMERICA

10710 Southern Loop Blvd.
Pineville, NC 28134-8467

Tel: (704) 522-1823

Fax: (704) 522-0871

www.andersonamerica.com

info@andersonamerica.com