

HOMAG: flexTrim – flexibility on top form

Maximum flexibility and reduced operating errors during trimming processes – these are just two of the many benefits of a new HOMAG development, the flexTrim. This innovation provides a solid basis for the latest generation of trimming heads.

With its new trimming unit flexTrim, HOMAG has achieved another major milestone in the field of batch size one production. By applying customer-oriented thinking, HOMAG has succeeded in substantially reducing the quota of operating errors. This is due primarily to the facility of the unit for rapid tool displacement and also to the structure of the trimming head, which is fitted with two trimming tools with different profiles (for instance R2 and R3). Arranged one inside the other, the trimming tool with the larger radius or profile is fixed permanently in the trimming head. The smaller trimming tool is set back and can be pushed forward automatically. This arrangement allows automatic resetting between the two radii and different chamfers to take place within a workpiece gap of just 400 mm. The principle: few profiles, short set-up times and increased productivity – from the woodworking shop through to the industrial manufacturer.

flexTrim is suitable both for use in 4-motor contour trimming units and for 2-motor contour trimming and profile trimming units. The first case involves four trimming motors operating with two differently sized trimming tools each in a single pass. When producing different parts, the tracing function is set in accordance with the edge thickness. Chamfer trimming takes place with a radius run-out of below 15 degrees. The flexTrim trimming head can be mounted on HOMAG contour trimming units.

The new technology represents a major breakthrough in terms of precision, time savings and flexibility. Used in combination with the new

profile scraper blade flex**Blade** for faster profile changing, flex**Trim** opens up enormous scope for additional applications in trimming and profile processing, in particular batch size one production.



Fig.1:
flexTrim trimming head

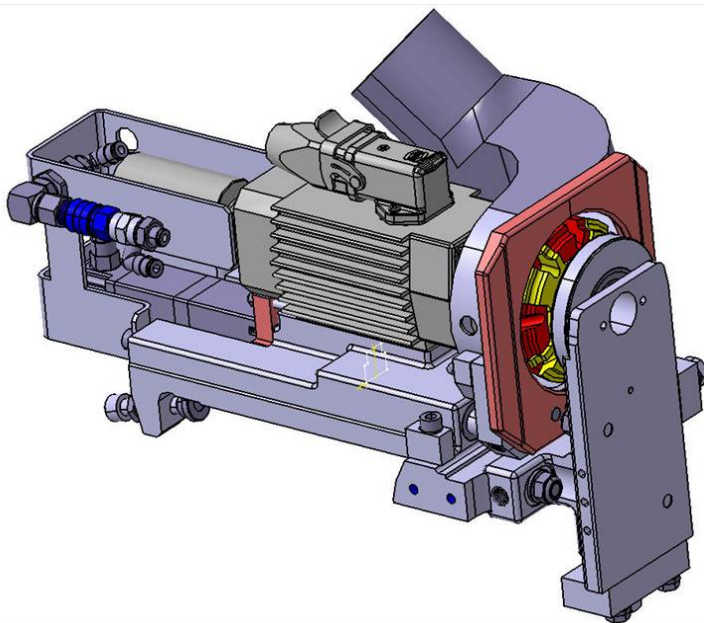

Fig. 2:
Graphic view of the flexTrim trimming head; the two different profiles are highlighted in red and yellow.

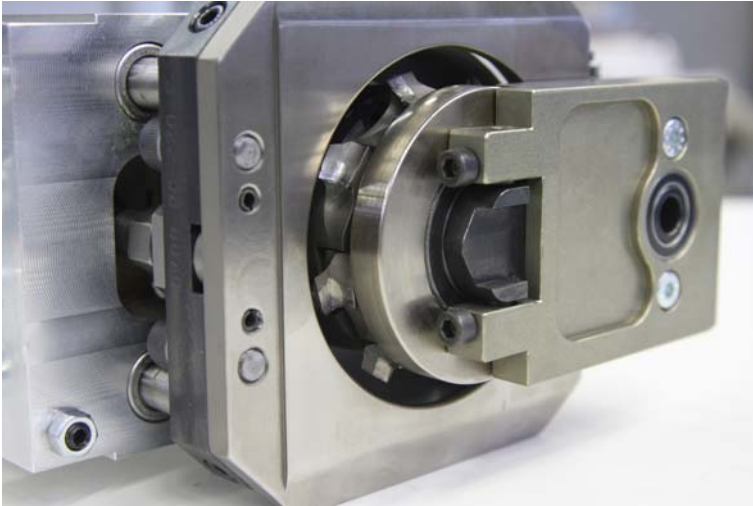

Fig. 3:

Detailed view of the flexTrim tool

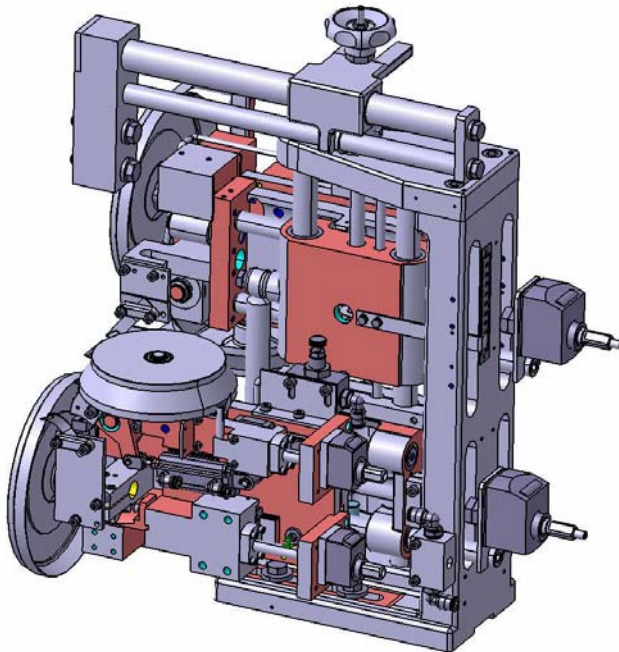

Fig. 4:

flexBlade processing head

For more information, contact

HOMAG Holzbearbeitungssysteme GmbH

Homagstraße 3–5
72296 SCHOPFLOCH
GERMANY
www.homag.com

Alexander Prokisch

Head of Communication
Tel. +49 7443 13-3122
Fax +49 7443 13-8-3122
alexander.prokisch@homag.de

Author

Markus Kostenbader

Product Manager Throughfeed Technology
Tel. +49 7443 13-3119
Fax +49 7443 13-8-3119
markus.kostenbader@homag.de