

ES



Ergon

CNC routing centres

D

S

N



E-mail: contact@caple.in Mobile: (91) 99200 71716

Ergon

CNC
routing centres

Beyond machine concept, to offer a wide range of modular solutions which meet specific manufacturing requirements.

From generic production



To Nesting production



To light alloys and plastic machining



To high productivity



To office furniture production



Up to 5 controlled axes production

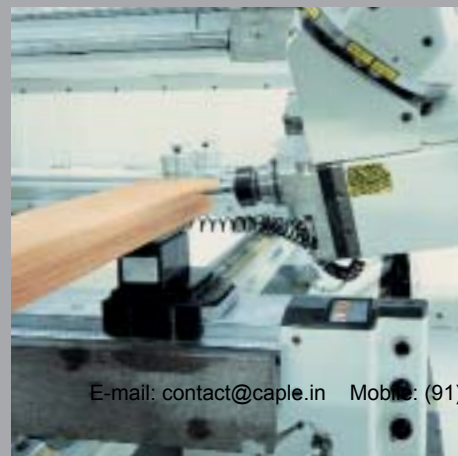

E-mail: contact@caple.in Mobile: (91) 99200 71716

Ergon

High technology for any size of machine required.
The correct production from compact to large table versions



Ergon L

Ease of use and industrial integration. Optimum working conditions to exploit the machine's highest capabilities.



Ergon TVN

The fixed-gantry rigidity combined with the suction cup and bar worktable flexibility.



E-mail: contact@caple.in Mobile: (91) 99200 71716

Ergon

CNC
routing centres

Ergon

The rigidity of the aluminium multi-function worktable combined with the robust structure of the Ergon guarantee an unbeatable quality finish. Ideal for the production of MDF doors and solid wood components, and for Nesting production.



 scm



Ergon
TVN

The flexible solution for tables, office furniture and all types of furniture. Fast set-up times of suction cup and bar worktable combined with fast adjustment of working heads with independent Z axis.



 scm



E-mail: contact@caple.in Mobile: (91) 99200 71716

A wide range of innovative solutions designed to offer a TOP technological standard reflecting on machining and on production.



Rear Unit: the intelligent innovation

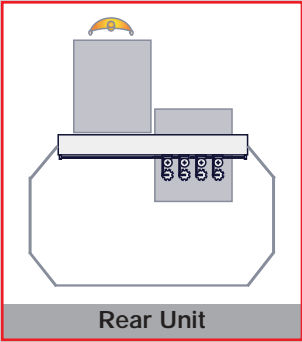
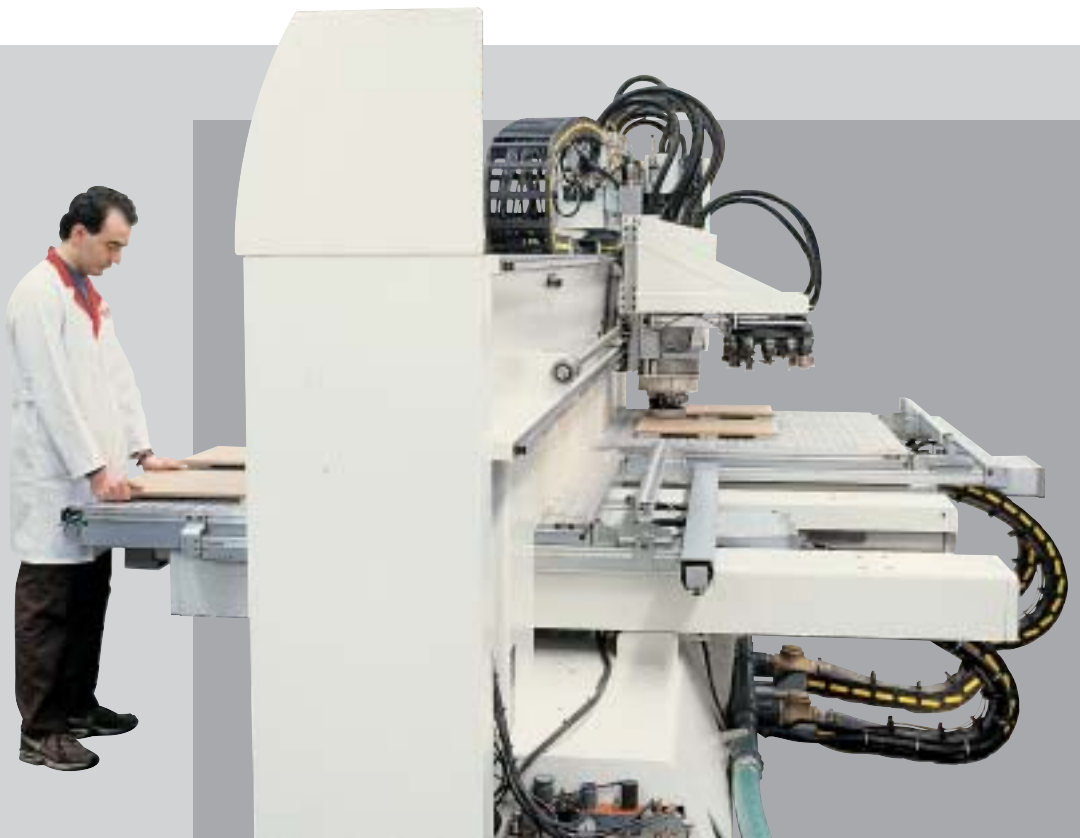

Rear Unit

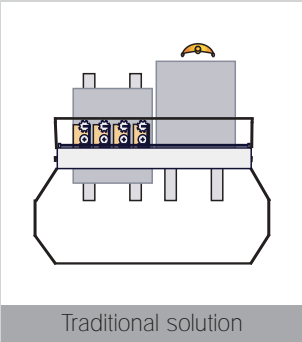

Traditional solution

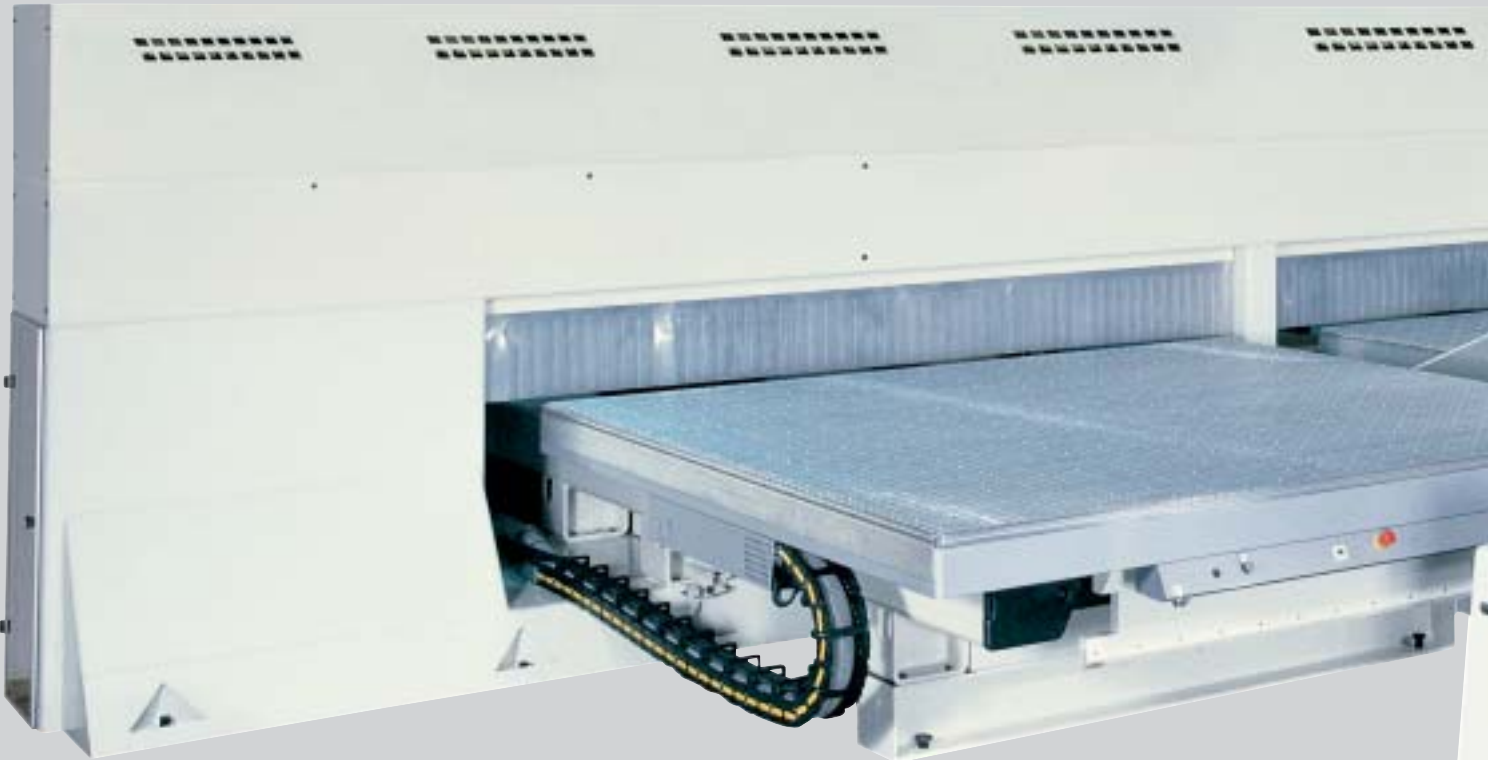



An exclusive and innovative concept with two separate areas : the operator area at the front of the machine and the machining heads area at the rear of the machine for total safety and ease of use.

The machining heads are completely free and totally accessible for maximum ease of retooling.

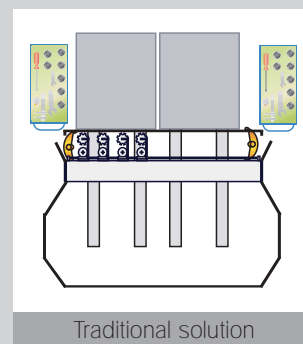
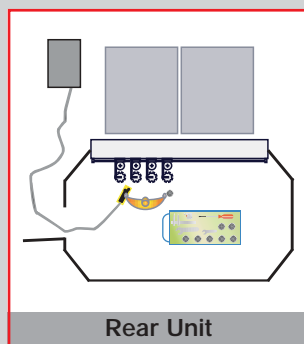
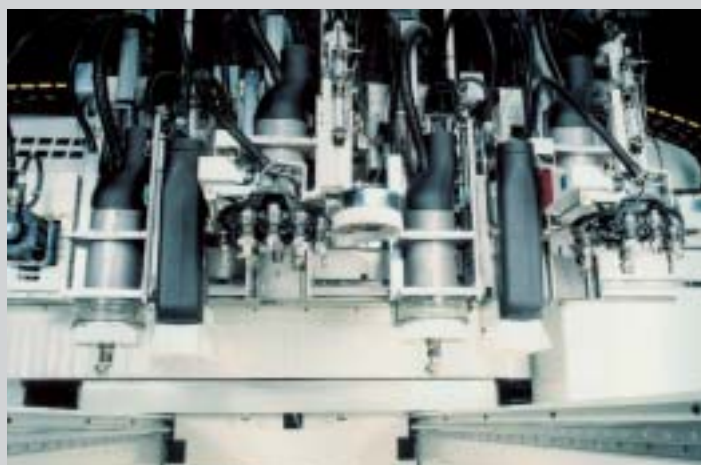

The side guards have large transparent sections and the Rear Unit design enables a complete inspection of test pieces even when the machining heads are in operation. All in complete safety.

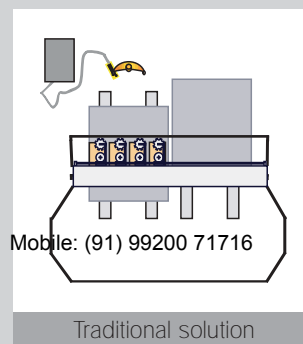
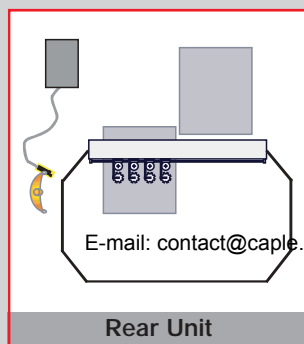

Ergon L

CNC
routing centres

The right
size for each
application



Full access to three sides of the worktable in complete safety while the machine is working. This is the advantage of Ergon L, a practical routing centre ideal for:

- Machining of large and small components with the greatest of simplicity.
- Referencing long components from a side position adjacent to the worktable .
- Cutting down-time by using two or more operators for loading and unloading operations because of machine's high execution speed.

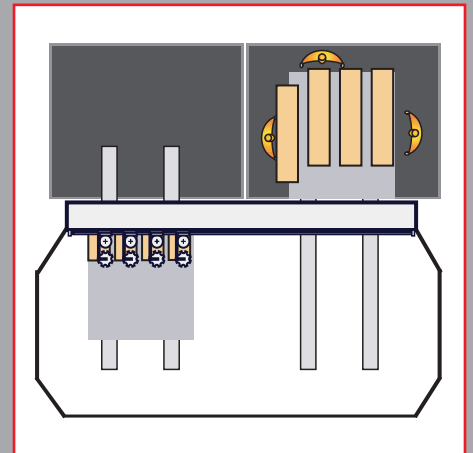

 scm



E-mail: contact@caple.in Mobile: (91) 99200 71716

Independent X axis : complete freedom

An independent X axis means that Ergon can be set up for any type of use adopting the most suitable configuration for each machining requirement.

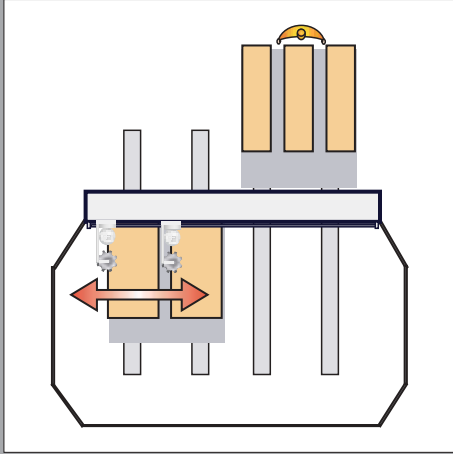

CNC centre-to-centre adjustment in real time.

Adjusting the centre-to-centre to match machining panels, optimises cycle steps and reduces cycle times.

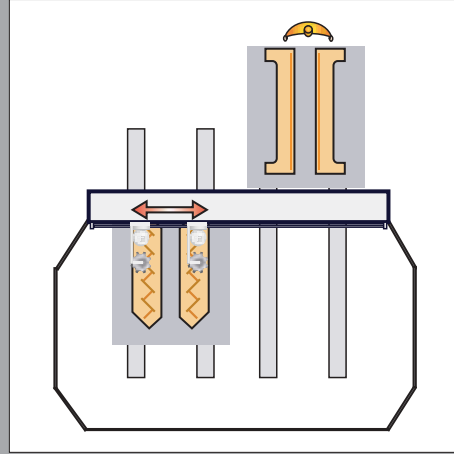

Production of mirrored components.

Ideal for single piece batch production composed of several mirrored components such as staircase parts, cupboard side panels, etc.

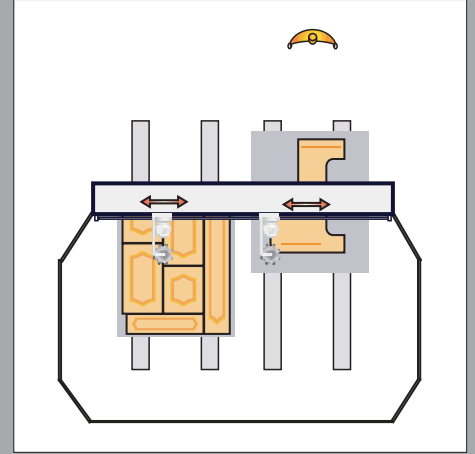

Simultaneous production on two worktables of different components.

During long programs, when only one machining head is being used, the second head can be utilised to machine other components on the second worktable.



Prisma unit: the routing centre revolution



Prisma:

5 controlled axes machining head

- Routing on tilted axes.
- Mitred cuts with sawblade.
- Machining of any profile with interpolation on 5 axes

The Prisma machining unit is the ideal solution for the modern production process.

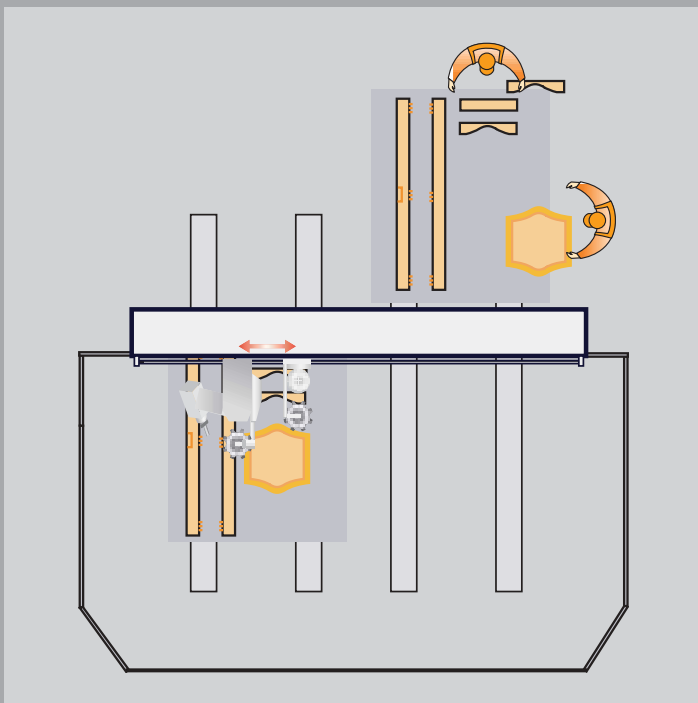

The Basic and Prisma units together.

Power combined with universal use offer a routing centre complete in every function.

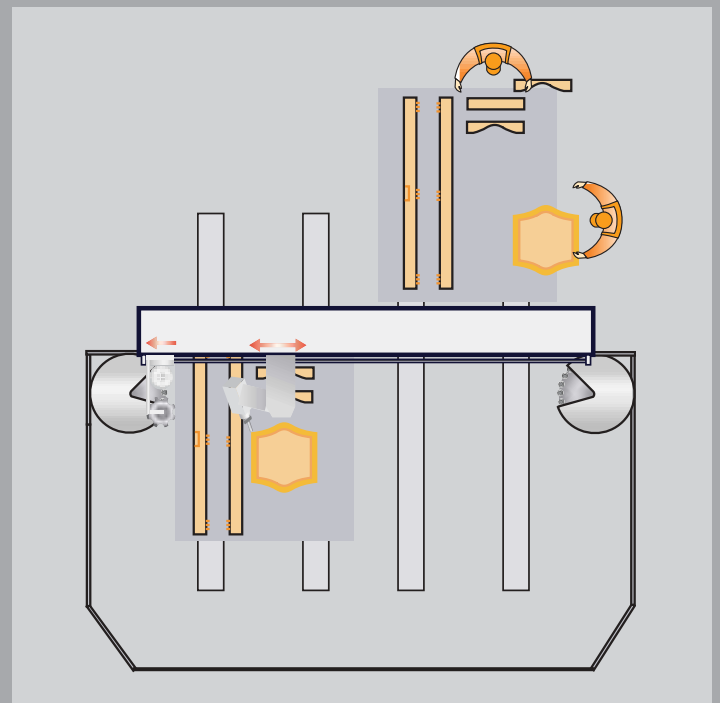

Prisma and Basic with independent X axis.

Flexibility without limits because the side-mounted tool magazines are accessible in masked time during machining.

E-mail: contact@caple.in Mobile: (91) 99200 71716

Independent Z axes: top performance as standard

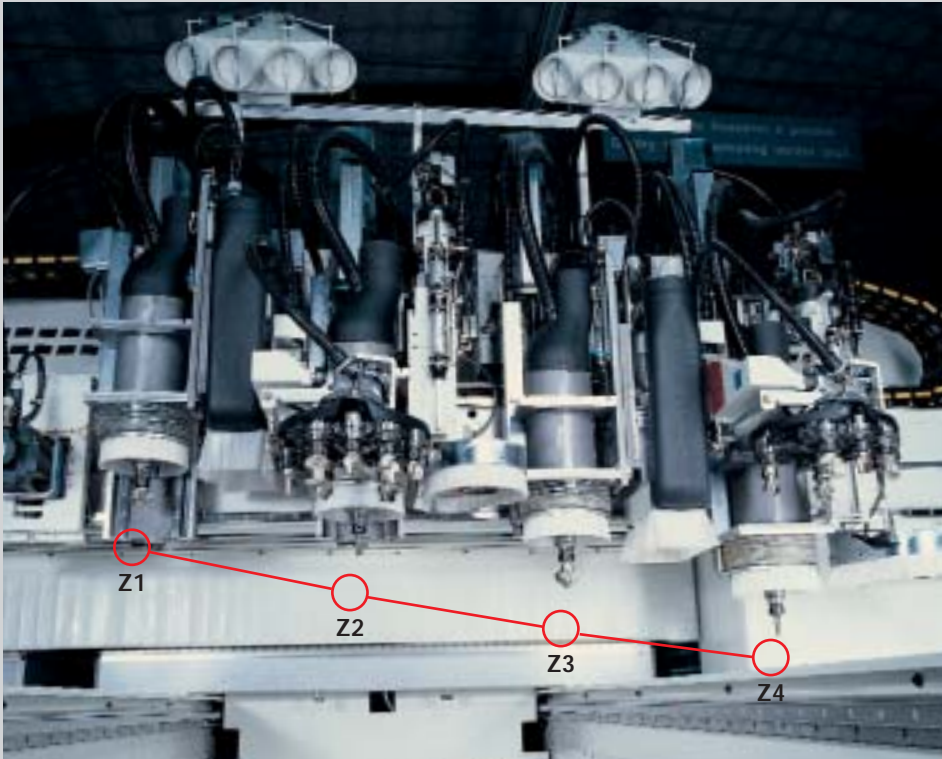

Top level dynamics and precision.
Fast units, driven and balanced separately to ensure a prompt response and maximum positioning precision.

Tool length directly set by software
Tools are set directly on the machine without the need for any presetting in cutter tool holders.

Units connected directly to the cross beam: maximum one-piece rigidity

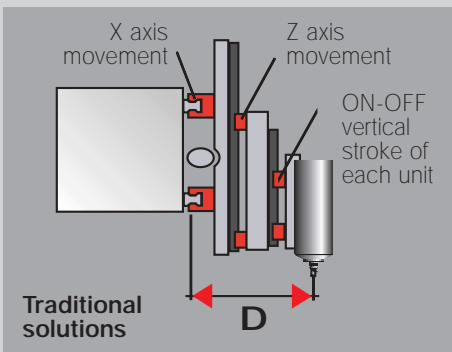

The units are anchored directly to the cross beam without any interface structural components between them.

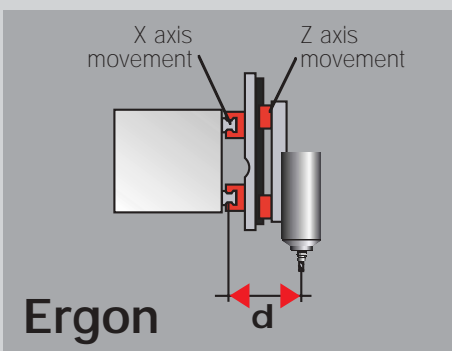

Very short distance between axis, spindle and machine structure.

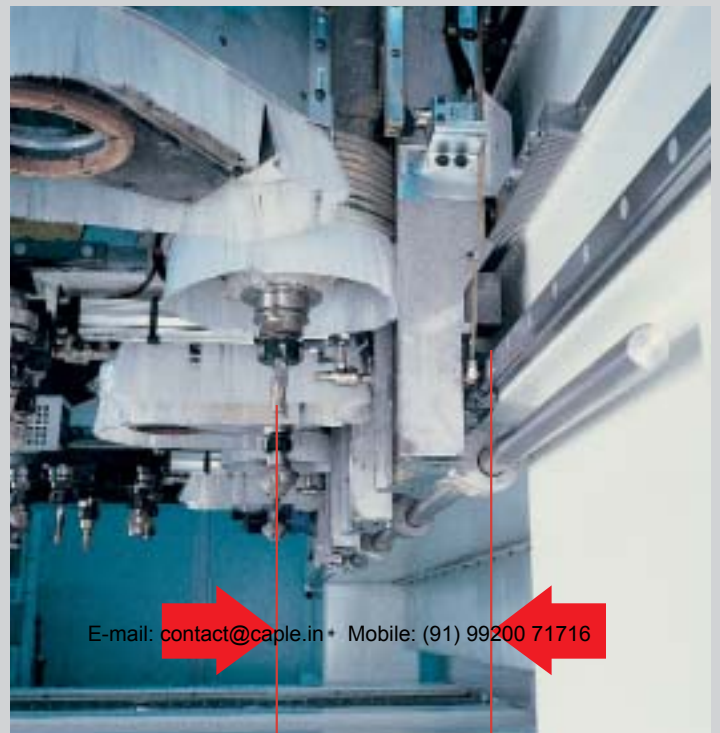

Rigidity and Precision: the unbeatable combination for a high quality product

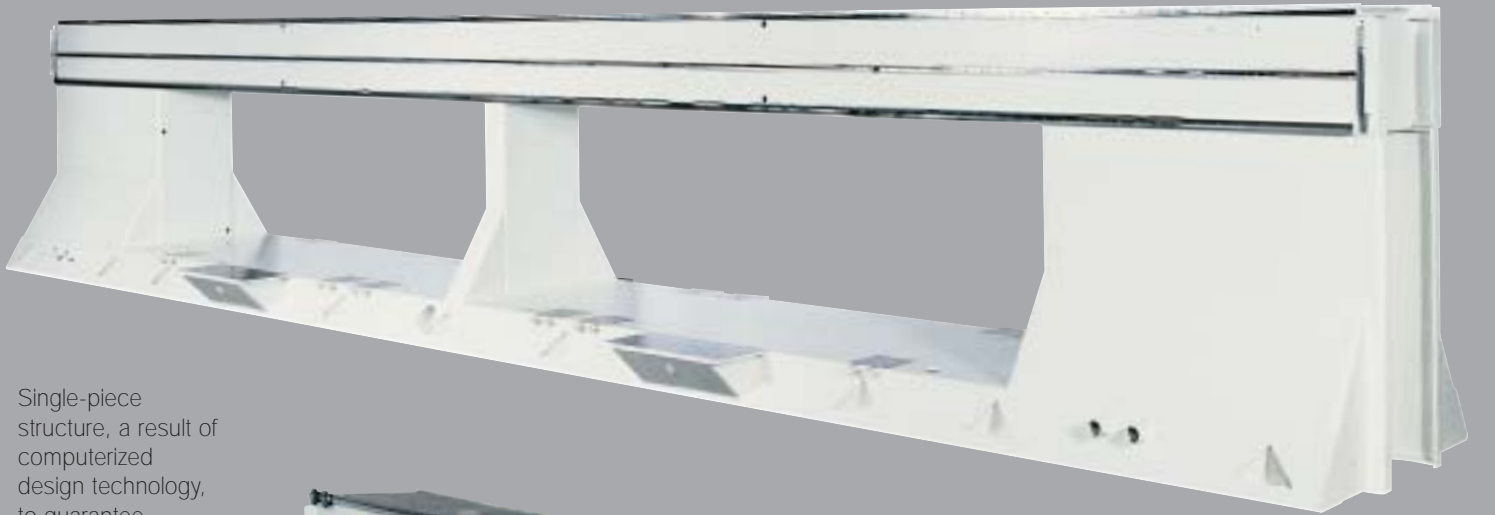

Single-piece structure, a result of computerized design technology, to guarantee maximum rigidity.

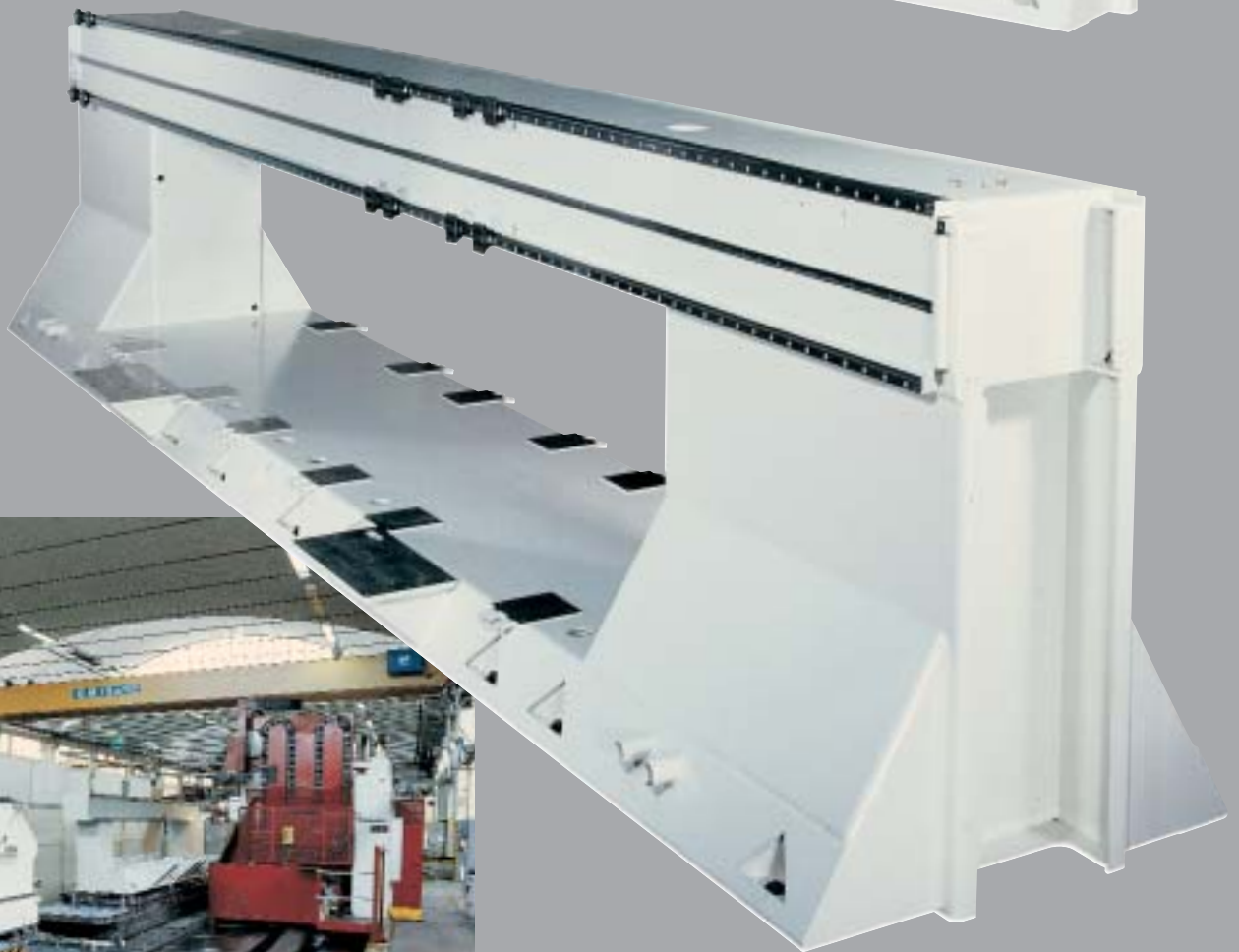

Fully machined in one single location on CNC machining centre, for maximum stability and precision.
E-mail: contact@caple.in Mobile: (91) 99200 71716

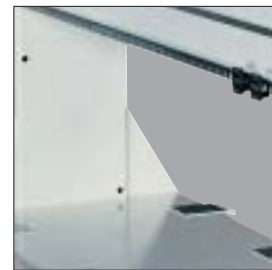

Each machining unit is anchored directly to the cross beam with four high precision recirculating ball bearings. This ensures uniform load distribution, high rigidity and the complete absence of vibration.

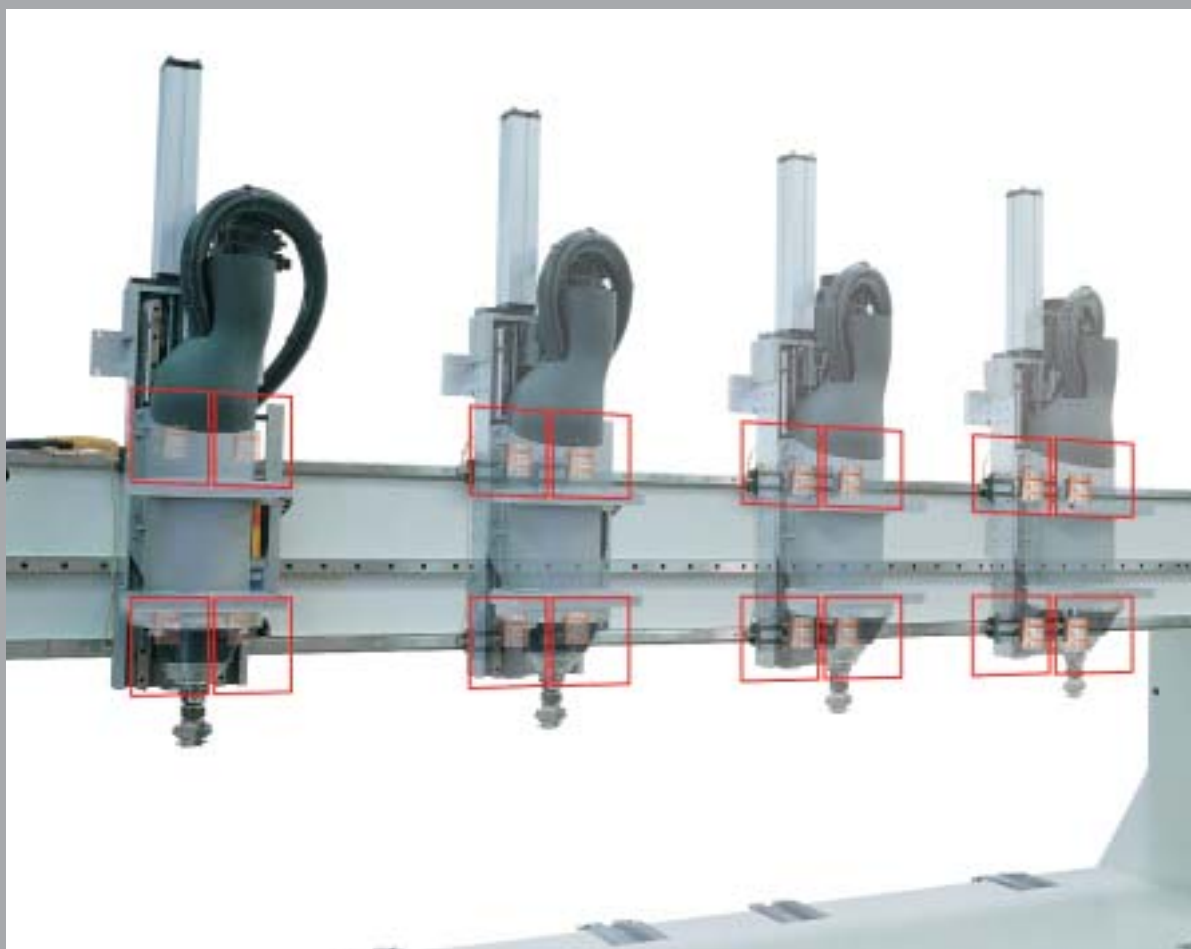

A double rack and pinion drive transmission enables fast, accurate vibration-free movement even with heavy components.

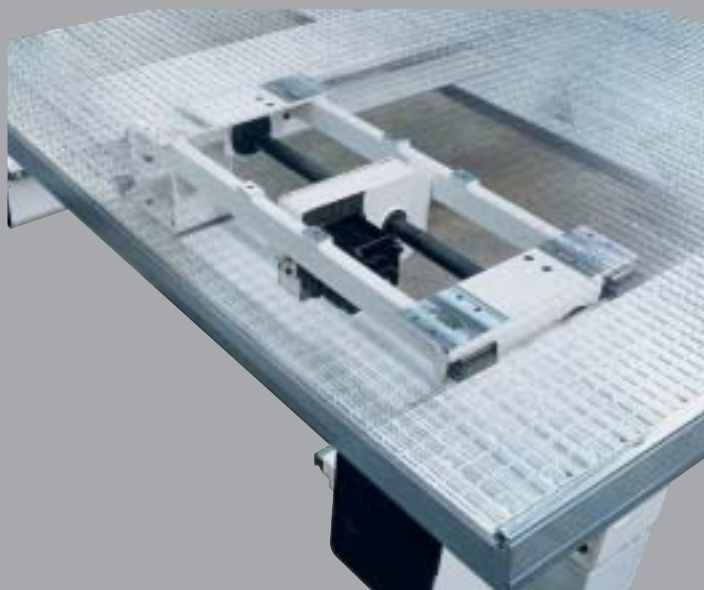

Unparalleled rigidity even on the worktables, thanks to six-point recirculating ball bearing ancorages.

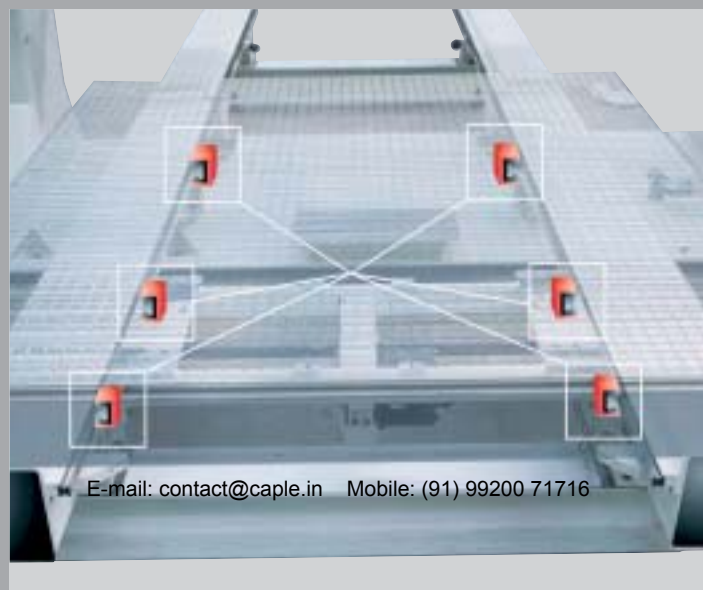

E-mail: contact@caple.in Mobile: (91) 99200 71716

Basic unit:
 maximum rigidity
 and top quality finish

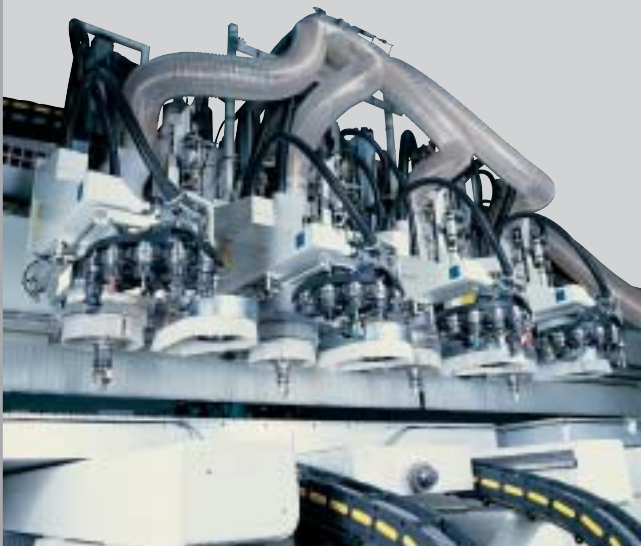

Basic unit:
 7.5-11-15-16 kW
 A 12-station tool
 changer together
 with ON-OFF
 units.
**Productivity
 and flexibility
 together.**

Several profiles can be copied within the
 same cycle using the automatic tool
 changer together with Synchron.



OFF



**Basic unit with
 Plus tool
 changer**
 7.5-11-15-16 kW
 A 12-station tool
 changer together
 with ON-OFF
 units.
**Tool
 changeover in
 masked time**
 while drilling or
 other units are still
 operating.



Tool change



Synchron
 Electronic floating
 copying device for
 continuous,
 heavy-duty use.
 Synchron enables
 surface copying
 without any heavy
 pressure on the
 component. It
 enables full use of
 the tool magazine.
 Unlimited material
 cutting
 parameters.



Modulo unit: maximum flexibility and completeness



Modulo unit:
11 – 15 - 16 kW
A 12-station tool changer together with up to four ON-OFF units.
Maximum flexibility and versatility possible.
Tool changeover in masked time with routing and auxiliary machining.

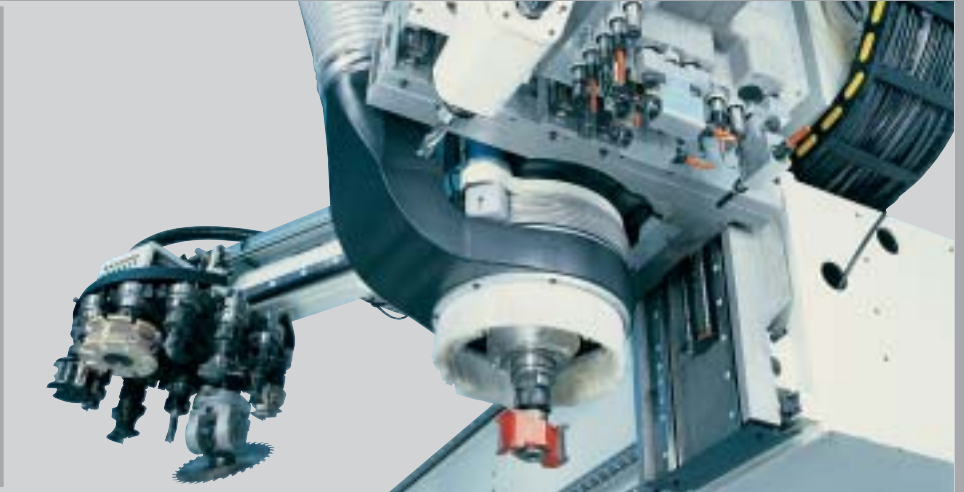

Universal K2 unit
fixed or 0-360° CNC control.
For machining on the horizontal axis.

Drilling unit with 9 (F9) or 18 (F18) independent spindles specifically designed for drilling solid wood and panels.

Saw blade unit 0-90° or 0-360° CNC-controlled sawblade unit. Fast, powerful cutting on any material.

PB1: Supplementary electrospindle for complementary machining. The optimized use of this electrospindle in the machining cycle will reduce the number of tool changes.



Universal M unit With 0-360° CNC interpolation.
The definitive answer to powerful, horizontal machining requirements

E-mail: contact@caple.in Mobile: (91) 99200 71716
Mechanical presser. Reinforcing hold-down when machining overlapping panels.

Compact unit:

the conventional parallel-head design combined with advanced technology



Compact unit 11-15-16 kW

The high productivity of parallel heads combined with the set-up speed of independent Z axes. Together with Synchron C electronic copying device, the Compact unit offers a high productivity solution specifically designed for machining MDF doors.

Synchron C

Synchron C enables the use of higher cutting parameters than those of any other mechanical copying system thanks to the fast response of the working unit with independent Z axis.

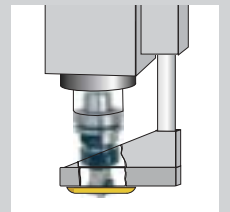

Record set-up times

The Synchron C electronic copying device directly aligns from CNC the tool working dimensions with the ring copying dimensions. This **eliminates all manual presetting times** and means that only one test piece is required to adjust the working height within the CNC.



Downstroke



Alignment



Copying

E-mail: contact@caple.in Mobile: (91) 99200 71716

Specific solutions:
purpose-built units, special angle drive heads
and tool magazines



**Drilling unit
(FZ 26 – FZ 40)**

Up to 40
independent drilling
spindles.
Drilling unit with
independent Z-axis
for heavy-duty
continuous drilling
applications.

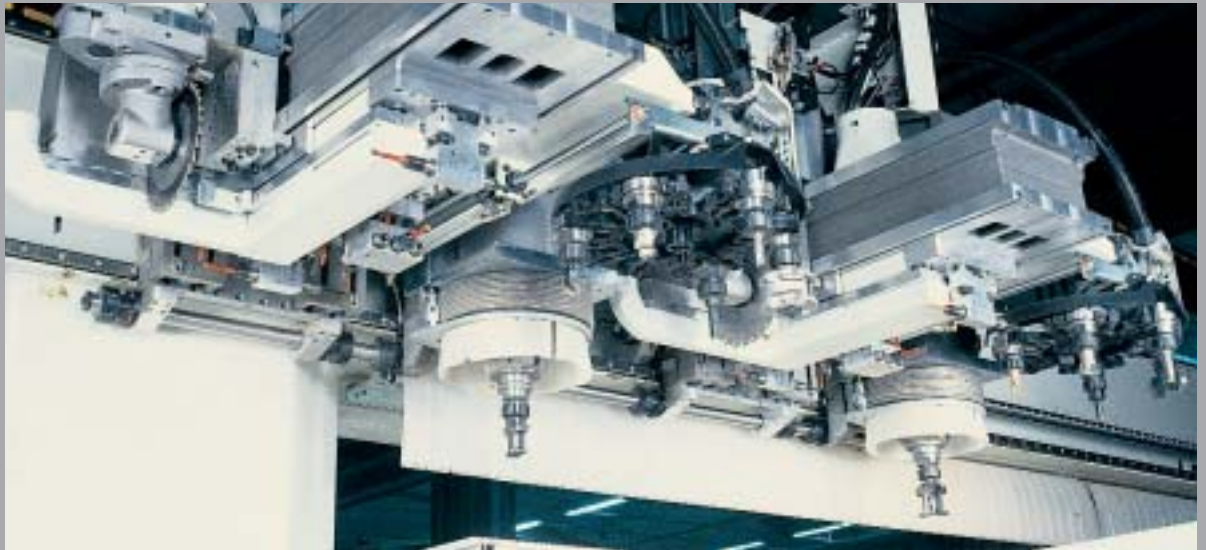

**Vector rotary
axis:**

Flexible solution that
meets the majority
of auxilliary
machining
requirements using
angle drive heads.



Rapid 24:

Side-mounted tool
magazine with 24
tools ready for
immediate use in
addition to the tools
already available
from the standard
magazine.

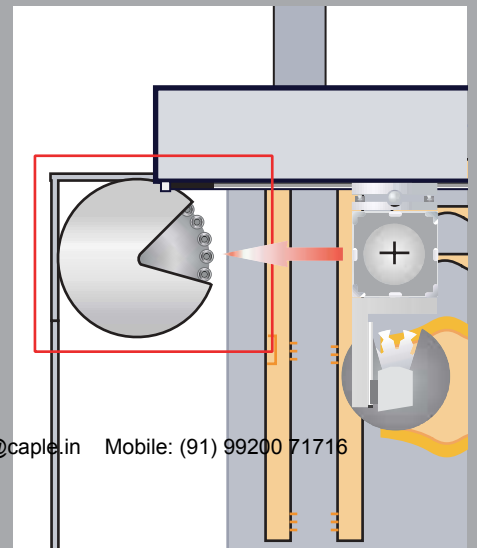

POWER 2000:

Power and reliability
for a top quality finish.



New-generation
SCM POWER 2000
electro-spindle. Powerful.
Strong. Precise. Reliable.

POWERFUL

- Large diameter stator
- Oversized static control inverter for heavy stock removal

STRONG

- One-piece, single-block casing
- Twin pre-loaded bearings
- Large diameter spindle

PRECISE

- Bearings paired during manufacture to ensure maximum precision
- Automatic alignment of the rear bearing

RELIABLE

- Pressurised construction to prevent the entry of dust
- Permanent long-life lubrication
- Liquid cooling

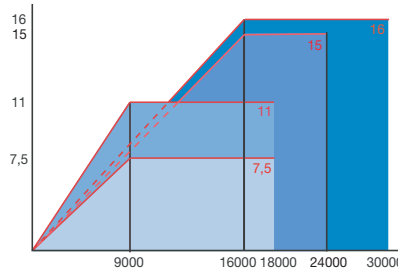

The right power for each application:

- 7.5 kW from 9000 to 18000 rpm
- 11 kW from 9000 to 18000 rpm
- 15 kW from 16000 to 24000 rpm
- 16 kW from 16000 to 30000 rpm

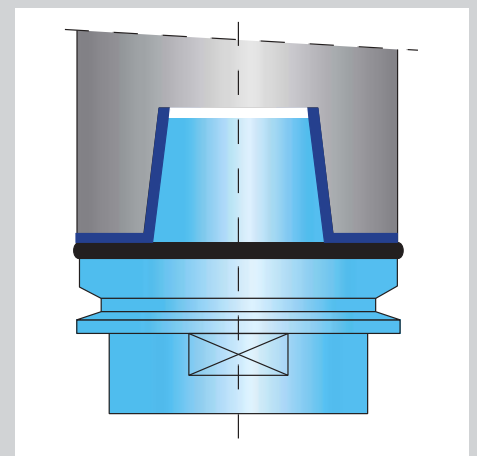

HSK 63 F tool taper which guarantees maximum hold-down rigidity and precision to ensure a high-quality finish for all applications. Exclusive SCM taper cleaning system for precise coupling under any machining conditions.

E-mail: contact@caple.in Mobile: (91) 99200 71716

Multi-function worktable:

a solid base for all types of component clamping



Honeycomb construction:

The work table is constructed utilising aerospace aluminium with a honeycomb structure. This ensures perfect rigidity, flatness and long-life precision. The table design also provides optimum dynamic performance even at fast speeds to ensure a high quality finish at all times.

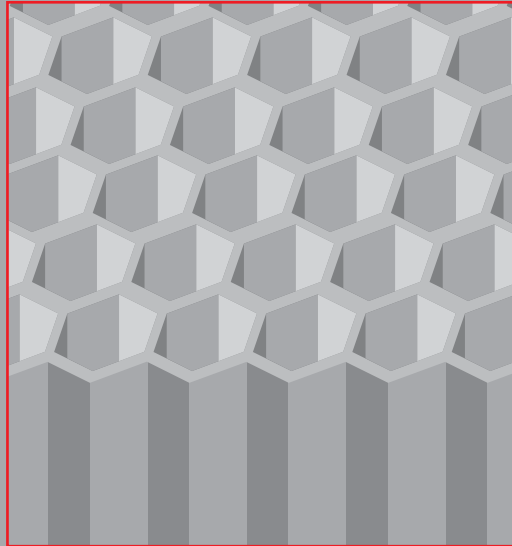

Direct vacuum supply

The table has a direct vacuum supply. The hold-down vacuum travels to all the vacuum connectors through the extruded channels in the worktable. This ensures uniform vacuum distribution and maximum hold-down vacuum power.

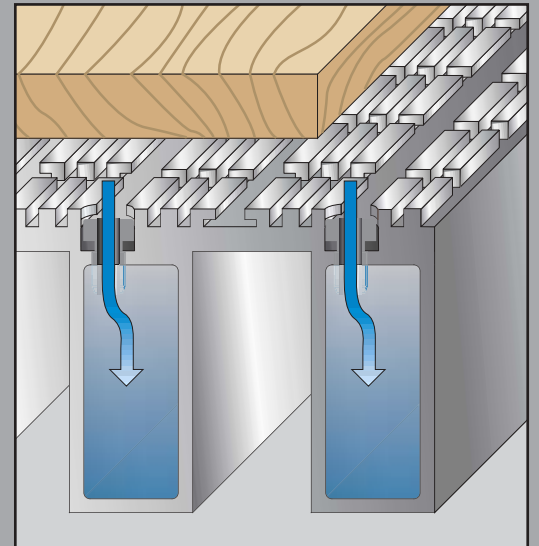

Vacuum:

Vacuum hoses, solenoid valves and pumps are dimensioned to ensure a constant, high vacuum capacity throughout all areas of the worktable.



Multi-function aluminium worktable:

a solid base for all types of workpiece clamping

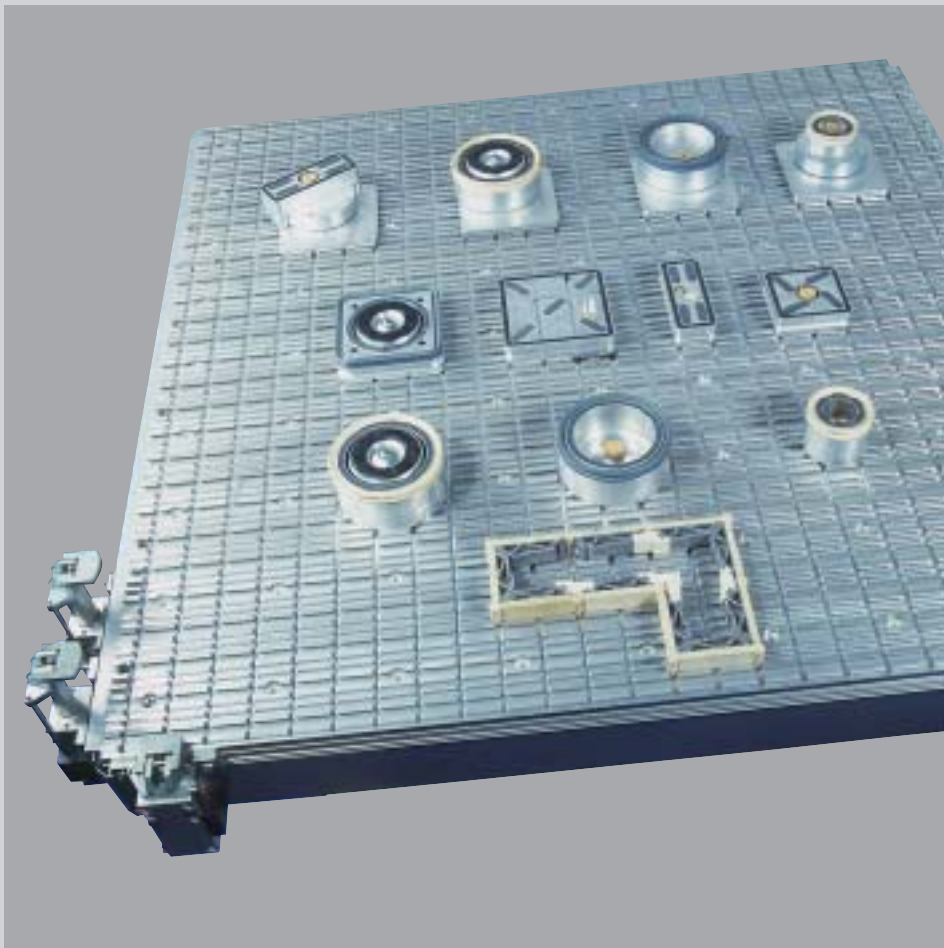

A full range of accessories designed to meet component support, clamping and referencing. Set-up times are drastically reduced.

MPS:
Set-up times reduced to the minimum.

The MPS system reduces worktable set-up times to the bare minimum. When the suction cups are inserted into the grooves of the worktable, an automatic valve immediately starts the vacuum system. Completely free of vacuum supply tubing, the MPS system is extremely easy to use. Using a laser positioning system that guides the operator to all positions, the worktable set-up becomes simple, intuitive and straightforward.

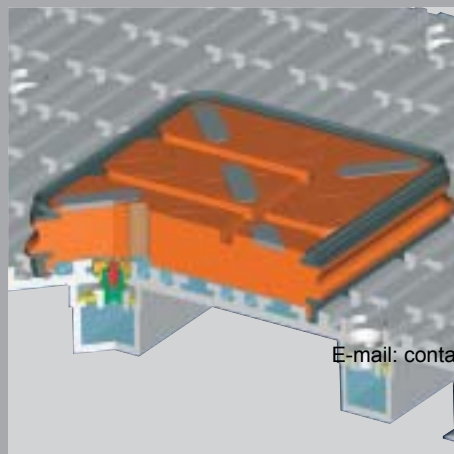

E-mail: contact@caple.in Mobile: (91) 99200 71716

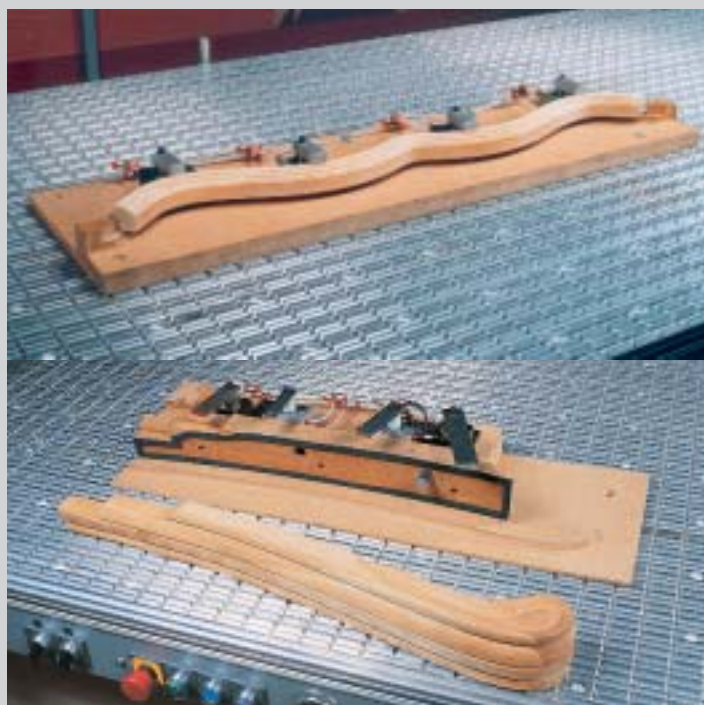

Special inverted T-shaped grooves and threaded holes provide a perfect fixing for all hold-down devices.

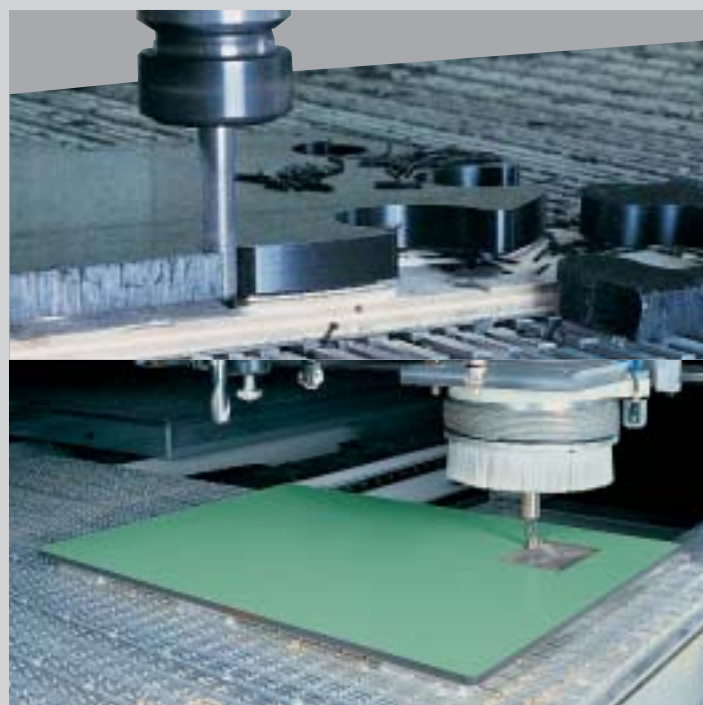

Multi-function aluminium worktable rigidity and flatness make it ideal for machining plastics, resins and light alloys.

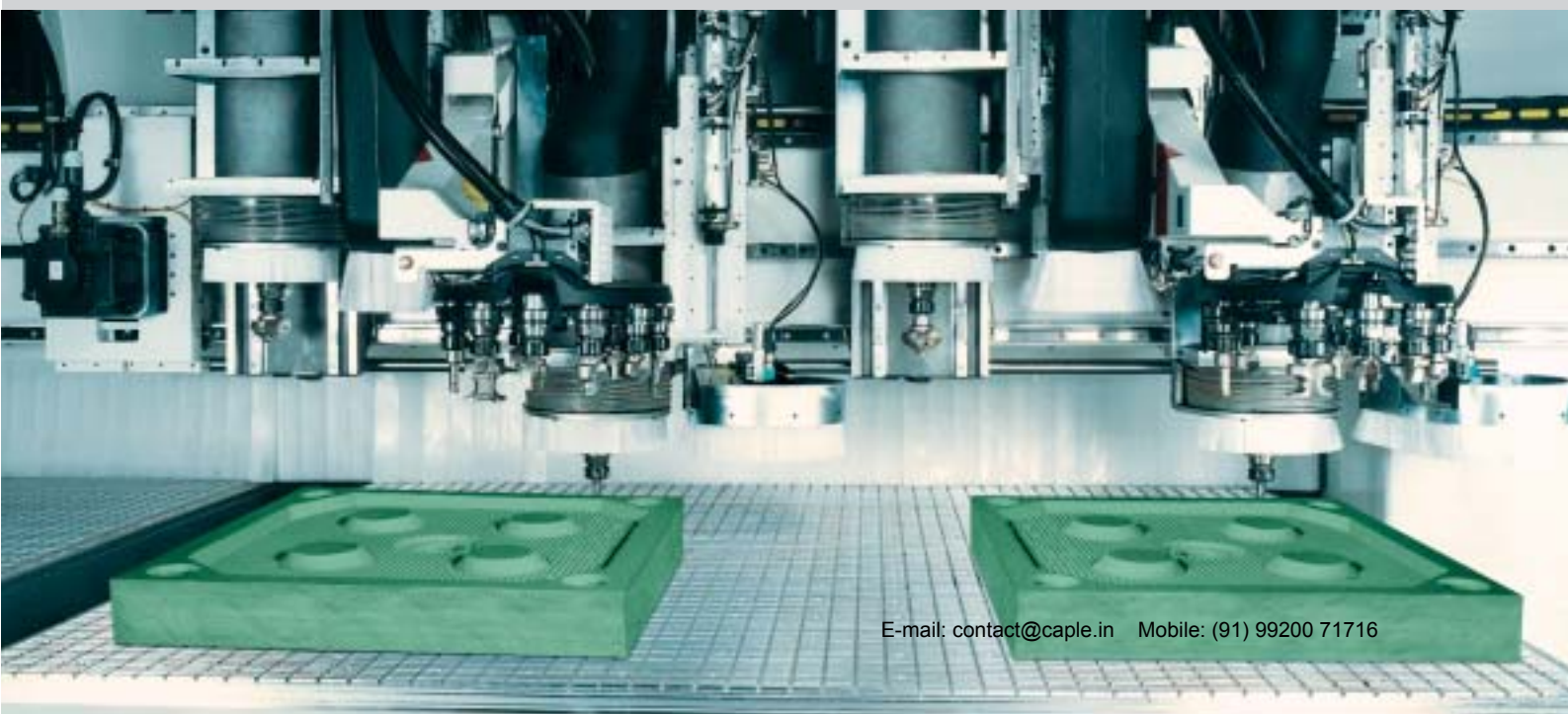

E-mail: contact@caple.in Mobile: (91) 99200 71716

TVN bar and suction cup table:

maximum flexibility
and ease of use



Originally designed for the production of doors and windows, the bar and suction cup table is also suitable for a wide range of other woodworking applications. The TVN system is practical and easy to use because the table is completely free of vacuum hoses and pipes so that positioning and machining of components of any shape is extremely fast and easy.

On the TVN worktable, as many suction cups as required can be added to hold down a particular component. Changing over from suction cups to clamps is quick and easy. Just a few simple operations without the need for tools or special fittings.



Suction cups of any quantity, shape and size can be used, because the table is completely free from vacuum supply hoses.



Pneumatic clamps for solid wood components: solid, secure clamping even when machining at maximum power.



Pneumatic clamps for horizontal clamping.



110 mm high pneumatic clamps: complete freedom when machining from underneath, when using tools with a twin profile and when machining the lower face of a component.

E-mail: contact@caple.in Mobile: (91) 99200 71716



Suction cups specially designed for door uprights, reference stops for veneered components, central references and a complete range of solutions specifically designed to solve all door manufacturer's clamping requirements.

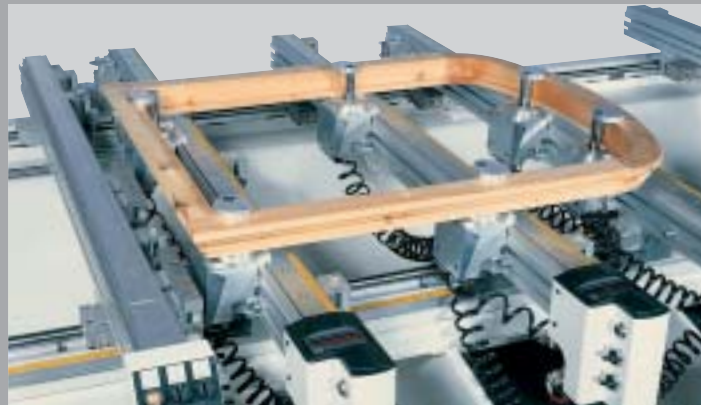

NWT pneumatic clamps: The design of the NWT clamping system is the result of detailed research into the window machining process.



The versatility of the TVN table makes it ideal for the production of designer furniture. The TVN table has a wide range of accessories and suction cups of different shapes and sizes, designed to handle the complex shapes and rounded profiles of designer furniture without any problems.

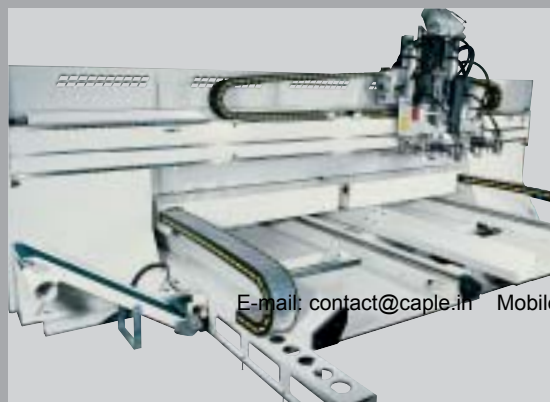

Automatic waste disposal system.

Telecontrol - Xilog Plus - Telesolve: total control

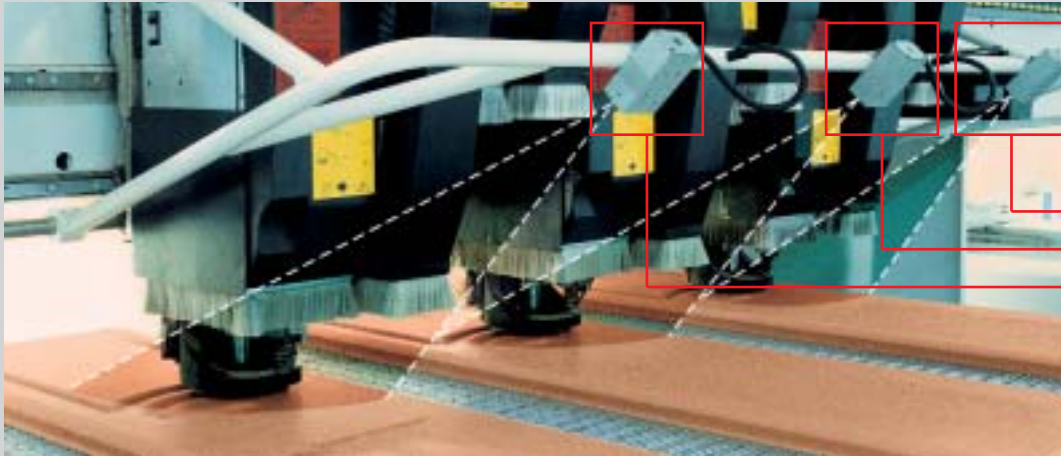
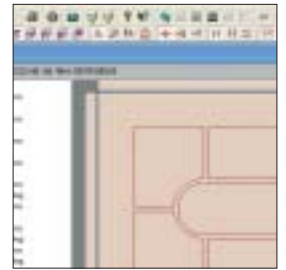

Telecontrol:
full monitoring and control at all times.

A video camera system positioned in front of the machining heads videos the operating areas of the machine. In the operator position, camera images are shown on a practical display making it possible to monitor all stages of the machine cycle in complete safety.

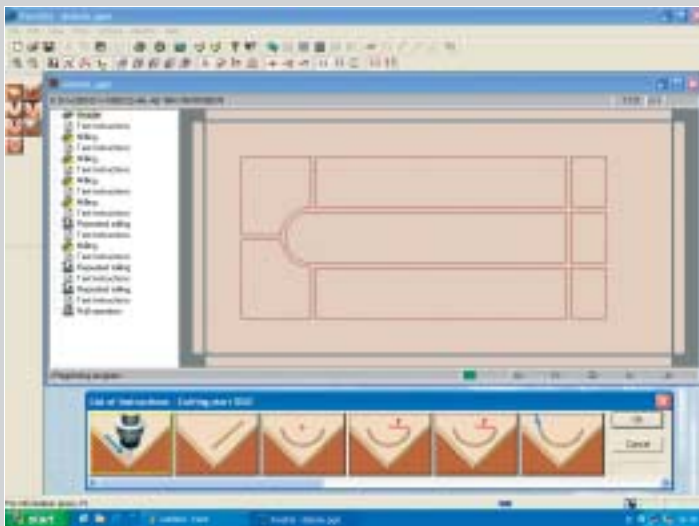

Operator interface with graphics to enable machine programming and control even easier.

- Machine functions handled using a practical and fast control panel
- Programs can be generated even without deep technical knowledge using an Editor with graphical icons and examples on films. Completely realized using Windows operating system.



CNC and OFFICE PC

A high-power CNC on an office PC with a Windows interface. A cost-effective solution combining **high-power processing and ease-of-use. The perfect combination at last.**

This solution means you can use the CNC for all the functions normally handled by a PC:

- Internal company network connections
- Adding data from a floppy disk or CD-ROM and remote connections by modem to the Telesolve system offered by SCM.

TELESOLVE

A remote diagnostics system which allows the SCM assistance service. E-mail: contact@caple.in Mobile: (91)-9920071716 or:-

- PLC logic diagnostics, machine parameter diagnostics, etc.
- Real time updating of the CNC software.

The advantage to always find the right configuration

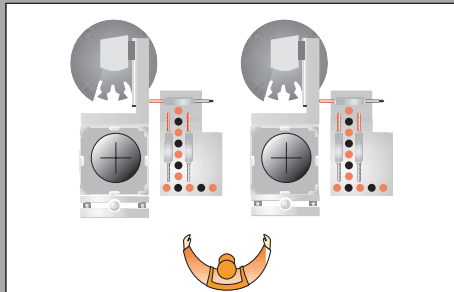
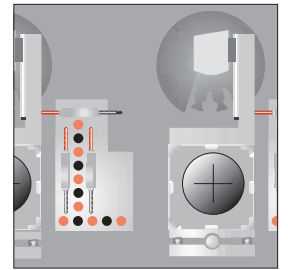

Basic unit with Plus tool changer + F 18 (centre-to-centre 840 mm). General purpose routing and drilling

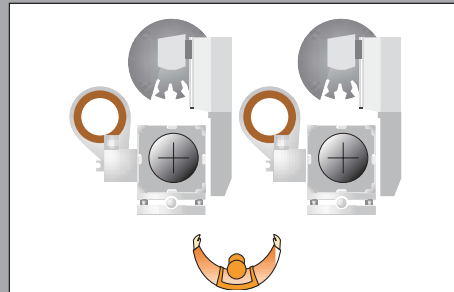

Basic unit with tool changer + Synchron (centre-to-centre 720 mm). Flexible production of doors, with copying system

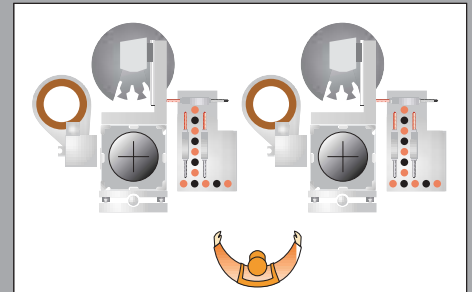

Basic unit with Plus tool changer + Synchron + F 18 (centre-to-centre 1080 mm). General purpose production, with copying system

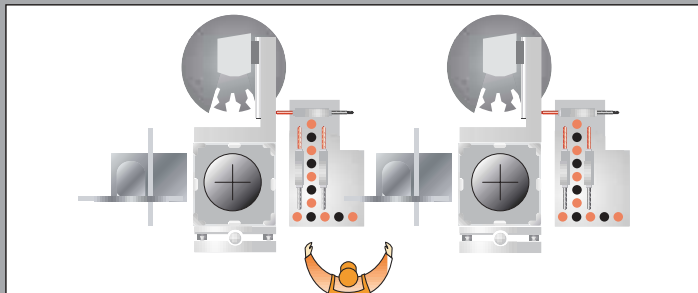

Basic unit with Plus tool changer + saw blade unit + F 18 (centre-to-centre 1080 mm). For furniture production

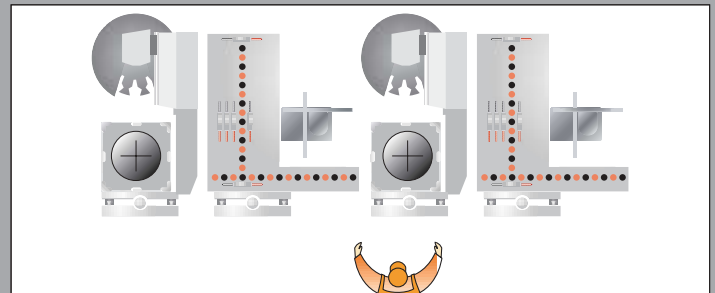

Basic unit with tool changer + FZ40 with independent Z axis and sawing blade (centre-to-centre 1200 mm). For heavy-duty drilling applications

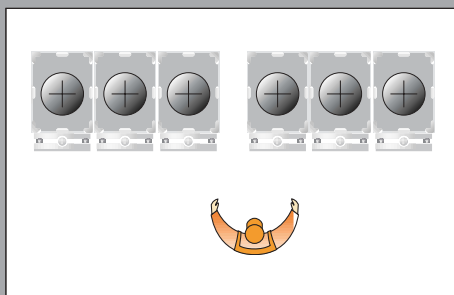

Compact units (centre-to-centre 220 mm each). Series production of cupboard doors

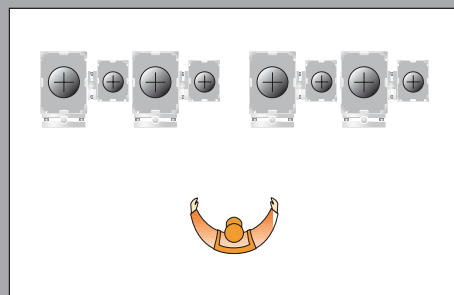

Compact units + PB1 (centre-to-centre 360 mm.). Series production of cupboard doors

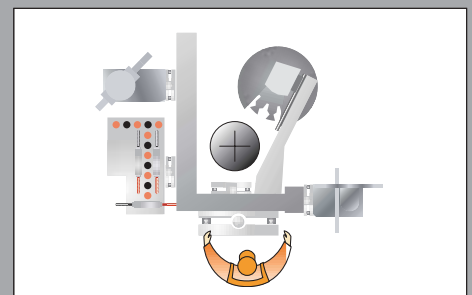

Modulo units + F18 + sawing blade unit + Universal K2. High flexibility production

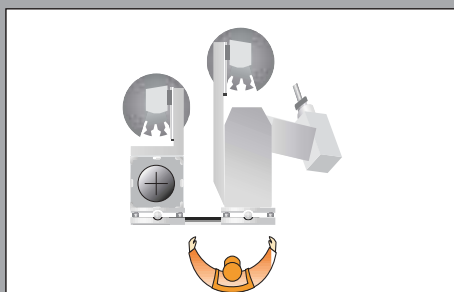

Basic unit with Plus tool changer + Prisma unit with tool changer. Power and versatility on 5 axes

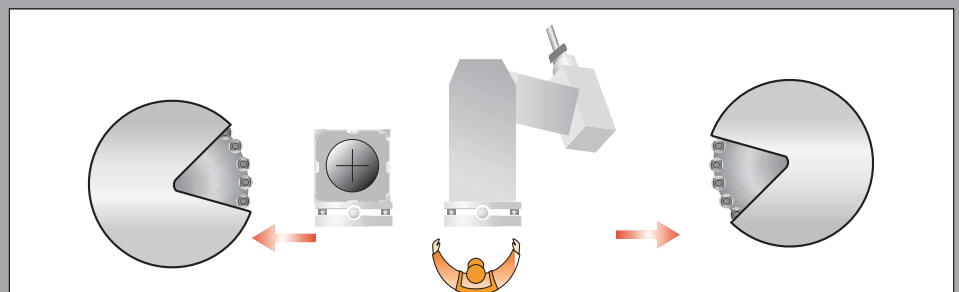

Basic unit + Prisma with independent X axis + Rapid 24 lateral magazine:
The power and versatility of a 3-axis unit combined with a 5-axis unit. High tool capacity thanks to side mounted 24 station tool magazines.

E-mail: contact@caple.in Mobile: (91) 99200 71716

Overall dimensions

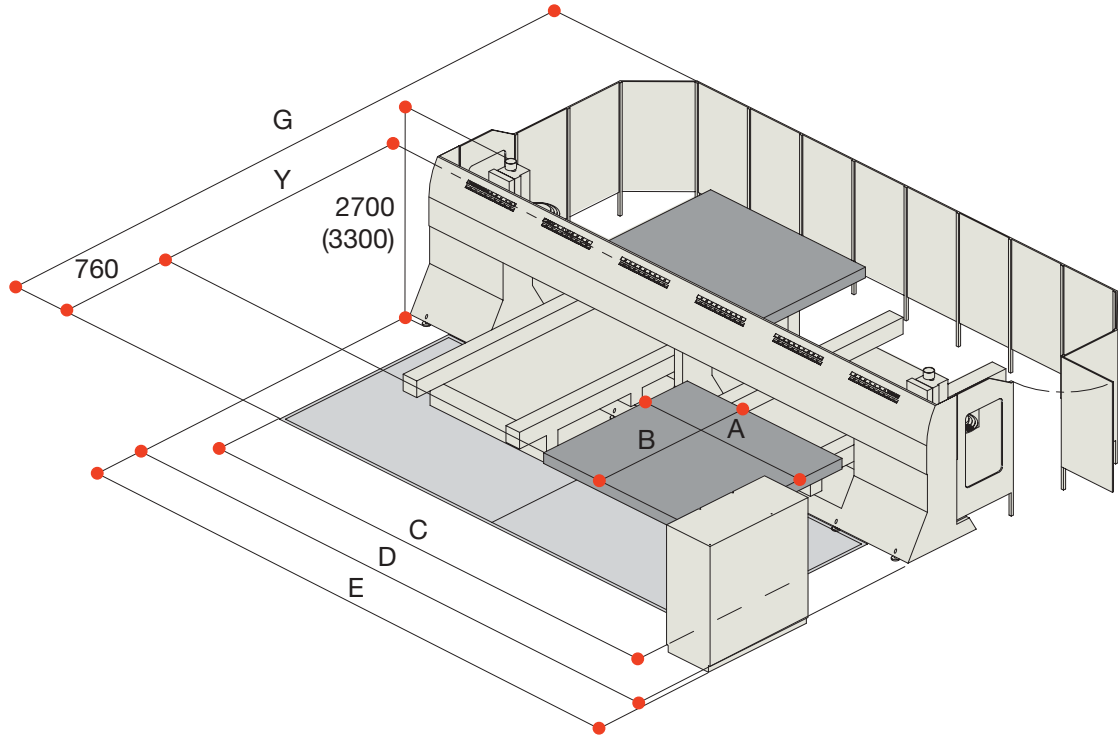

Version	Worktable		Worktable axis stroke		Other dimensions			
	A	B	X	Y	C	D	E	G
Ergon	1525	1560	4845	2080	4860	6300	6500	6085
	2125	1560	6045		6100	7500	7700	5865
	2845	1560	7685		7660	9150	9350	6190
Ergon L	1525	1560	6045	2080	6110	7500	7700	5865
	2125	1560	7685		7660	9150	9350	6190
	2845	1560	8635		8610	10100	10300	6190
Ergon TOP	1525	1560	4845	2650	4860	6300	6500	5655
	2125	1560	6045		6060	7500	7700	5825
	2845	1560	7685		7700	9150	9350	5655
	1525	2160	4845	3250	4860	6300	6500	6625
	2125	2160	6045		6060	7500	7700	6905
	2845	2160	7685		7700	9150	9350	6730
	1525	3120	4845	4490	4860	6300	6500	9085
	2125	3120	6045		6060	7500	7700	9255
	2845	3120	7685		7700	9150	9350	9085
Ergon L TOP	1525	1560	6045	2650	6110	7500	7700	5655
	2125	1560	7685		7660	9150	9350	5825
	2845	1560	8635		8610	10100	10300	5655
	1525	2160	6045	3250	6110	7500	7700	6625
	2125	2160	7685		7660	9150	9350	6905
	2845	2160	8635		8610	10100	10300	6730
	1525	3120	6045	4490	6110	7500	7700	9085
	2125	3120	7685		7660	9150	9350	9255
	2845	3120	8635		8610	10100	10300	9085
Ergon TVN	1500	1550	4845	3200	5000	6300	6650	7000
	2100	1550	6045		6200	7500	7850	7170
	2800	1550	7685		7850	9150	9500	7000
	1500	1850	4845		5000	6300	6650	7200
	2100	1850	6045		6200	7500	7850	7370
2850	1850	7685		7850	9150	9500	7200	
Ergon L TVN	1500	1550	6045	3200	6200	7500	7850	7000
	2100	1550	7685		7850	9150	9500	7170
	2800	1550	8635		8800	10100	10450	7200
	1500	1850	6045		6200	7500	7850	7000
	2100	1850	7685		7850	9150	9500	7370
	2850	1850	8635		8800	10100	10450	7200

Technical specifications:

Component passage	260 mm
Axes speed	X = 105 m/min
	Y = 80 m/min
	Y = 130 m/min (TOP versions)
	Z = 25 m/min
Accelerations	X = 10 m/sec ²
	Y = from 4 to 6 m/sec ²
	Y = 10 m/sec ² (TOP versions)

Some photos show machines fitted with accessories. This is for purposes of illustration only and the configurations shown are in no way binding. We reserve the right to modify technical data without prior notice. Modifications in no way influence compliance with CE-mark safety requirements.

Safety first and foremost



Noise emissions

Ergon	No-load operation without extraction equipment	Machining
Average noise level on measurement surface dB (A)	67,7	81,8
Emitted noise level dB (A) [mW(A)]	86,7 [0,5]	100,8 [12,0]
Noise level at operator position dB (A) [dBmax]	67,7	84,4 [91,0]

E-mail: contact@caple.in Mobile: (91) 99200 71716

Woodworking machinery: the widest range of products

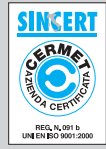

SCM has been producing woodworking machinery for more than 50 years and represents the nucleus of SCM Group. With a total of 3000 employees, 15 factories and an export of 70%, this Group is one of the world's top producers of woodworking equipment. SCM produces the widest range of machines for secondary wood machining, from machines for small woodworking companies to CNC work centres, to high production integrated lines for the machining of solid wood. SCM is certified according ISO 9001 Standards. Specialized technicians all over the world are able to supply an efficient and rapid after-sale service to SCM customers because full use is made of a system of remote computerised diagnostics. SCM can also utilize an internal structure of SCM Group, the CSR-Study and Research Consortium. CSR-Study and Research Consortium uses advanced experimental systems. This ensures that all machines satisfy the strictest international standards in terms of safety, ergonomics and environmental hygiene.

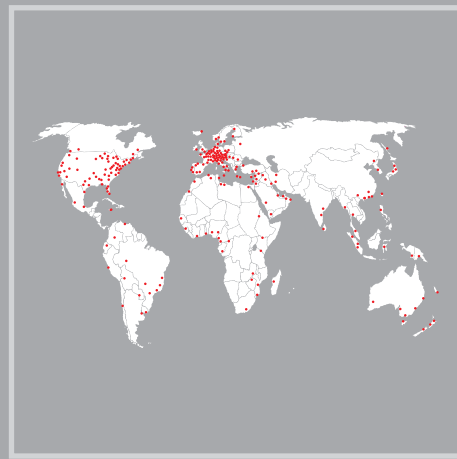

E-mail: contact@caple.in Mobile: (91) 99200 71716

SCM



E-mail: contact@caple.in Mobile: (91) 99200 71716

SCM GROUP spa - Via Emilia, 71 - 47900 Rimini (RN) - Italy
Tel. +39/0541/700111 - Fax +39/0541/700181 - www.scmgroup.com - E-mail: scm@scmgroup.com



Head Office Caple Traders , 6, 7, 8 Kedia Chambers, Opp. Old Police Station, Near New Era Theatre, S.V. Road, Malad (W), Mumbai – 400064.
Tel: 022-28825542, 28894090, 28898531 | Fax: 022-28899725 | E-mail: web@caple.in | Website: www.caple.in

Demo Centre Caple Traders, Navdurga, Shah Arcade Building No. 8, Near Rani Sati Flyover, W.E. Highway, Malad (E), Mumbai - 400 097.
Tel: +91-22-28803584, 28803586 | Fax: +91-22-28441071 | E-mail: web@caple.in | Website: www.caple.in

Query Sheet

Company Name & Address -

Delivery Name & Address -

Contact Person -

Designation -

Mobile No -

Fax No -

Mail Id -

Item -

Model No (If Known) -

Capacity Size -

Application -

Expected Delivery Time -

Notes -

E-mail: contact@caple.in Mobile: (91) 99200 71716

