

4D - high-end
sawing centre

CONTROL

EVOLUTION

STANDARD

COMPACT

■ STRIEBIG ■



COMPACT

Flexible and economical.
Entry into vertical sawing technology.

From vision to market leadership

50 years of successful company history: the "simple" panel saw becomes an all-purpose standard machine for all sawing and grooving work. The vision of our company founder, Ludwig Striebig, has become reality!

Standstill is unknown to us. Every single day we continue to work on the optimisation of the vertical sawing technology. Striebig AG is the only manufacturer of vertical panel saws in the world which exclusively specialises in this individual product category. Therefore we probably have the most comprehensive expertise!

Our vertical panel saws stand for excellent user benefit, spirit of innovation, durability and proverbial "Swiss precision".



Built corporate identity: the facade of the corporate headquarters in Littau near Lucerne features vertical aluminium pilaster strips that form an excellent point of reference with our products and market partners.

The sizing cut principle

The principle of all Striebig panel saws is the sizing cut. Our commitment is the perfectly fitting, dimensionally accurate edge that is ready to be glued. Thinking and acting holistically in all of our company processes is our guarantee for sharp-edged and precise cuts.

The overall economic and ecological context is always the focus of our activities. Our entire company is certified for its management systems in the areas of quality, environment, occupational health and safety. We thus create sustainable values the STRIEBIG, synonym for vertical panel saws.



"Classic and prize-winning" Striebig design: saw unit and control box of the COMPACT AV. Ease of use has always been a Striebig trademark.



The principle of the sizing cut in perfection. Especially the manufacture of high-quality furniture and interior fittings requires precisely cut edges which are ready to be glued as essential quality criterion. Ideal tool for this task: Striebig COMPACT.



COMPACT

Our title picture shows the Chapel Bridge in Lucerne. The Chapel bridge, the oldest wooden bridge in Europe, with its rich series of paintings and water tower is the undisputed landmark of our city.

Essential advantages of the "vertical system"

Space-saving, precise and efficient – the vertical sawing technology is the perfect combination of precision and economy. In many fields of application, it is the only possible, cost-effective and space-saving solution for panel cutting. Vertical panel saws offer benefits which often cannot be realised by horizontal cutting centres.

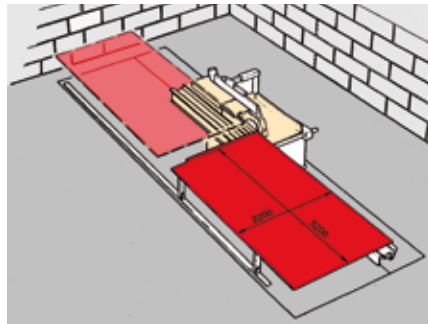
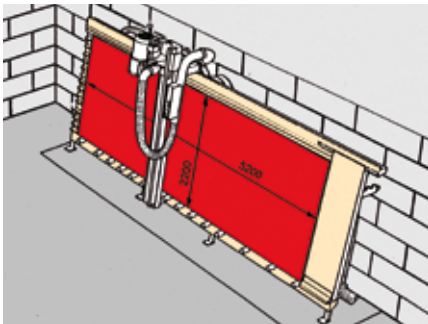

■ Advantages with regard to spatial requirements

The vertical panel saw needs approximately half the space of a horizontal cutting centre for handling the same panel size. Considering the spatial requirements for the panel storage, as well, the spatial advantage of the vertical sawing technology becomes even more apparent.

	vertical panel saw	horizontal panel cutting system
Spatial requirements	100	up to 185
Fixed costs p.a.	100	up to 148
Variable costs/hour	100	up to 154

■ Advantages with regard to price/performance ratio

3:0 in favour of the vertical panel saw. It offers clear advantages over the horizontal panel cutting centre with regard to the cost-benefit contemplation.

■ Advantages with regard to precision and sawing technology

The Striebig saw frame is torsionally rigid and guarantees absolute parallelism between upper guide rail, central support and lower roller support. Another advantage: the panel is absolutely reliably positioned so that no "unclean saw cut" can occur.

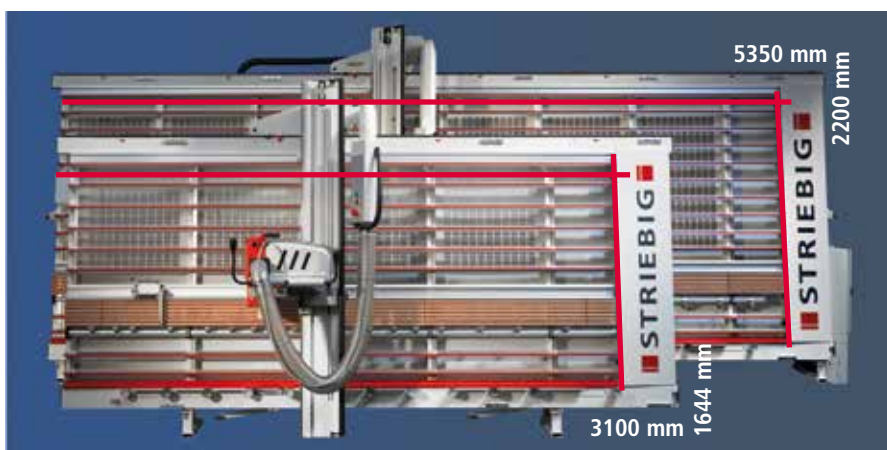
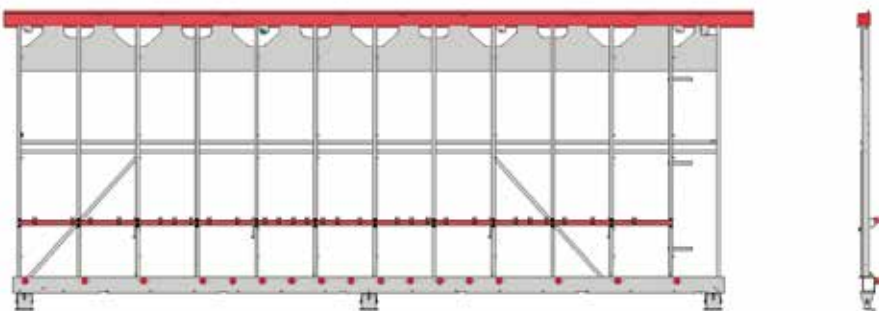

■ Comprehensive sizing frame, wide cutting range

COMPACT covers a cutting range from 3100 x 1644 mm (model 4164) to 5350 x 2200 mm (model 6220).

Entry into quality and precision – 2 versions for all wishes

COMPACT or COMPACT AV - whether you saw manually or with automatic feed - it's your choice.

The COMPACT series is characterised by a flexible and economical use. It is the entry-level class into the world of precision and quality of Striebig vertical panel saws.

Especially in this aspect an honest comparison is important. A number of equipment details that are included in the basic equipment of the COMPACT must elsewhere be retrofitted as additional equipment. Here, the following features should be mentioned

- integrated TRK extraction system to comply with the specifications of BG-Holz (German wood and timber insurance and safety association)
- strong powerful saw motor
- central and small workpiece support over the entire length of the machine
- Special longitudinal stop with integrated small-workpiece stop
- integrated workpiece locking system
- energy chain at the rear with integrated chip hose
- optimised dust collection in the saw casing



Universally used – (almost) unlimited diversity – with every Striebig COMPACT, you can saw an abundance of panel materials, and you get precise and sharp-edged results. All COMPACT versions are also ideally suited for cutting and grooving work.

■ COMPACT – entry-level class with comprehensive sizing frame

The COMPACT combines exemplary ergonomics with a high degree of functionality to form a harmonious entity with a high-quality look. Its sizing frame satisfies all the requirements of trade and industry.



COMPACT AV 6220 (fig. includes optional features)



COMPACT

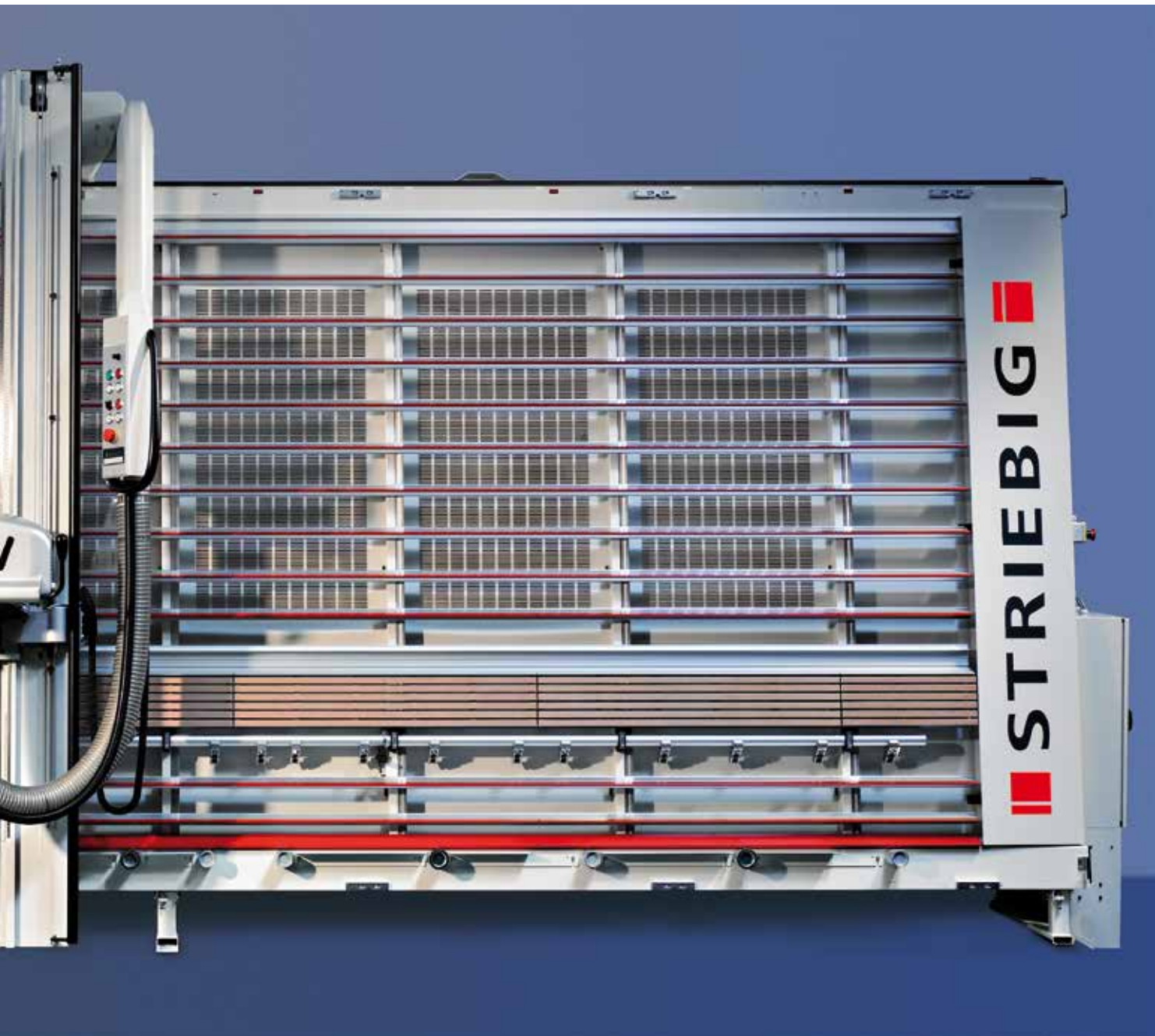

Function and benefit in every detail



Saw unit with powerful motor (3.9 kW) and length-adjustable operating lever, which significantly facilitates plunging.

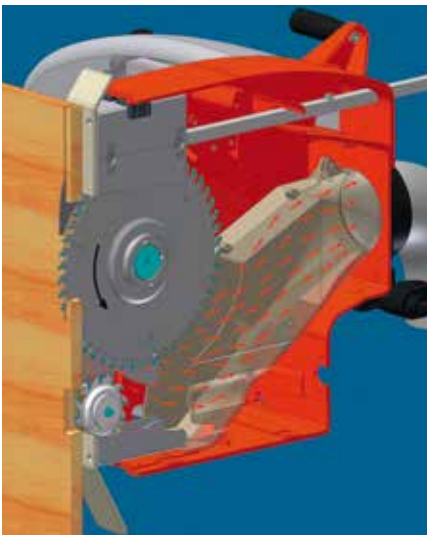

The integral TRK extraction system enables us to achieve dust limit values considerably below 1 mg/m^3 . We are therefore more than 50% below the applicable recommended values. The majority of the accumulating chips is already extracted via the saw unit thanks to an optimised air flow and a small casing. Dust accumulating with horizontal cuts is extracted via the outer right saw frame.



COMPACT av – pneumatically braked support rollers as standard equipment.
COMPACT – mechanically braked support rollers as optional equipment.



A clear and clean solution: the cable chain separates hose guide from power cable and will also accommodate larger quantities of cable quite easily. There is very little stress on the parts. This detail adds to the particular durability.



The plunge device (mechanical trip hook, operational also with the installation of a cutting height limiter) supports the safe plunging operation of the saw unit in the overhead area.

Automatic, economical, efficient – COMPACT AV at a glance

Sawing with automatic feed, no exhausting shifting of the saw unit, easier work for the operator - the COMPACT AV can offer all these benefits.



■ Automatic feed

A separate motor ensures the automatic feed in horizontal and vertical direction. 4 feed speeds (10/14/18/25 m/min) are available. The feed speed can be freely selected by means of a rotary switch. No effort must be made by the operator for the forward feed.

■ Sawing at the press of a button

In the automatic mode, the saw unit of the COMPACT AV automatically plunges into the material, cuts the panel horizontally or vertically and retracts automatically after the cutting operation. The saw stops at the end of the panel. A selectable automatic return (25 m/min) brings the saw back to its original position.

■ Economic sawing

The operator is not required to do physically exhausting work. Therefore the operator can fully concentrate on cutting, dimensioning and unloading the panels. The sawing sequence is performed automatically and very evenly with highest precision. Considerable time savings are achieved.

■ High operating convenience

Comfortable and efficient saw operation by means of the control unit.

The control unit of COMPACT AV has been ergonomically arranged at eye level. Due to its clearly arranged display, the saw can be operated efficiently and centrally.

Original Striebig accessories: individual extension of po

COMPACT and COMPACT AV come comprehensively equipped ex works. Due to a wide range of accessories offered, you can further extend convenience and performance of your COMPACT and fully adjust the machine to your individual needs.

	COMPACT	COMPACT AV
● optional S Standard		
Automatic sawing sequence	—	S
Scoring saw unit VSA	●	●
Digital measuring system DMS	●	●
Angle cutting unit WSG	●	●
Strip cutting gauge 400 mm / 600 mm	●	●
Central and small parts support over the entire length	S	S
Additional workpiece locking system	●	●
Aluminium small parts support (1 pair)	●	●
Paper holder	●	●
Central support: aluminium frames	S	S
Central support: high-end frames made of synthetic materials	●	●
Grooving accessory for composite panels	●	●
Profile cutter with reversible carbide tips: U-shaped, 135°, 90°	●	●
Depth stop for adjustable grooving tool	●	●
Adjustable grooving tool with reversible carbide tips	●	●
Mechanically braked support rollers	●	—
Pneumatically braked support rollers	—	S
Extension of the feed speed (25 m/min)	—	●
Special voltage	●	●
Tropical insulation	●	●



The angle cutting unit WSG maintains the set dimension accurately in all angle settings.



Continuous central and small parts support over the entire length for increased comfort while cutting small parts. Series: central support made of resistant aluminium grids. Option: high-end grids made of synthetic materials for especially demanding panel coatings.



Scoring saw unit VSA with infinitely adjustable saw blade. It safely prevents damage to the edges. It saves time, money and tool costs. If coated panels of a possibly lower quality level are processed, in our opinion, VSA is a "must"!



Strip cutting gauge, 400 and 600 mm in length with edge-protecting roller support.



Paper holder – documents always within reach at the control unit



COMPACT AV – pneumatically braked support rollers as standard equipment.
COMPACT – mechanically braked support rollers as optional equipment.

performance and convenience



Digital measuring system DMS – for measurements that are accurate to 1/10 mm.



Depth stop for adjustable grooving tools



Grooving device for composite boards

Composite panels – individual cutting, shaping and designing

Composite panels are a modern material for modern architecture, transportation, trade fair construction and shopfitting as well as for displays and many other applications. They can be processed without any problems on every Striebig COMPACT AV and COMPACT.

The groove bending technique allows an easy manufacture of formed parts. Reversible carbide tipped profile cutters cut V- and U-shaped grooves into the rear side of the panels. During this procedure, the aluminium cover on the front side and a part of the plastic core remain intact. The low thickness of the remaining material allows bending "by hand" afterwards. The groove shape determines the bending radius.

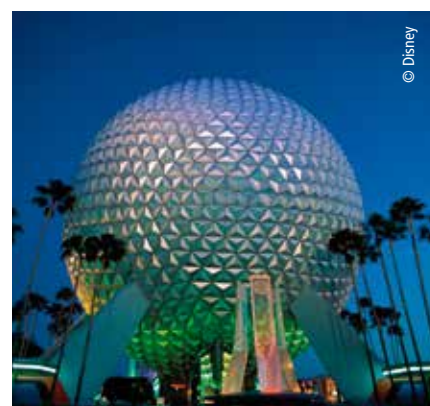

Composite panels are used as all-purpose material in architecture and facade engineering. They provide accents and offer manifold decorative possibilities.

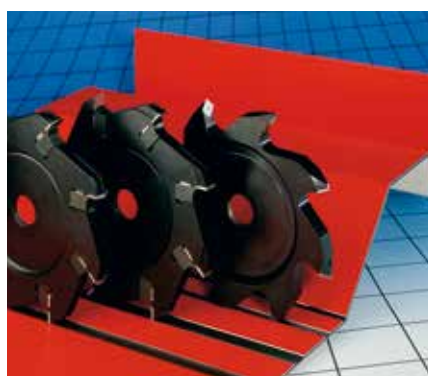

Available as accessories: Reversible carbide tipped profile cutters enable product-specific cutting of composite panels.

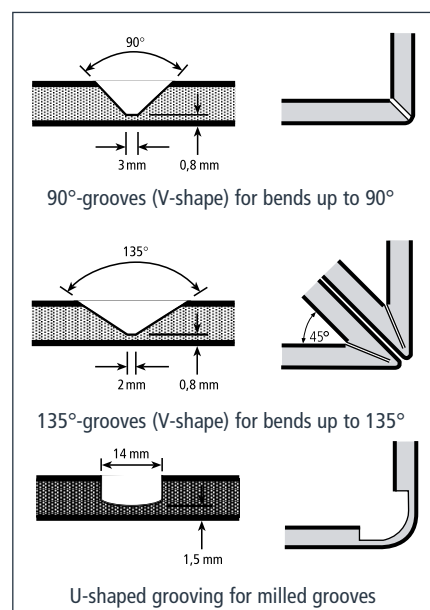

Impressive: COMPACT data and dimensions



CONTROL



EVOLUTION



STANDARD



COMPACT

For us, comprehensive equipment is a matter of course. A number of equipment details that are standard for us you can rarely find elsewhere even at additional cost. Compare for yourself.

- Exceptionally efficient integrated TRK dust extraction system.** Dust limit value below 1 mg/m³.
- Roller support with up to 17 rollers
- Automatically yielding support frame
- High-quality saw blade
- Adjustable penetration, 9 to 13 mm
- Powerful 3.9 kW motor
- Wooden small workpiece support over entire length
- Central support with aluminium frames over entire length
- Longitudinal stop with integrated small workpiece stop
- Length-adjustable operating lever
- Mirror on saw beam
- Safe packaging
- CE tested
- Detailed documentation
- Swiss Made

COMPACT							
Type	Dimensions in mm				Cutting range in mm		
	L	H	D1*	D2*	L	Hvert	Hhor
6220	6,506	2,980	1,466	1,441	5,350	2,200	2,100
6207	6,506	2,838	1,428	1,428	5,350	2,070	1,958
6164	6,506	2,400	1,391	1,391	5,350	1,644	1,532
5220	5,756	2,980	1,466	1,441	4,600	2,200	2,100
5207	5,756	2,838	1,428	1,428	4,600	2,070	1,958
5164	5,756	2,400	1,391	1,391	4,600	1,644	1,532
4220	4,256	2,980	1,466	1,441	3,100	2,200	2,100
4207	4,256	2,838	1,428	1,428	3,100	2,070	1,958
4164	4,256	2,400	1,391	1,391	3,100	1,644	1,532

COMPACT AV							
Type	Dimensions in mm				Cutting range in mm		
	L	H	D1*	D2*	H	Hvert	Hhor
6220	6,864	2,980	1,486	1,461	5,350	2,200	2,100
6207	6,864	2,838	1,448	1,448	5,350	2,070	1,958
6164	6,864	2,400	1,411	1,411	5,350	1,644	1,532
5220	6,114	2,980	1,486	1,461	4,600	2,200	2,100
5207	6,114	2,838	1,448	1,448	4,600	2,070	1,958
5164	6,114	2,400	1,411	1,411	4,600	1,644	1,532
4220	4,614	2,980	1,486	1,461	3,100	2,200	2,100
4207	4,614	2,838	1,448	1,448	3,100	2,070	1,958
4164	4,614	2,400	1,411	1,411	3,100	1,644	1,532

	COMPACT	COMPACT AV
Weight of the saw	approx. 815 kg	approx. 910 kg
Cutting depth	60 mm	60 mm
Saw motor rating	3,9 kW	3,9 kW
Saw blade diameter	250 mm	250 mm
Saw blade bore	30 mm* ¹	30 mm* ¹
Saw blade speed	5250 rpm	5250 rpm
2 extraction connections	ø 100 mm* ²	100 mm* ²
Wattage	4.8 kW	4.8 kW
Mains connection	3 x 400 V / 50 Hz	3 x 400 V / 50 Hz
Compressed air connection		6-8 bar
Emission sound pressure level at the workplace L _{pA}	82 dB* ³	
Special voltages and special frequencies on request		

D1* for free-standing installation (= option) · D2* for wall-mounted assembly (basic version) · *1 with 2 side holes Ø 7 mm, radius 21 mm
 *2 main extraction on the left or right, extraction wall on the right (fixed) · *3 Measurement standards and emission values in accordance with EN 1870-14, measurement uncertainty allowance K = 4 dB(A)

(All details refer to the COMPACT type 6220)

**TRK TRK is the abbreviation for „Technische Richt-Konzentration“ (technical target concentration). These values have been applicable since July 1988 and specify the maximum permissible wood dust concentration at the workplace. The TRK value is 2 mg/m³ total dust based on a working average (shift) of 8 hours. Connection to an external dust extraction system is required. The system used must have an extraction performance of 20 m/sec. (vacuum approx. 2,000 Pa.) at the connector in order to meet the TRK specifications.



The SWISS LABEL emphasises the origin and quality awareness of goods and services of Swiss origin. STRIEBIG AG is entitled to the use of this trademark.

Consultation · Sales · Service

Please refer to our website for the most current technical specifications of the COMPACT. Scan the QR code. Done!



Striebig AG
 Grossmatte 26
 CH-6014 Luzern
 Tel. 0041(0)41 259 53 53
 Fax 0041(0)41 259 53 50
 www.striebig.com
 info@striebig.ch

