

*As of now with BOOMERANG®  
return systems, starting on page 38*

# Edge banding machines

## Highflex 1220 - 1880

## KDN/F 1630 - KDN/F 1895 profiLine



# HOMAG Group

## Success through partnership

**To survive in a fiercely competitive market, a company has to have fast, flexible and efficient production.**

**The HOMAG Group, with its sales and service network in over 90 countries around the world, offers you and your employees a strong partnership no matter where you are.**

The HOMAG Group of companies cover all areas of woodworking and wood-processing.

Panel sizing, sawing, edge technology, transportation technology and handling systems are just a few of our specialties. We also offer solutions for drilling, coating technology, surface technology, plants for doors and doorframes, timber house

construction, sanding technology, automation systems, packaging equipment and software. We provide a complete and innovative range of products and services that are always the perfect solution for any requirement.

You, our customers, benefit from high precision, performance and cutting-edge technology.



# BRANDT

## Perfect edges for demanding customers

**We offer our customers innovative and powerful edge banding machines. Efficiency and quality have the highest priority, and ensure long-term competitive advantages for you. With an annual production of over 2000 edge banding machines, we are the edge banding specialist in the HOMAG Group and the world leader in our market segment.**

A high degree of standardization in combination with an advanced manufacturing process and more than 50 years of engineering experience ensure state of the art quality at a superb price-performance ratio. Our clear and structured product range is designed to meet the demands of current and future market trends.

All of our developments are focused toward practically-oriented and economic solutions that guarantee you the best possible production results.



**"With us, you and your products come first. A promise that you can count on!"**

# Highflex & profiLine series

## Precision and performance for the most demanding jobs

**The Highflex series is characterized by its high degree of automation and well equipped units. This high level of flexibility allows perfect focus on your needs and guarantees perfect edges.**

Because of its modular design and the freely-fittable frame concept, it is possible to configure perfectly tailor-made machines according to specific requirements.

The characteristics of all BRANDT machines are combined in these two series to make them perfectly-equipped for any job



## The right solution for your requirements

The Highflex & **profiLine** series machine leaves nothing lacking. Whether your needs are "batch size one" production, for demanding bespoke shop fitting applications, living & bedroom furniture or functional office furniture, the Highflex & **profiLine** Series always offers the right solution for your requirements.



Highflex 1650



# Optimal preparation for a perfect result. Highflex 1220 + 1230



## Contact heating shoe

As standard, all machines of the 1200 series are equipped with a contact heating shoe that – optionally activated – transfers contact heat into the board edge directly prior to the glue application to the workpiece edge, this notably optimising the gluing quality, especially with difficult edging materials or at very low ambient temperatures.

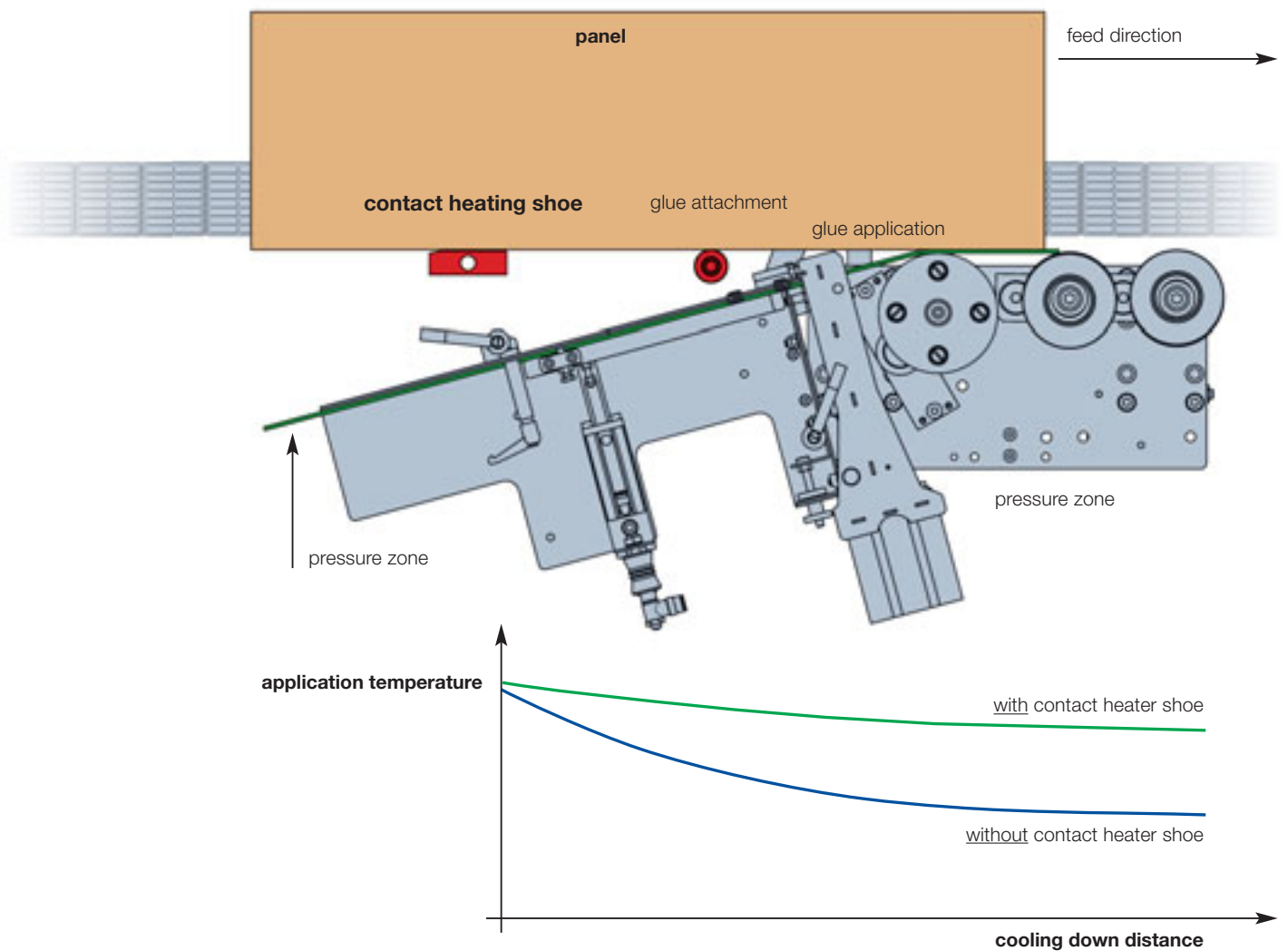

# easyTouch – Gentle touch – big results

The easyTouch control system represents a new generation of control systems.

A simple touch guarantees quick navigation combined with a high degree of operator comfort.

- A clear 7" graphic display for optimal control by directly touching the control panel.
- 20 storable programs provide the necessary flexibility for a wide variety of edge materials and ever-changing customers' demands.
- Machine operation status by means of onscreen display.
- Easy workstation access by control keys.
- Intuitive, user oriented navigation.
- Clearly readable presentation of all assisting functions, such as glue temperature, or error diagnosis.

Betriebsdatenerfassung		1. 2mm ABS
Stunden Gesamt	h	1:17:48.00
Werkstücke Gesamt	Stk	40000
Kantenlänge Gesamt	m	3000.1
Stunden	h	0:45.00
Werkstücke	Stk	200
Kantenlänge	m	150.00

Exact compilation of production data for each job.



# Significant competitive advantages – Pace setting performance and quality. Highflex 1220 + 1230

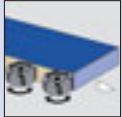

## Joint trimming unit

Perfect cut and high operating life due to diamond tipped tools for an optimum edge joint quality.

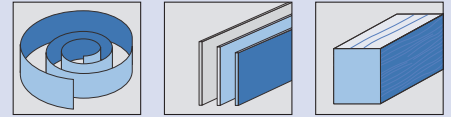
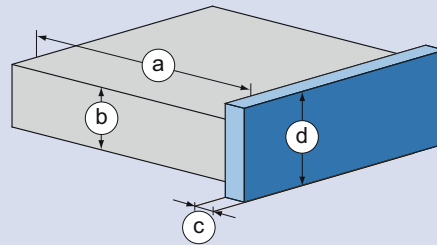

mm	Coil	Strips	Solid
a		min. 70	
b		8 - 60	
c		0,4 - 6	
d		65	



## Counter pressure device

Counter pressure device magazine for sensitive edges.

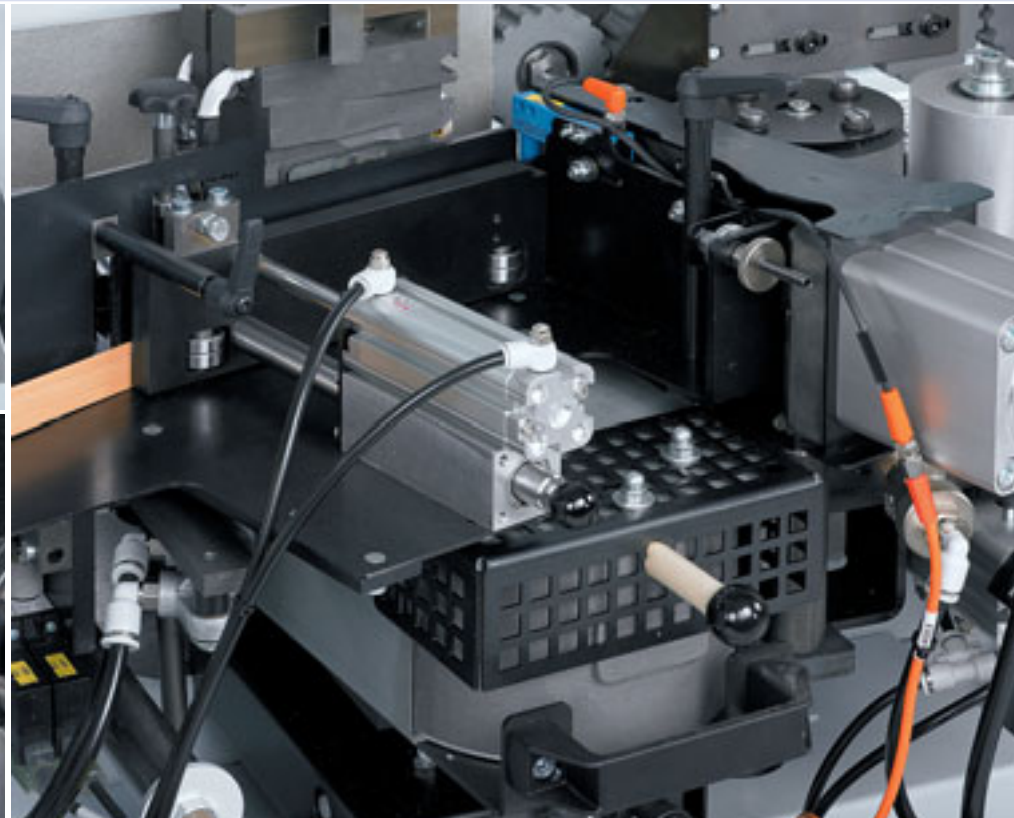

## Gluing unit and magazine

Coil and automatic strip magazine for a reliable edge material supply. Optimal glue joints, by controlling the exact amount of glue.





**Spraying unit (optional)**

Separation and detergent agents for a perfect finish when processing PU-glue.



**Automatic edge infeed device (optional)**

Automatic edge infeed device for fast change over between different coiled materials.



**Pressure zone**

Heavy pressure zone up to 6 mm edge thickness and 60 mm workpiece height for an optimal glue joint.

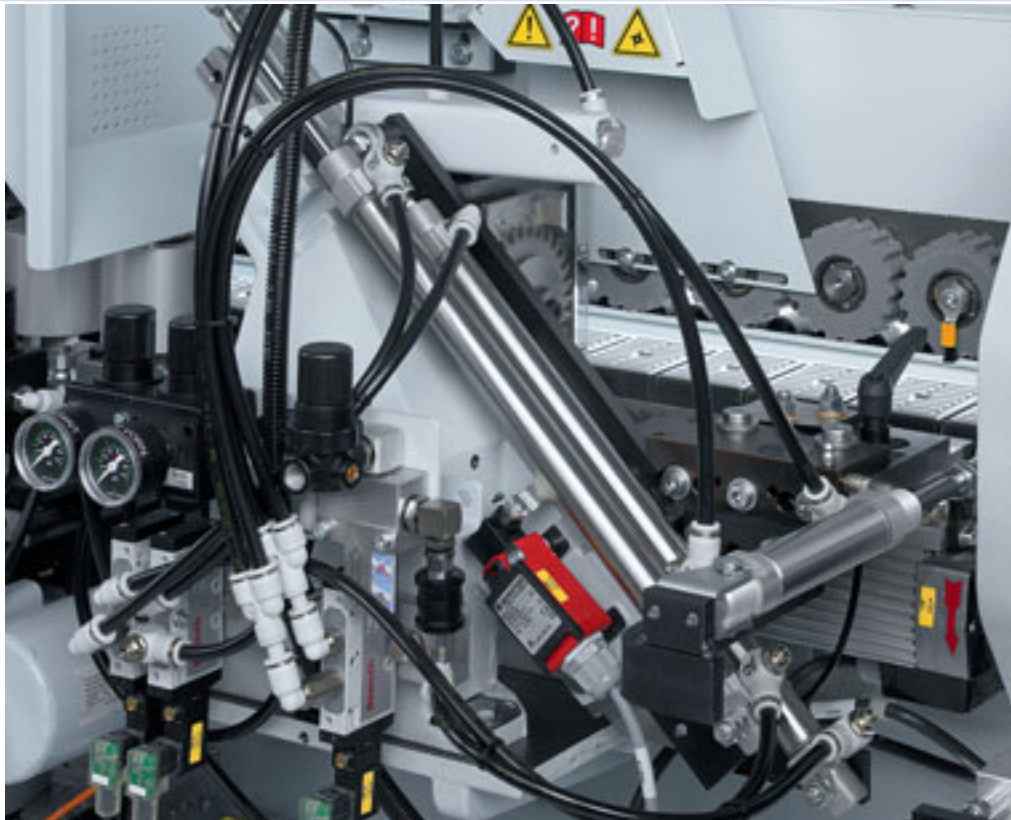
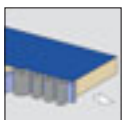

**End-trimming unit**

Precise end-cut through a strong end-trimming unit, equipped with THK guides. Chamfer/straight adjustment by easily tilting the unit. Pneumatic adjustment.

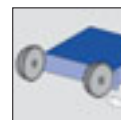

# Significant competitive advantages – Pace setting performance and quality. Highflex 1220 + 1230

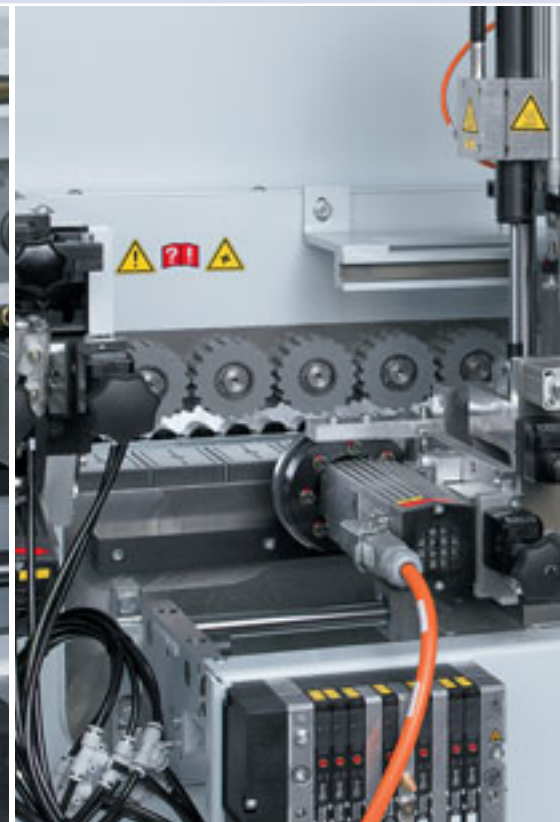
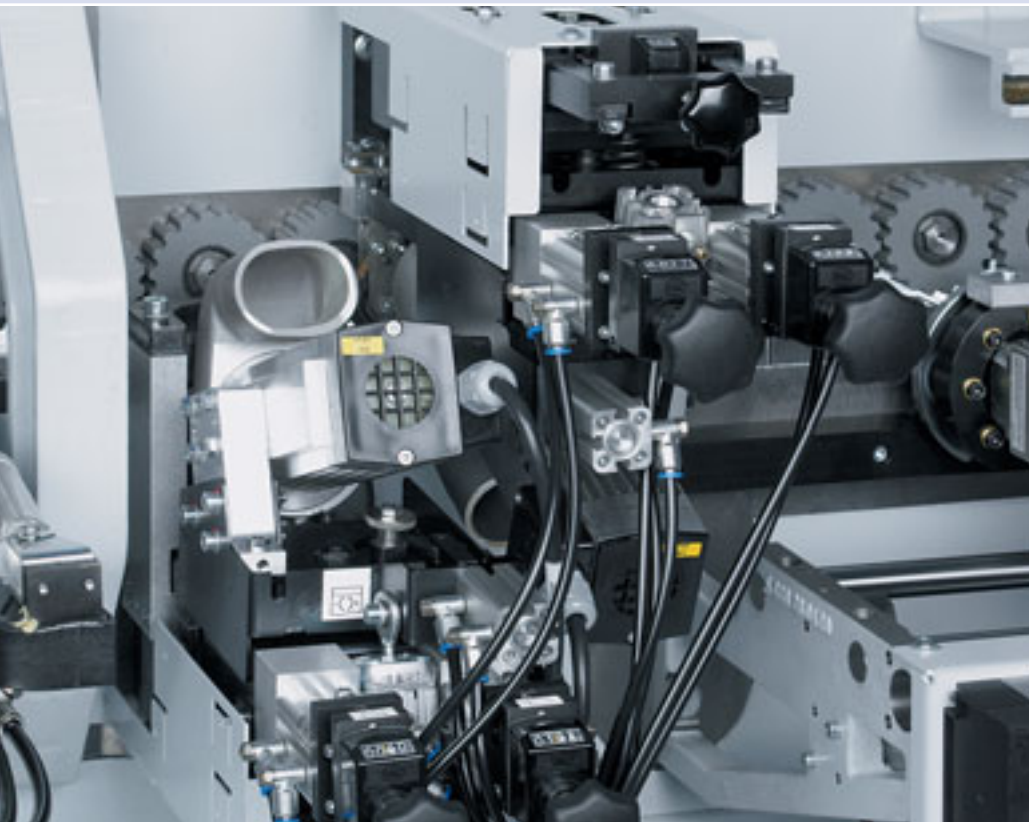

## Trimming unit with pneumatic 3-point adjustment

For even more effective production and  
much shorter changeover time.

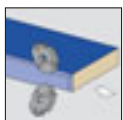

## Corner rounding unit FF 10

Optimum corner rounding without adjust-  
ment or set-up, resulting from the coupled  
diamond tool and tracer roller. Workpiece  
thickness up to 40 mm. Workpiece thick-  
ness 60 mm - Highflex 1230.





**Central lubrication unit**

To lubricate the feed track guidance system to guarantee precision and a long life of the conveyor chain.

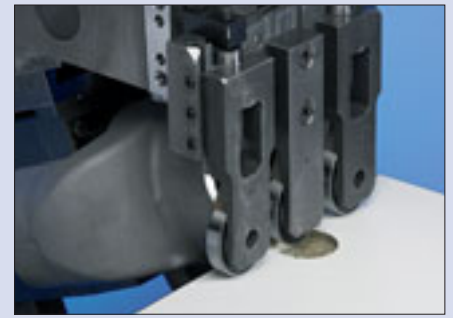

**Nesting package (optional)**

Includes a multi-roller tracing device for the trimming and scraping units to compensate for hinge holes.

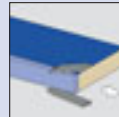

**Glue joint scraping unit (optional Highflex 1220)**

For the perfect finish.

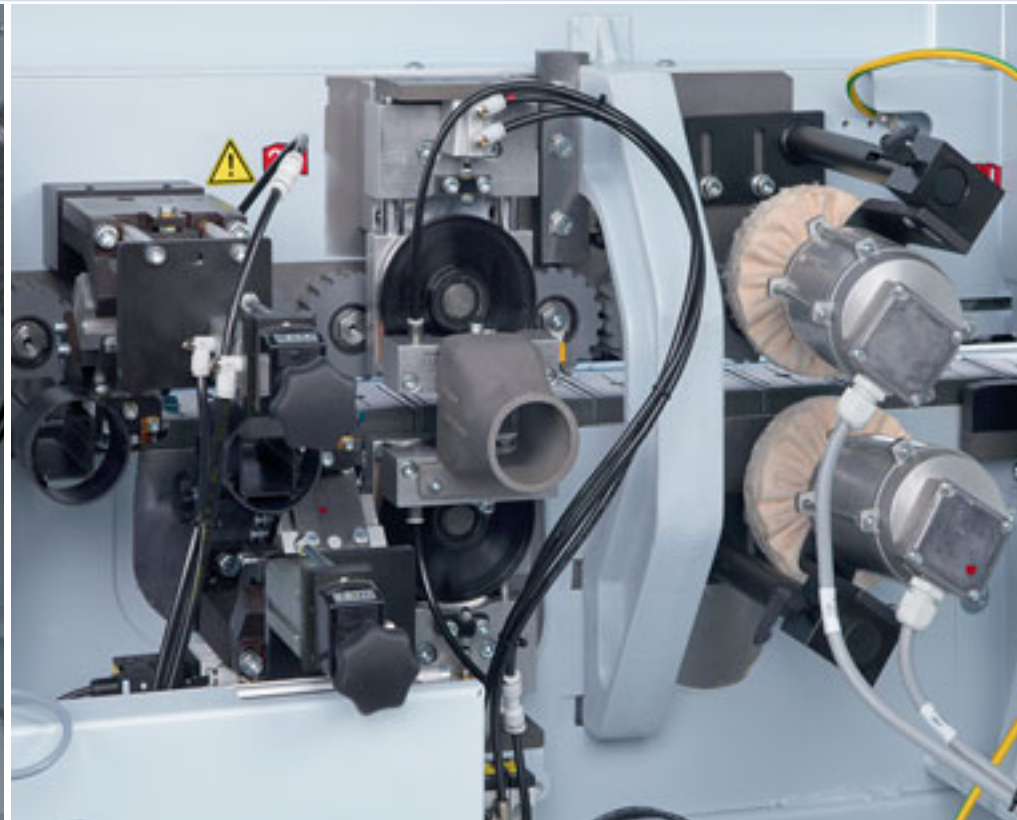

**Profile scraping unit**

To smooth radii or chamfers (Pneumatic adjustment optional).

**Buffing unit**

Buffing unit to polish edges and maintain their natural colour.

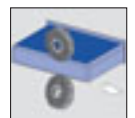
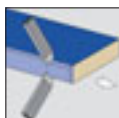

# powerTouch – The new dimension in machine operation

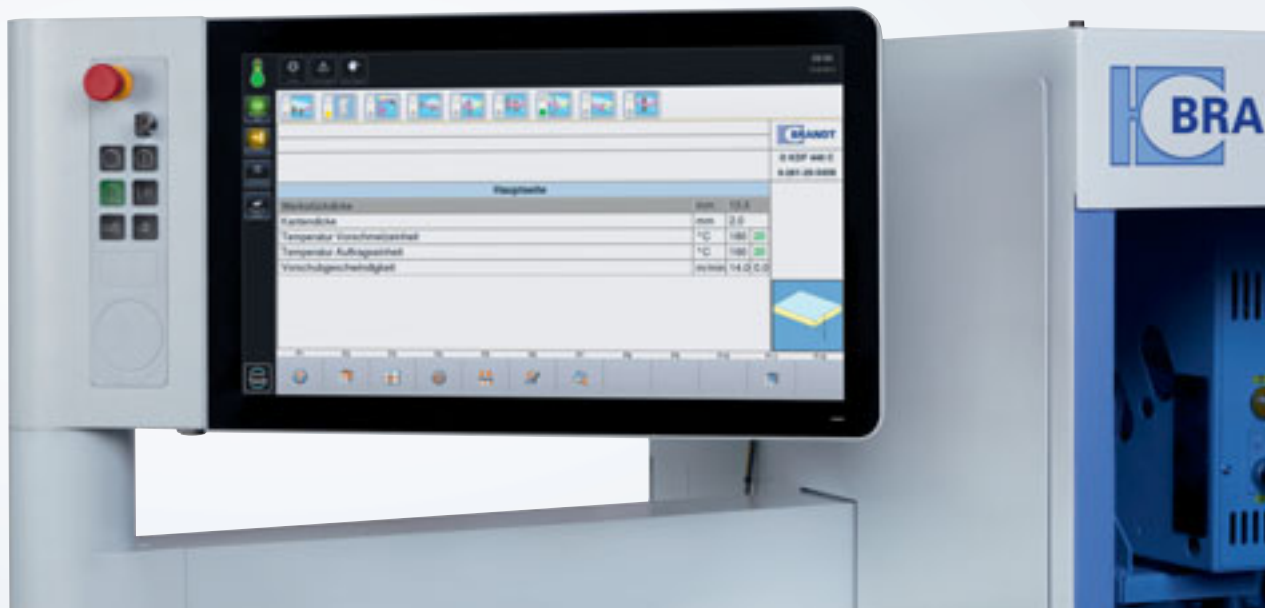

powerTouch implements the HOMAG Group's new operating philosophy:

**Simple, standardized, ergonomic and evolutionary. The innovative touchscreen operating concept unites design and function to create a totally new control generation.**

- 21" screen with full HD resolution
- Fast overview of machine status
- Simple, user-oriented navigation
- Traffic light assistant helps guide the user towards readiness for production
- Standardized design of the user interface
- Intuitive, natural touch operation of the machine
- Use of gestures such as swiping, scrolling

"At the focus of this solution is a large multi-touch monitor in widescreen format, which is used to control machine functions by direct touch contact. The entire user interface has been optimized for touch operation and offers an array of help and assistance functions designed to radically simplify the work experience. Standardized control elements and software modules ensure that all HOMAG

Group machines can be operated with the same familiar look and feel using this new concept. They differ only in terms of a few machine-specific details. This not only simplifies the operation of different machines, but also makes for great efficiency by significantly reducing time for servicing and training."



"Machine data capturing for maintenance depending on need and for the representation of important operating figures (e.g. number of pieces, production time, edge material quantity)"



### Teleservice reduces field service work operations

- Reduction of service cost
- Avoidance of an unscheduled machine downtime
- Specific scheduling of field service work + spare parts
- Support to maintenance and operation staff

# airTec - Reactivation unit

## Zero joint technology for highest demands

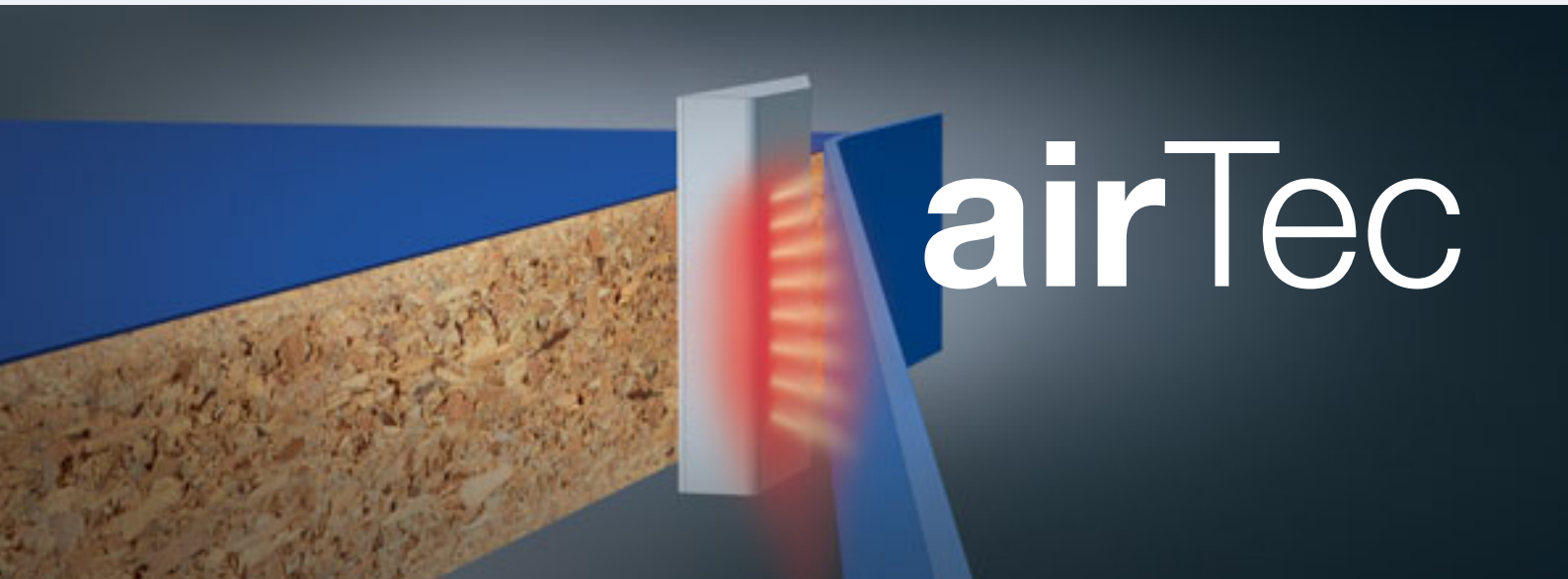

The **airTec – reactivation unit (optional)** guarantees optimal zero joints and is an industrial- and craft-oriented solution. To achieve a zero joint finish, the function layer on the edging material is reactivated by compressed hot air, providing seamless adhesion.



Unit for the activation of the functional layer on edge material, for a workpiece thickness from 8 - 40 mm. The **airTec** reactivation unit is installed in such a manner that you can work either with the standard glue application unit or with the airTec system. **airTec** can be used to process all types of currently popular, laser suitable edging types.

- Installation ex factory with complete integration into the control
- Temperature and pressure adjustable via control
- Process-specific parameters can be assigned to the corresponding programs and stored
- Indication of set and actual temperature
- The actual air consumption value depends on panel length and the gaps between the workpieces.



### Spraying unit - standard

The spray unit for Antistatic solvent is included in the **airTec – reactivation unit**, to achieve a perfect finish.

### Easy integration into the magazine

	Activation unit AT15	Activation unit AT20
Feed speed max.	15 m/min	20 m/min
Workpiece thickness	8 - 40 mm	
Operating pressure	4 - 6 bar	4 - 7 bar
Air consumption	250 - 1.400 N/min.	

\*The following requirements must be provided by the customer:  
 - Compressed air supply 8 bars - 1 inch supply line - 1500 NI/min.

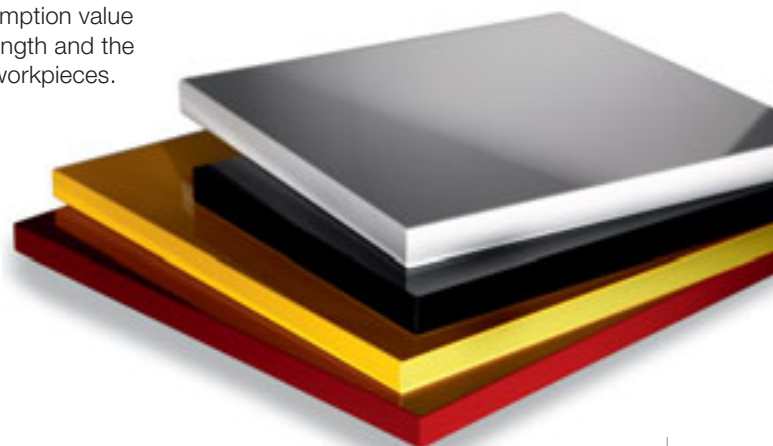

# Significant competitive advantages – Pace setting performance and quality. Highflex 1430 + 1440

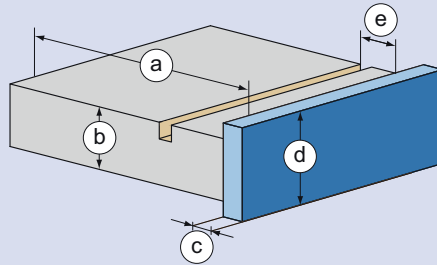

mm	Coil	Strips	Solid
a		min. 70	
b		8 - 60	
c		0,4 - 8	
d		65	
e		max. 30	



## Joint trimming unit

Perfect cut and high operating life due to diamond tipped tools for an optimum edge joint quality.

## Pre-melter

On-demand availability and perfect glue quality with Quickmelt.

## Gluing unit and magazine

Coil and automatic strip magazine for a reliable edge material supply. Optimal glue joints, by controlling the exact amount of glue.

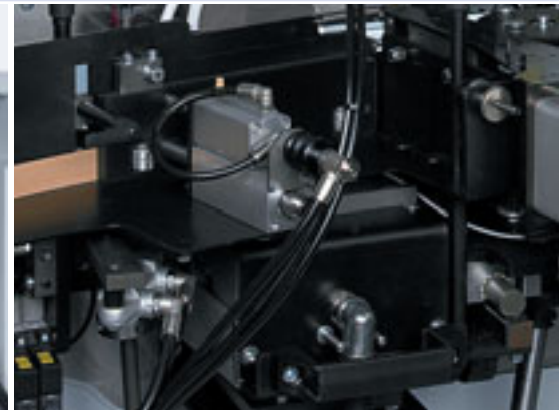

## Radiant heater

Strong adhesion through optimal pre-heating of the workpiece.

## Counter pressure device

Counter pressure device magazine for sensitive edges.

## Pressure zone

Heavy pressure zone up to 8 mm edge thickness and 60 mm workpiece height for an optimal glue joint.

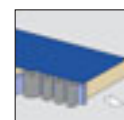



**Spraying unit (optional)**

Separation and detergent agents for a perfect finish when processing PU-glue.



**Infeed stop**

For minimum workpiece spacing and safe operation.



**Automatic edge infeed device (optional)**

Automatic edge infeed device for fast change over between different coiled materials.

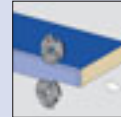

**Rough trimming unit**

For rough trimming of all common edge banding materials.



**End-trimming unit**

Precise end-cut through a strong end-trimming unit, equipped with THK guides. Chamfer/straight adjustment by easily tilting the unit. Pneumatic adjustment.

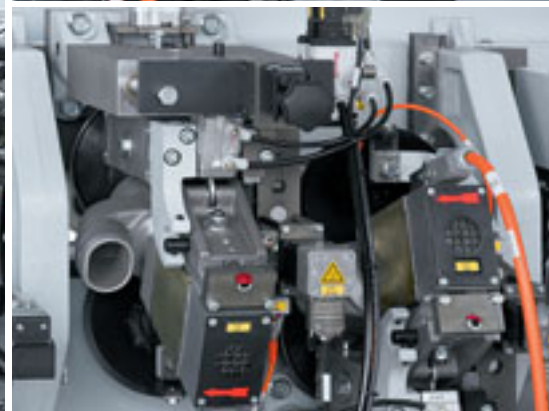
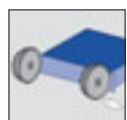

**Trimming unit**

Flexible adaptation to different edge thicknesses and profiles through servo axes.

**Multistage trimming unit MS 40/45 (optional)**

Fully automatic adjustment between 3 different profiles by means of servo motors.

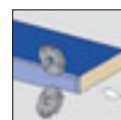

# Significant competitive advantages – Pace setting performance and quality. Highflex 1430 + 1440

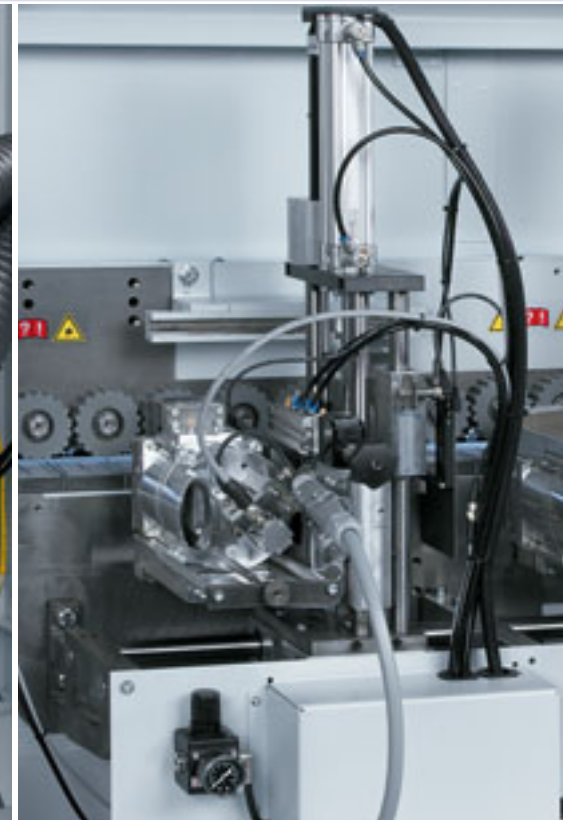
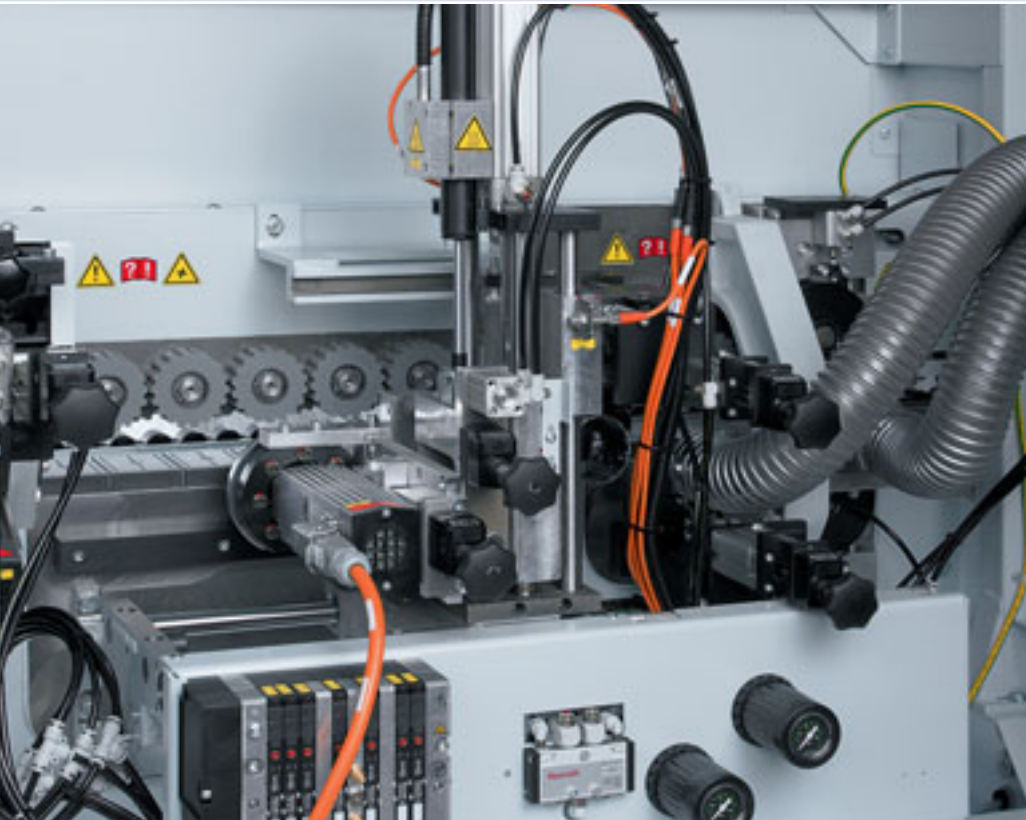

## Corner rounding unit FF 10 (Highflex 1430)

Optimum corner rounding without adjustment or set-up, resulting from the coupled DIA tool and tracer roller.  
Workpiece thickness up to 60 mm.



## Multifunctional trimming unit MF 50 (Highflex 1440)

Trimming of the edge overhang on top and bottom side as well as contour trimming on the front and rear edges. Equipped with an automatic adjustment to switch between thick and thin edges.

Workpiece thickness up to 60 mm.







**Pressure beam adjustment with servo motor**

Motor controlled guidance, to exactly match workpiece thickness.



**Central lubrication unit**

To lubricate the feed track guidance system to guarantee precision and a long life of the conveyor chain.



**Nesting package (optional)**

Includes a multi-roller tracing device for the trimming and scraping units to compensate for hinge holes.

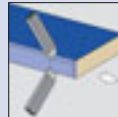

**Profile scraping unit**

Unit to smooth radii or chamfers, equipped with quick change heads for fast profile change.

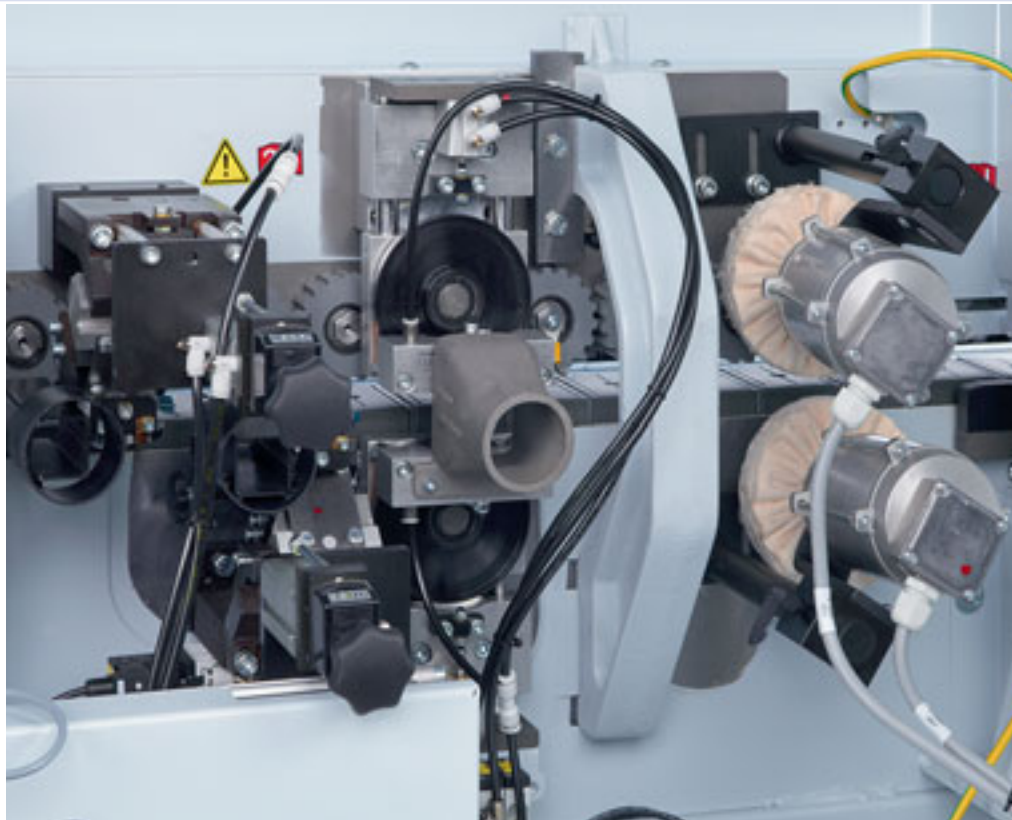

**Glue joint scraping unit**

For the perfect finish.

**Buffing unit**

Buffing unit to polish edges and maintain their natural colour.

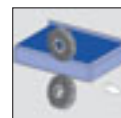
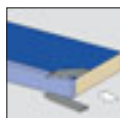

# Significant competitive advantages – Pace setting performance and quality. Highflex 1650 + 1660

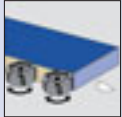

## Joint trimming unit

Perfect cut and high operating life due to diamond tipped tools for an optimum edge joint quality.

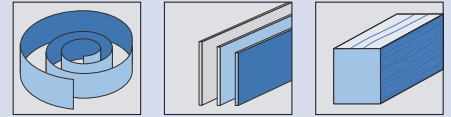
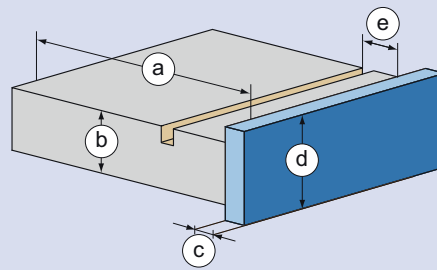

mm	Coil	Strips	Solid
a		min. 70	
b		8 - 60 (optional 80)	
c		0,4 - 15	
d		65 (optional 85)	
e		max. 30	



## Radiant heater

Strong adhesion through optimal pre heating of the workpiece.

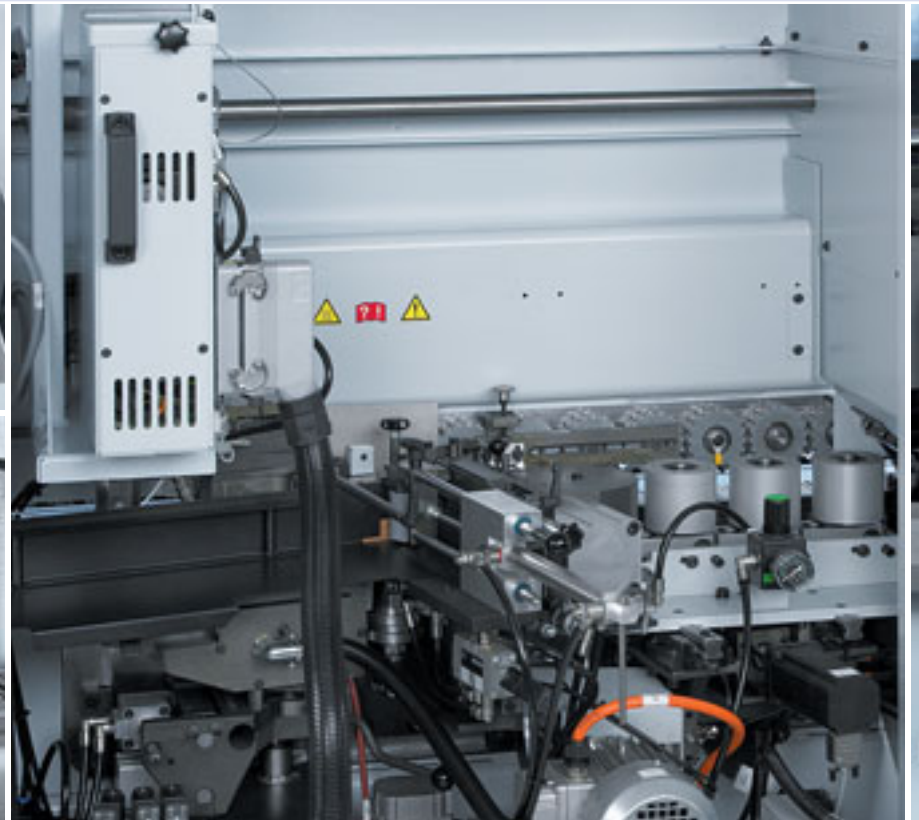

## Magazine + pre-melter (optional)

Coil and automatic strip magazine with optical monitoring for reliable material supply, high availability and perfect glue quality via the Quickmelt gluing unit.



**Automatic edge infeed device (optional)**

Automatic edge infeed device for fast change over between different coiled materials.



**Pressure zone**

Heavy pressure zone (up to 15 mm) to ensure an optimum glue joint quality.



**V-belt top pressure (optional)**

Top pressure V-belt system optionally available instead of the standard top pressure roller system.



**Rough trimming unit**

For rough trimming of all common edge banding materials.



**End trimming unit**

Perfect cutting by the end trimming unit using rigid high-precision linear guides and the workpiece gap optimization (optional) package to achieve higher output in the same processing time. Soft-touch for optimal end trimming results even at high speeds.

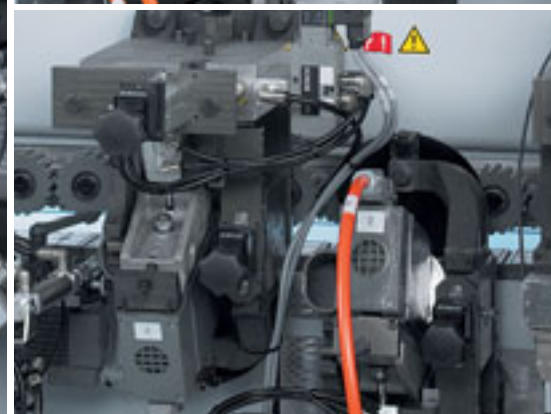
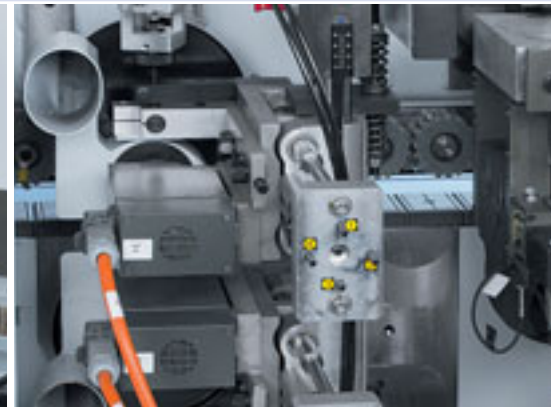
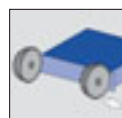

**Trimming unit**

Trimming unit with DFC (Dust Flow Control) tooling technology for optimal extraction. Optional pneumatic or servo axis adjustment available.

**Multistage trimming unit MS 40/45 (optional)**

Fully automatic adjustment between 3 different profiles by means of servo motors.



# Significant competitive advantages – Pace setting performance and quality. Highflex 1650 + 1660

## Multistage technology



1. Straight

2. Profile 1

3. Profile 2



### Multifunctional trimming unit MF 50

Trimming of the edge overhang on top and bottom side as well as contour trimming on the front and rear edges. Equipped with an automatic adjustment to switch between thick and thin edges. Workpiece thickness up to 60 mm.



### Multistage trimming unit MS 40/45 (optional)

Fully automatic adjustment between 3 different profiles by means of servo motors\*.

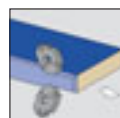

\***Servo motors:** The servo drive consists of a motor with an infinite adjustment. The result is high performance accuracy, especially in case of short adjusting distances.



**Spraying unit (optional)**

Separation and detergent agents for a perfect finish when processing PU-glue.



**Central lubrication unit**

Fully automatic lubrication of the feed track guidance system to guarantee precision and a long-life time of the conveyor chain.



**Nesting package (optional)**

Includes a multi-roller tracing device for the trimming and scraping units to compensate for hinge holes.



1. Profile 1



2. Profile 2

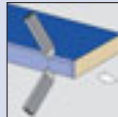

**Profile scraping unit**

Unit to smooth radii or chamfers, equipped with quick change heads for fast profile change.

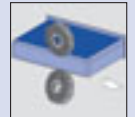

**Buffing unit**

Buffing unit to polish edges and maintain their natural colour.

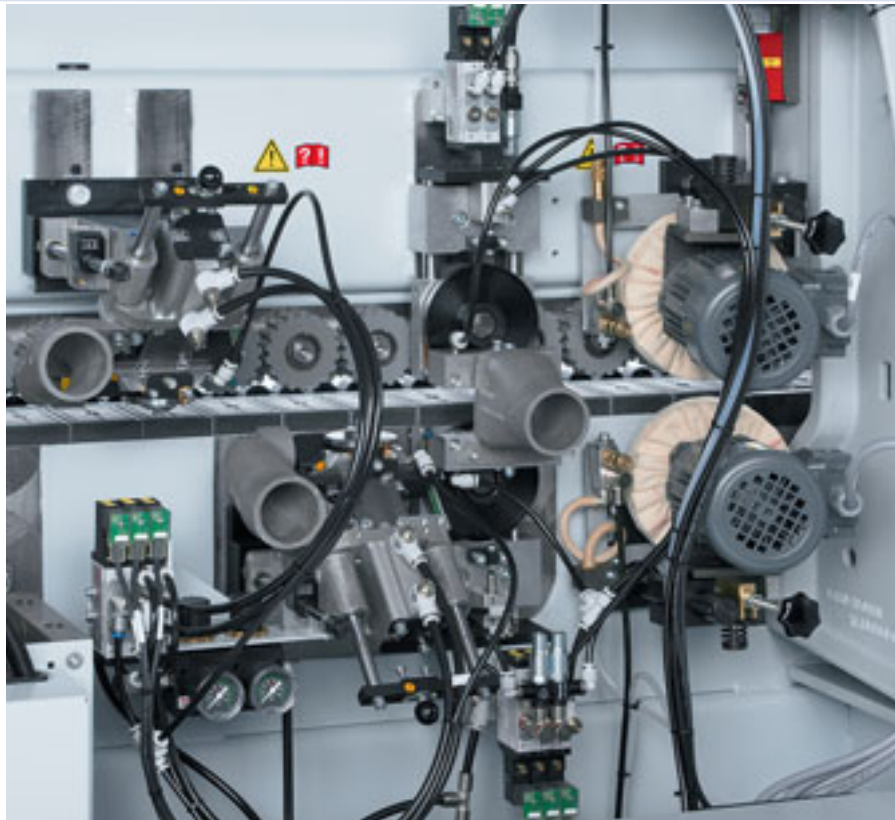
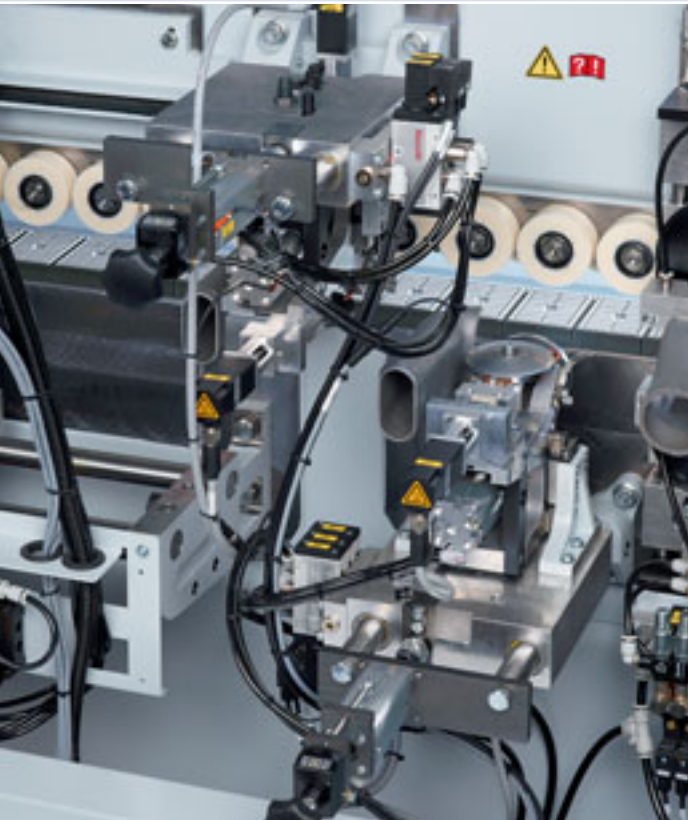

**Multistage scraping unit MZ 40 (optional)**

Fully automatic adjustment between 2 different profiles by means of servo motors\*.

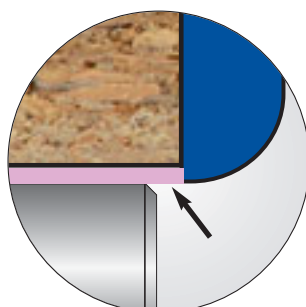
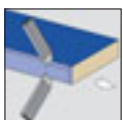

**Optimal positioning for protection foil / peelcoat materials.**

**Glue joint scraping unit**

For the perfect finish.

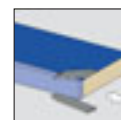

# Significant competitive advantages – Pace setting performance and quality. Highflex 1870 + 1880



## Joint trimming unit

Perfect cut and high operating life due to diamond tipped tools for an optimum edge joint quality.

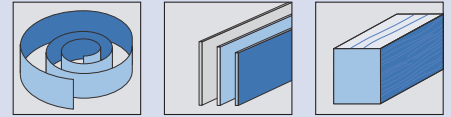
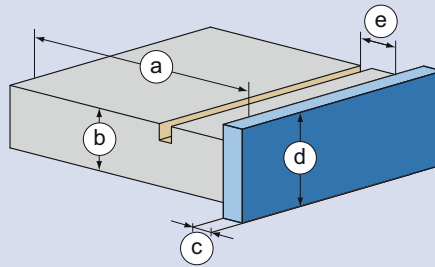

mm	Coil	Strips	Solid
a		min. 70	
b		8 -60 (optional 80)	
c		0,4 - 15 (optional 20)	
d		65 (optional 85)	
e		max. 30	



## Radiant heater

Strong adhesion through optimal pre heating of the workpiece.

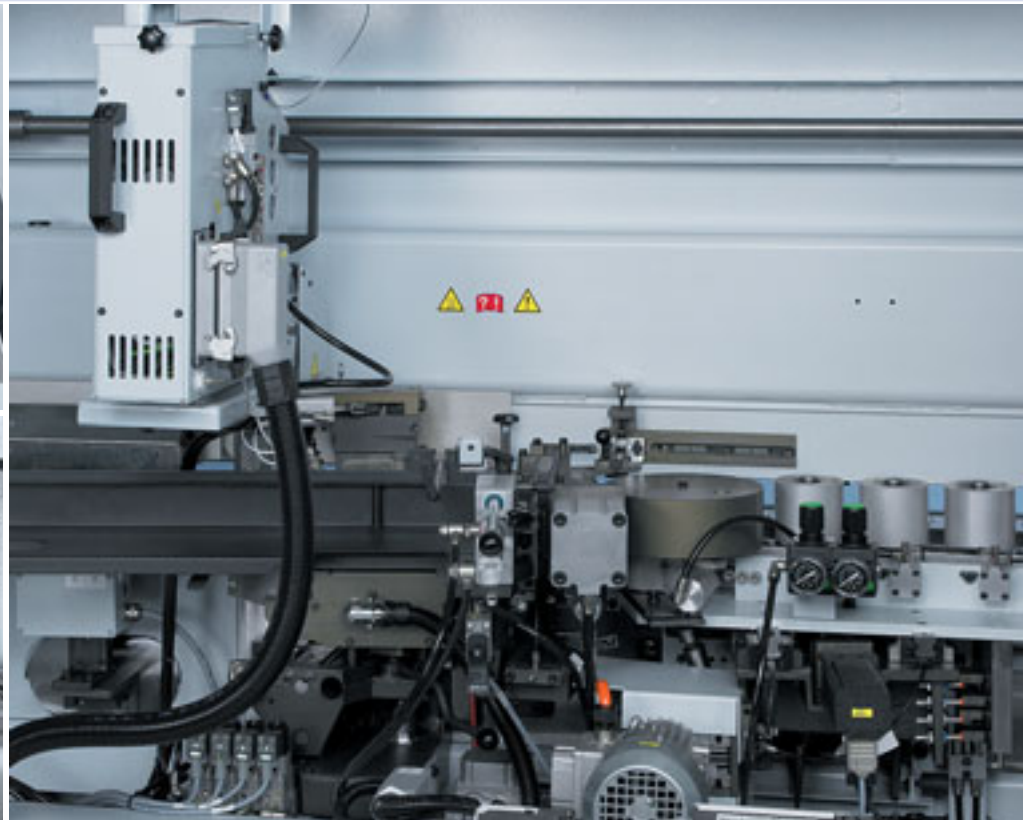

## Magazine + pre-melter (optional)

Coil and automatic strip magazine with optical monitoring for reliable material supply, high availability and perfect glue quality via the Quickmelt gluing unit.



**Infeed stop**

For minimum workpiece spacing and safe operation.



**Extra wide magazine (optional)**

Extra wide magazine with high capacity for fixed length strips and optimum access to reload.

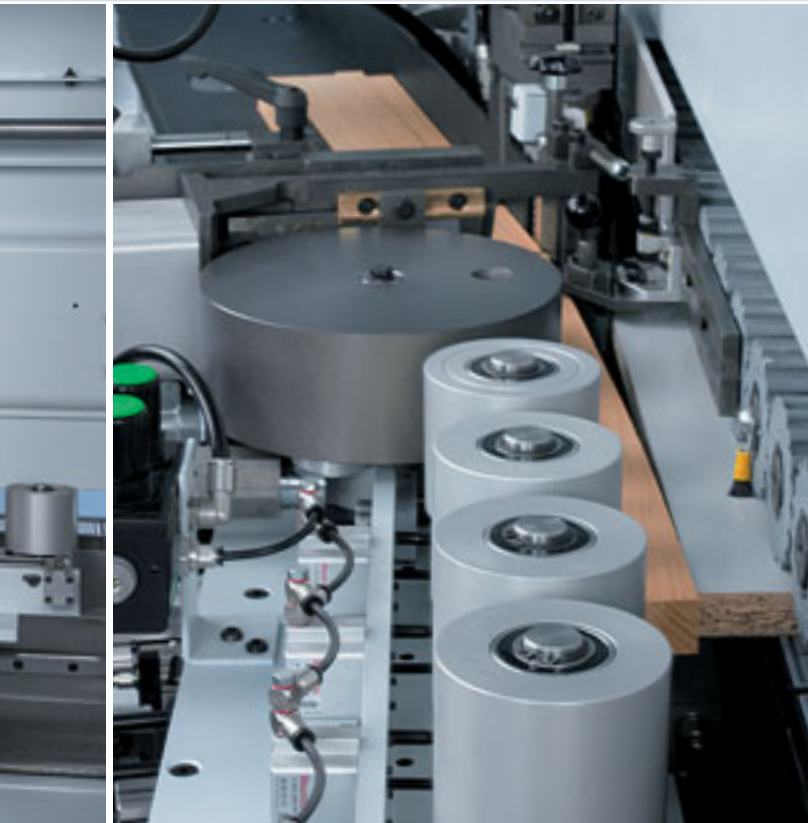

**Pressure zone**

Heavy pressure zone (up to 20 mm) to ensure an optimum glue joint quality.



**End trimming unit**

Perfect cutting by the end trimming unit using rigid high-precision linear guides and the workpiece gap optimization package to achieve higher output in the same processing time. Soft-touch for optimal end trimming results even at high speeds.

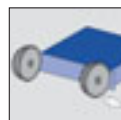
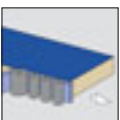

# Significant competitive advantages – Pace setting performance and quality. Highflex 1870 + 1880



## Rough trimming unit

For rough trimming of all common edge banding materials.

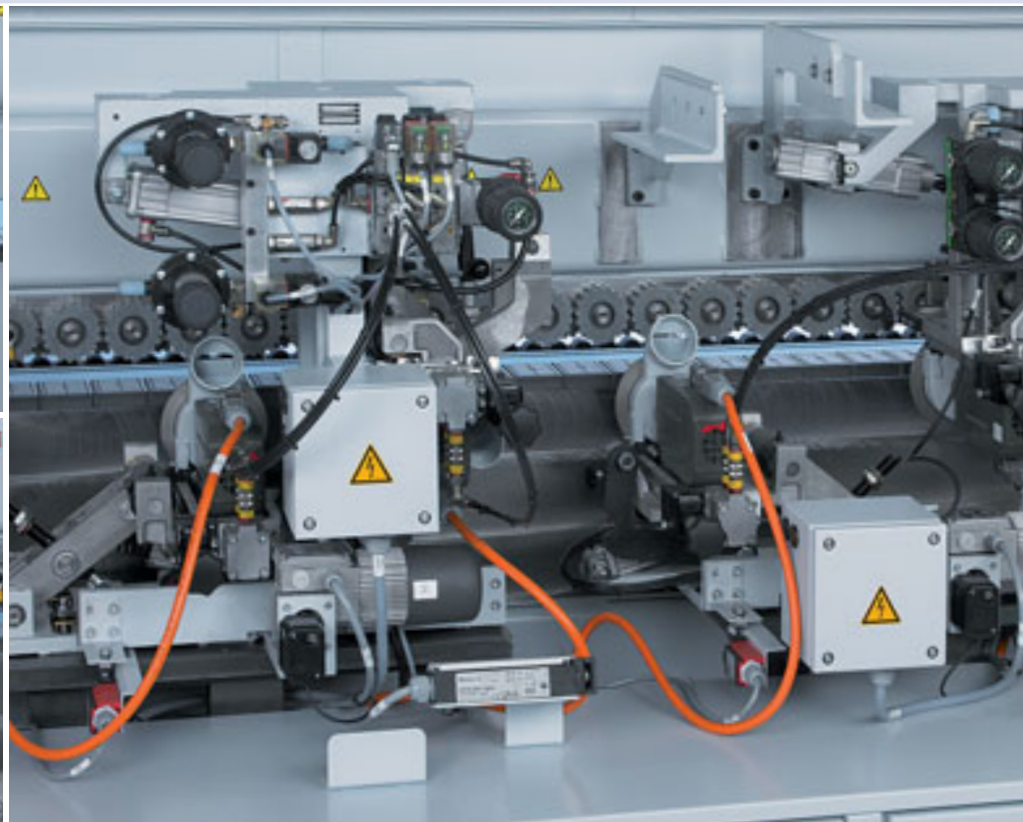
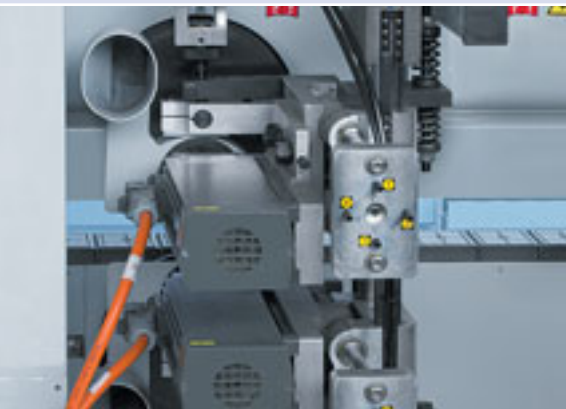

## Trimming unit

Trimming unit with DFC tool technology for optimum extraction. Equipped with servo axis to adjust the unit automatically to edge thickness and profile.

### Multistage trimming unit MS 40/45 (optional)

Fully automatic adjustment between 3 different profiles by means of servo motors.

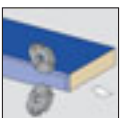

## Corner rounding unit FF12 (4 motors)

For corner rounding of thick PVC edges, as well as postforming and softforming profiles at feed speeds of up to 20 m/min. Equipped with servo motor adjustment for different edge thicknesses. Workpiece thickness up to 60 mm.







**Central lubrication unit**

Fully automatic lubrication of the feed track guidance system to guarantee precision and a long-life time of the conveyor chain.



**Nesting package (optional)**

Includes a multi-roller tracing device for the trimming and scraping units to compensate for hinge holes.



**V-belt top pressure (optional)**

Top pressure V-belt system optionally available instead of the standard top pressure roller system.

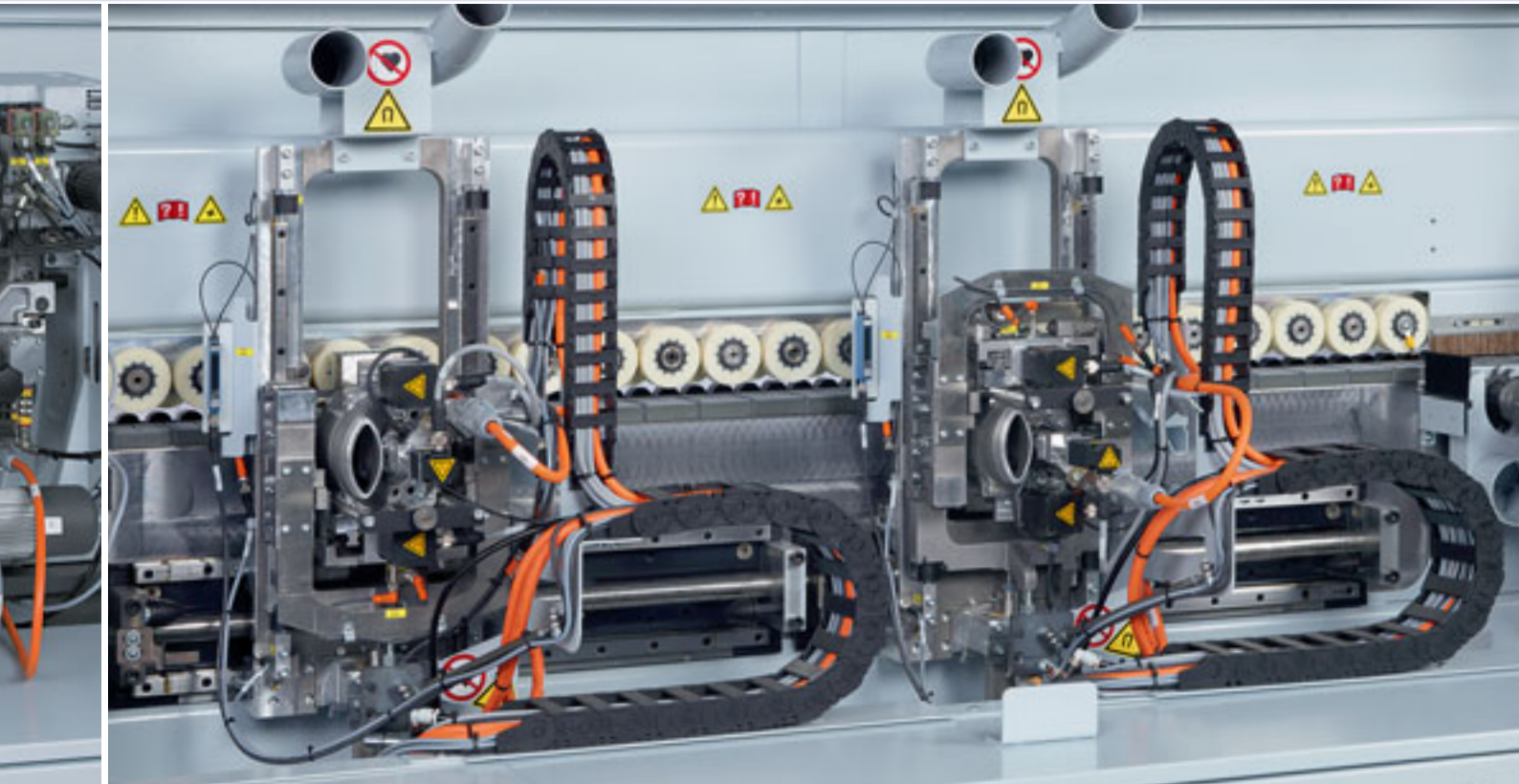

**Multifunctional trimming unit MF 60 Servotrim**

For processing the edging overhang at the upper and lower edge of the workpiece as well as for corner rounding of the front and rear edge. Servo-controlled movement with soft-touch function for optimal handling of e.g. high gloss surfaces or light weight panels. Workpiece thickness up to 100 mm.



# Multistage technology – flexible results for high demands

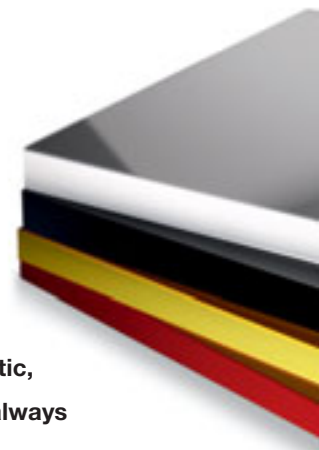

The spectrum of edge and panel material is growing continuously, which means that the requirements of our customers are increasing, too. No matter what materials you use: plastic, solid wood, veneers and high gloss surfaces. The multistage trimming and scraping units always offer the ideal radius and the best results.



1. Straight      2. Profile 1      3. Profile 2

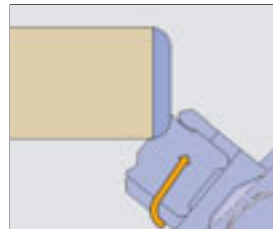

1. Profile 1

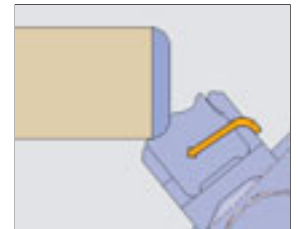

2. Profile 2

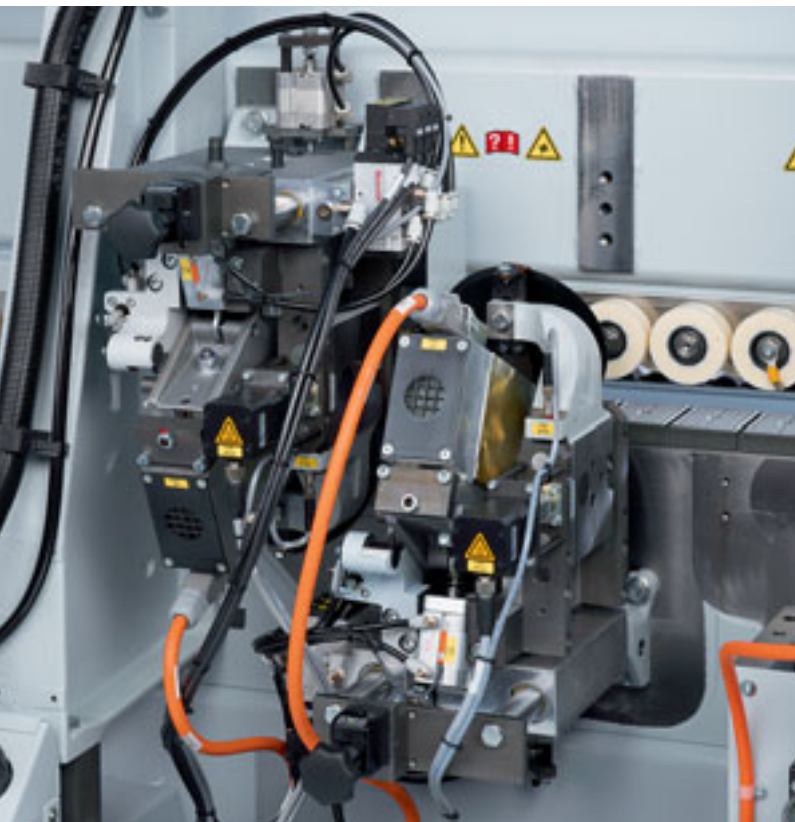

## Multistage trimming unit MS 40/45 (optional)

Fully automatic adjustment between 3 different profiles by means of servo motors\*.

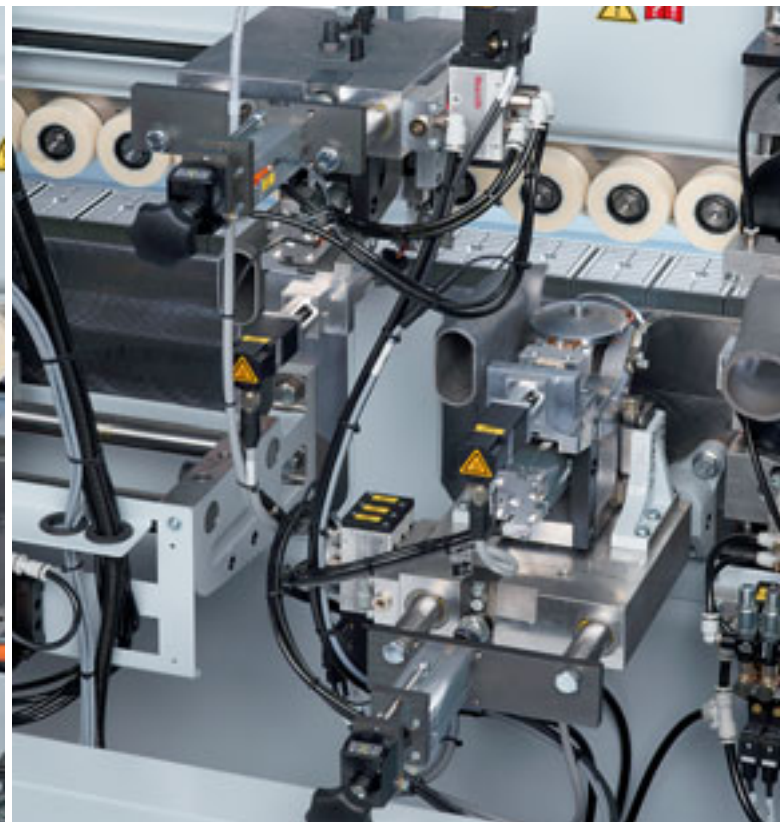
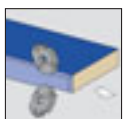

## Multistage scraping unit MZ 40 (optional)

Fully automatic adjustment between 2 different profiles by means of servo motors\*.

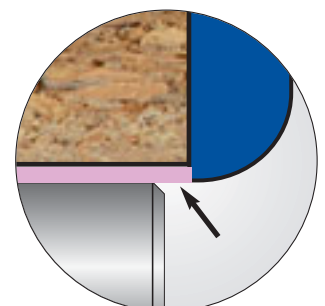
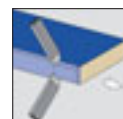

**Optimal positioning for protection foil / peelcoat materials.**

\* **Servo motors:** The servo drive consists of a motor with an infinite adjustment. The result is high performance accuracy, especially in case of short adjusting distances.

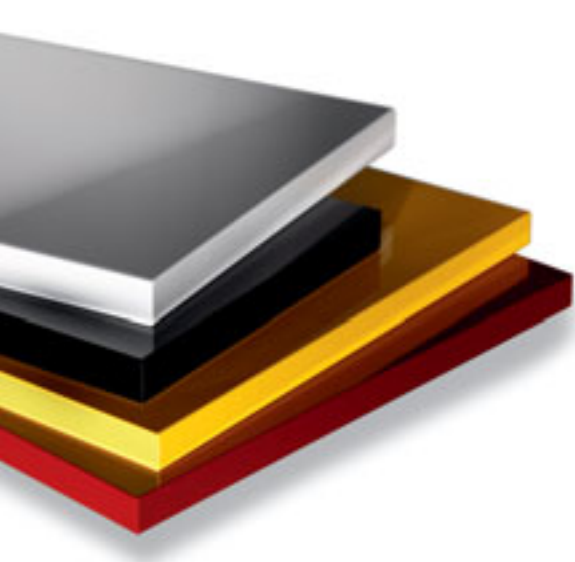

# Significant competitive advantages – Pace setting performance and quality

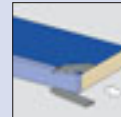

**Glue joint scraping unit (optional)**

For the perfect finish.



**Spraying unit (optional)**

Separation and cleaning devices for an optimal processing result with sensitive surfaces.

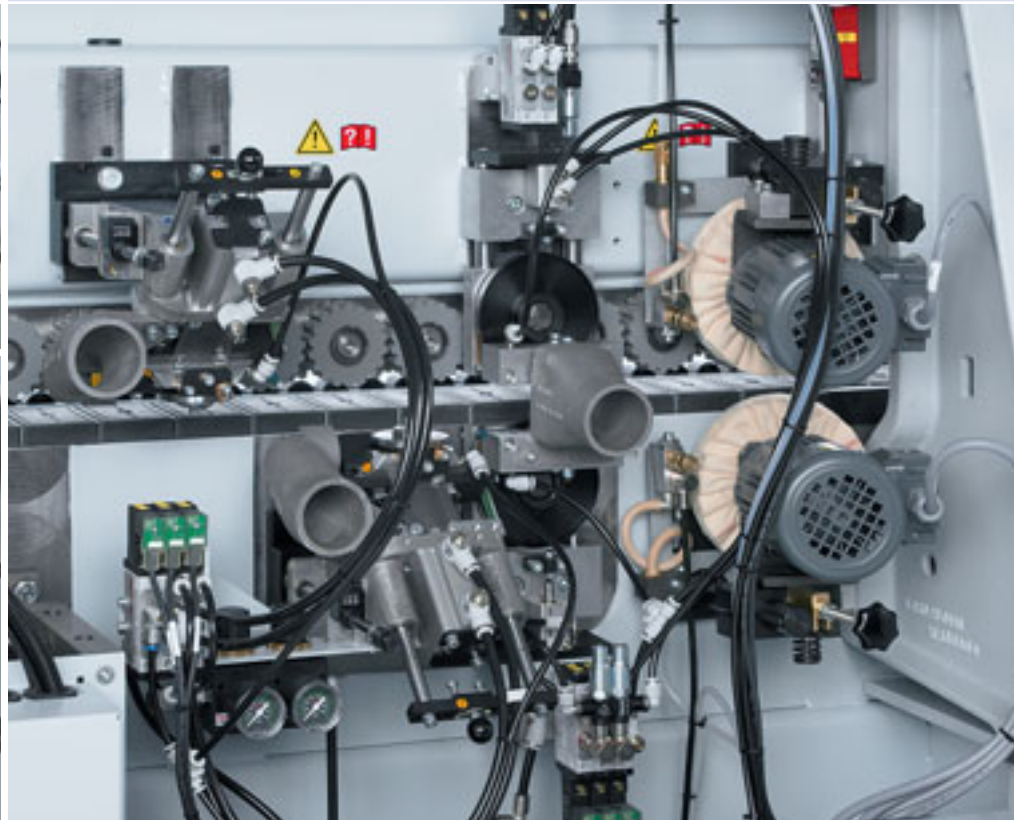

**Profile scraping unit**

Unit to smooth radii or chamfers, equipped with quick change heads for fast profile change.



**Buffing unit**

Buffing unit to polish edges and maintain their natural colour.



# Technical data

Type of machine	Highflex 1220	Highflex 1230
	<b>Machine dimensions</b>	
Machine length (mm)	4153	4773
Working height (mm)	950	
Machine dimensions WxH (mm)	1525 x 2182	
	<b>Working dimensions</b>	
Workpiece thickness (mm)	8 - 60	
Edge material thickness (mm)	0,4 - 6	
	<b>Miscellaneous</b>	
Feed speed (m/min)	11	
Weight (kg)	1290	1500
Connected value (kW)	9,8	
Extraction diameter (mm)	1x120/3x80/1x100	
Electrics	400 V - 3 Ph. - 50 Hz.	
Pneumatics (bar)	6	

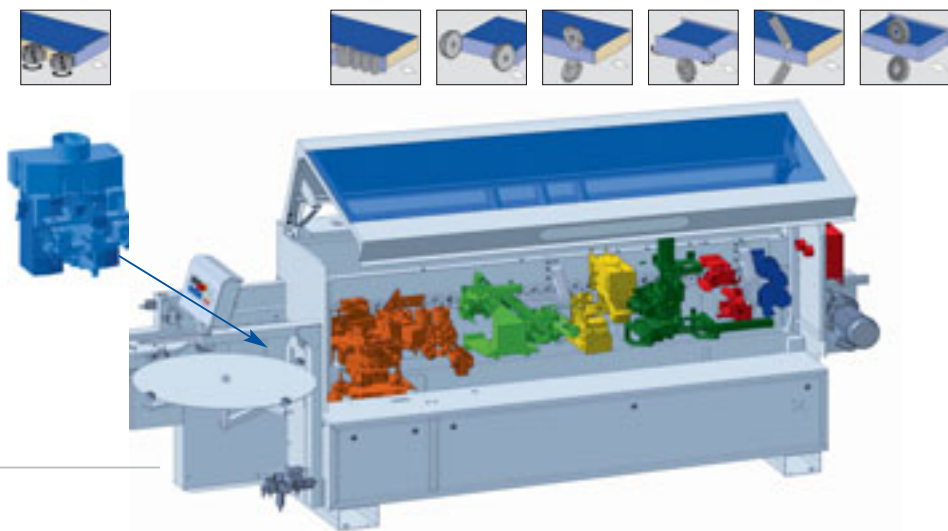

**Highflex 1220**

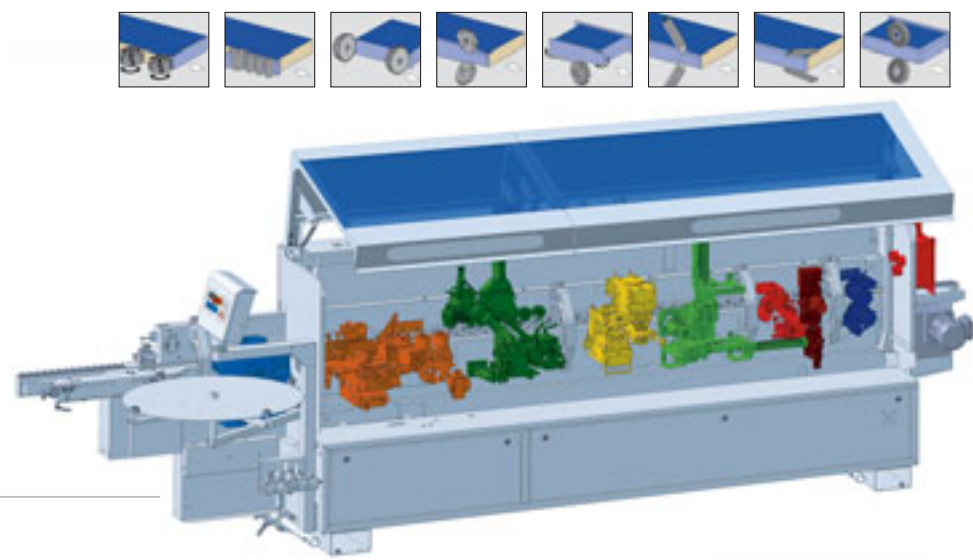

**Highflex 1230**



Type of machine	Highflex 1430	Highflex 1440
	<b>Machine dimensions</b>	
Machine length (mm)	4773	5273
Working height (mm)	950	
Machine dimensions WxH (mm)	1575 x 2182	
	<b>Working dimensions</b>	
Workpiece thickness (mm)	8 - 60	
Edge material thickness (mm)	0,4 - 8	
	<b>Miscellaneous</b>	
Feed speed (m/min)	var. 8 - 14	
Weight (kg)	1600	1850
Connected value (kW)	14,5	16
Extraction diameter (mm)	1x120/3x80/1x100	1x120/5x80/1x100
Electrics	400 V - 3 Ph. - 50 Hz.	
Pneumatics (bar)	6	

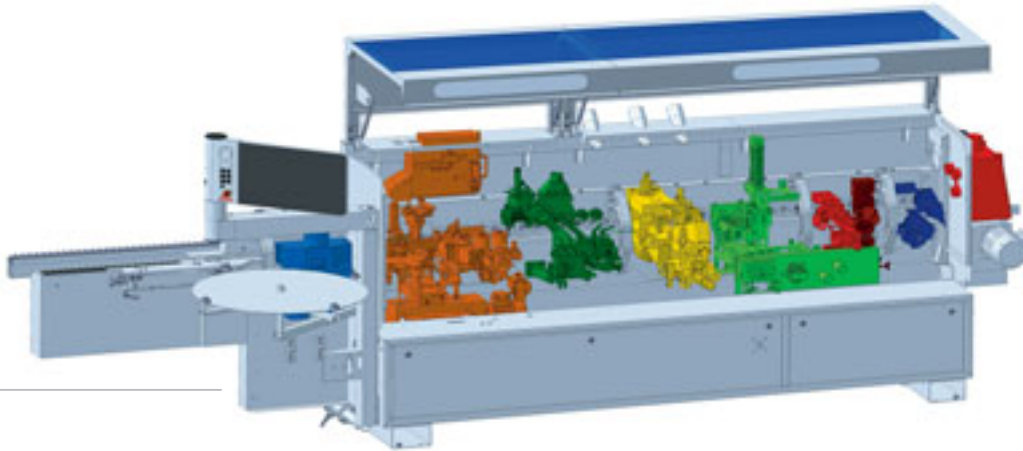
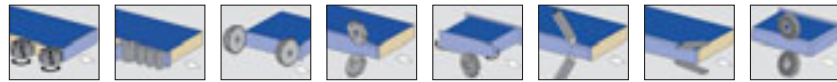

**Highflex 1430**

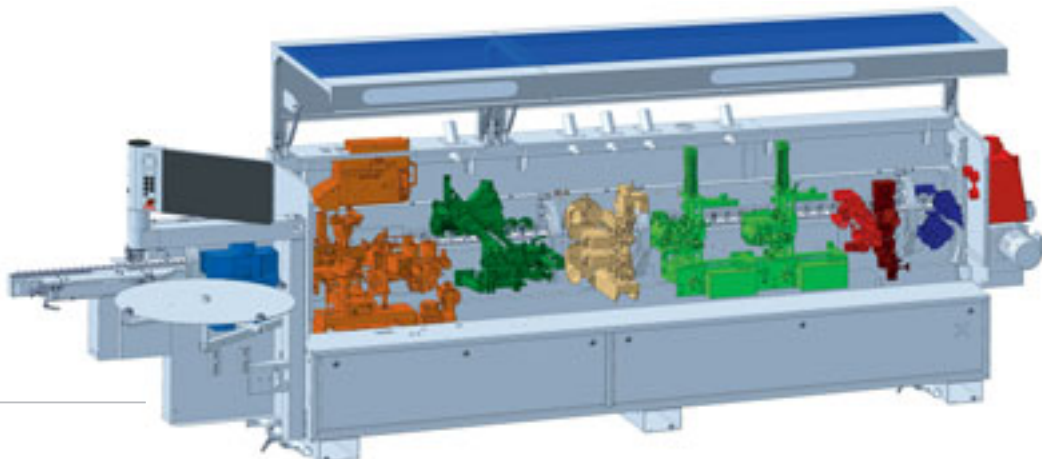

**Highflex 1440**

# Technical data

Type of machine	Highflex 1650	Highflex 1660
	<b>Machine dimensions</b>	
Machine length (mm)	5760	6260
Working height (mm)	950	
Machine dimensions WxH (mm)	1555 x 2300	
	<b>Working dimensions</b>	
Workpiece thickness (mm)	8 - 60 (optional 80)	
Edge material thickness (mm)	0,4 - 15	
	<b>Miscellaneous</b>	
Feed speed (m/min)	var. 8 - 18	
Weight (kg)	2600	3000
Connected value (kW)	23	24
Extraction diameter (mm)	1x120/1x160/1x100	1x120/1x200/1x100
Electrics	400 V - 3 Ph. - 50 Hz.	
Pneumatics (bar)	6	

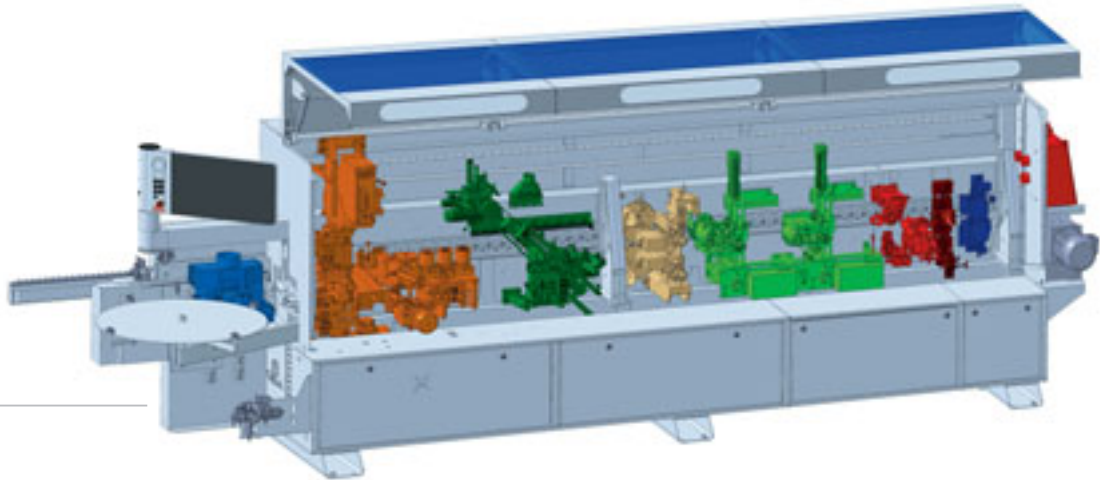
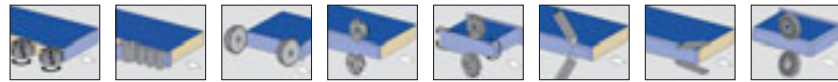

**Highflex 1650**

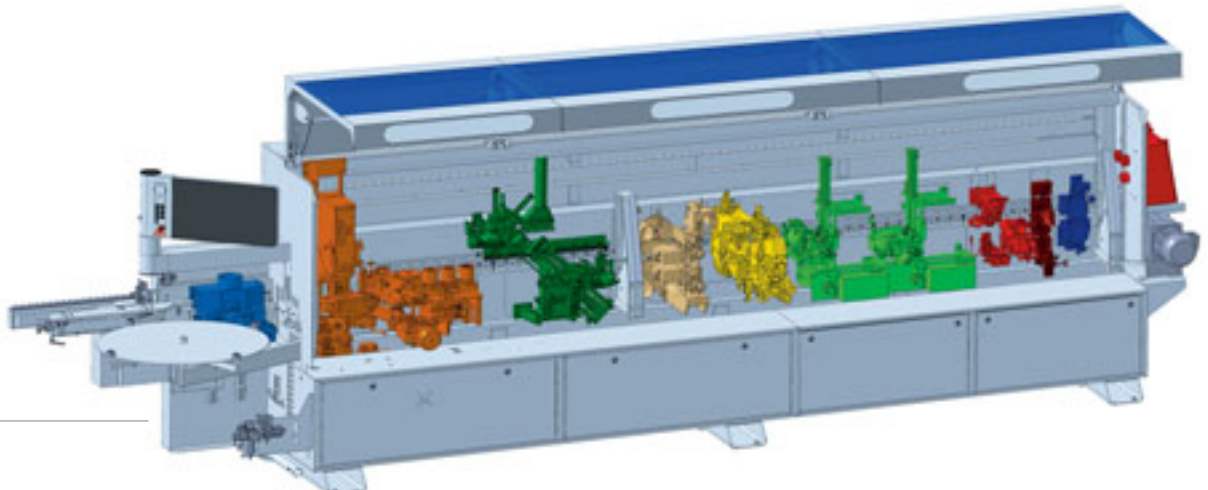

**Highflex 1660**



Type of machine	Highflex 1870	Highflex 1880
	<b>Machine dimensions</b>	
Machine length (mm)	6760	7260
Working height (mm)	950	
Machine dimensions WxH (mm)	1555 x 2300	
	<b>Working dimensions</b>	
Workpiece thickness (mm)	8 - 60 (optional 80)	
Edge material thickness (mm)	0,4 - 15 (opt. 0,4 - 20)	
	<b>Miscellaneous</b>	
Feed speed (m/min)	var. 8 - 20	
Weight (kg)	3400	3600
Connected value (kW)	26	25
Extraction diameter (mm)	1x120/1x160/1x100	1x120/1x200/1x100
Electrics	400 V - 3 Ph. - 50 Hz.	
Pneumatics (bar)	6	

All rights for technical changes withheld. Individual machine pictures may show options.

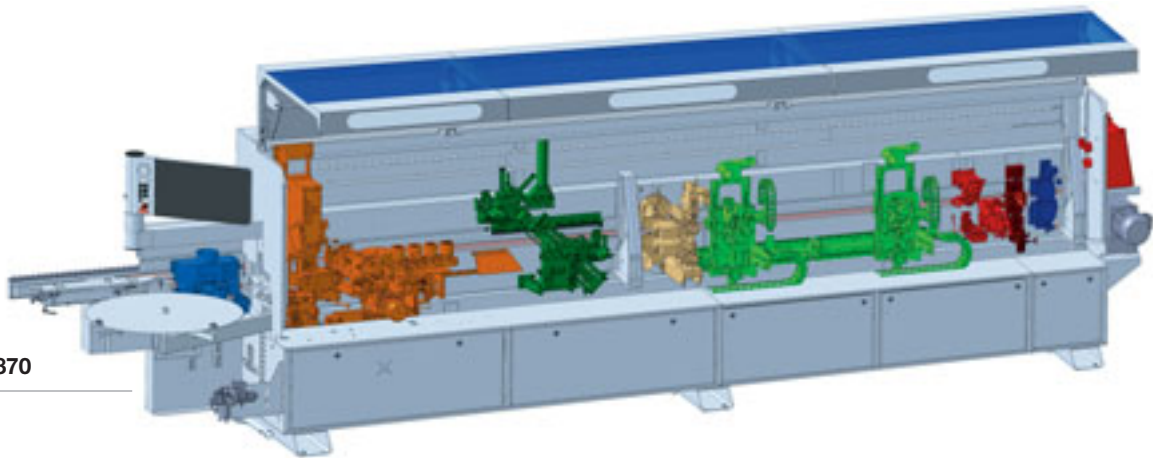
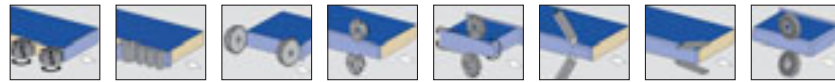

Highflex 1870

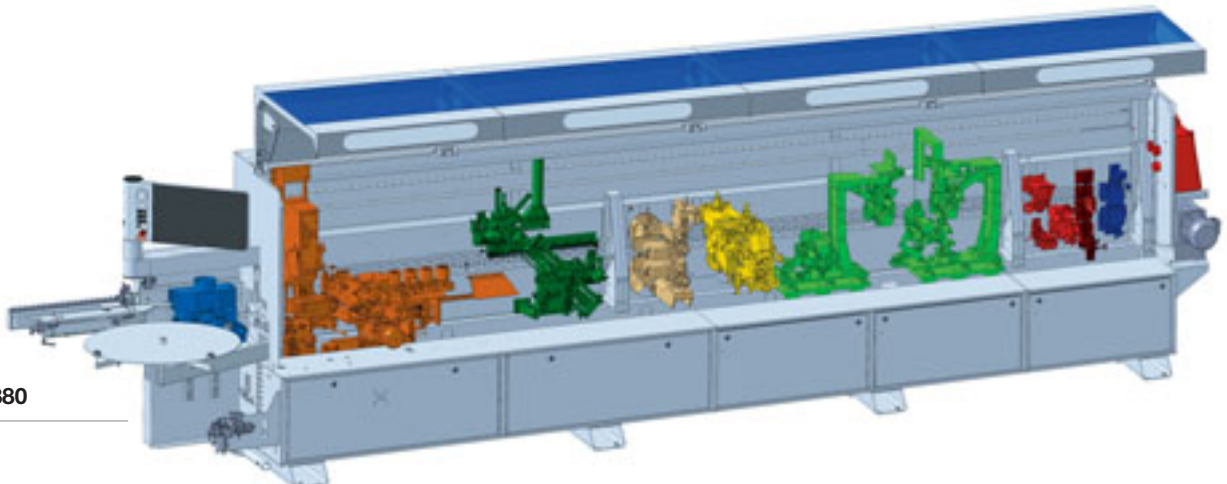

Highflex 1880

# The new gluing generation – glue application as a system

Due to today's variety of products and increasing customer's demands it has become necessary to focus on a future-oriented gluing technique. The new glue application system QA 45 meets all market requirements and offers excellent solutions for a modern interior shop or furniture production companies.

## Application unit QA 45 (optional)

- Special coating of the gluing unit for all types of glue, including PUR in order to meet all customers' requirements.
- Easy and fast change over of different types of glue through an automatic draining system, in order to make use of the ideal glue type or colour based on application.
- The automatic cleaning system is activated by the control, in order to minimize the downtime of the machine.
- Glue amount infinitely adjustable by servo motor in order to achieve a perfect result for most different workpiece materials.
- Glue application in both directions, synchronism and antirotation for a perfect adhesion of different edge materials.

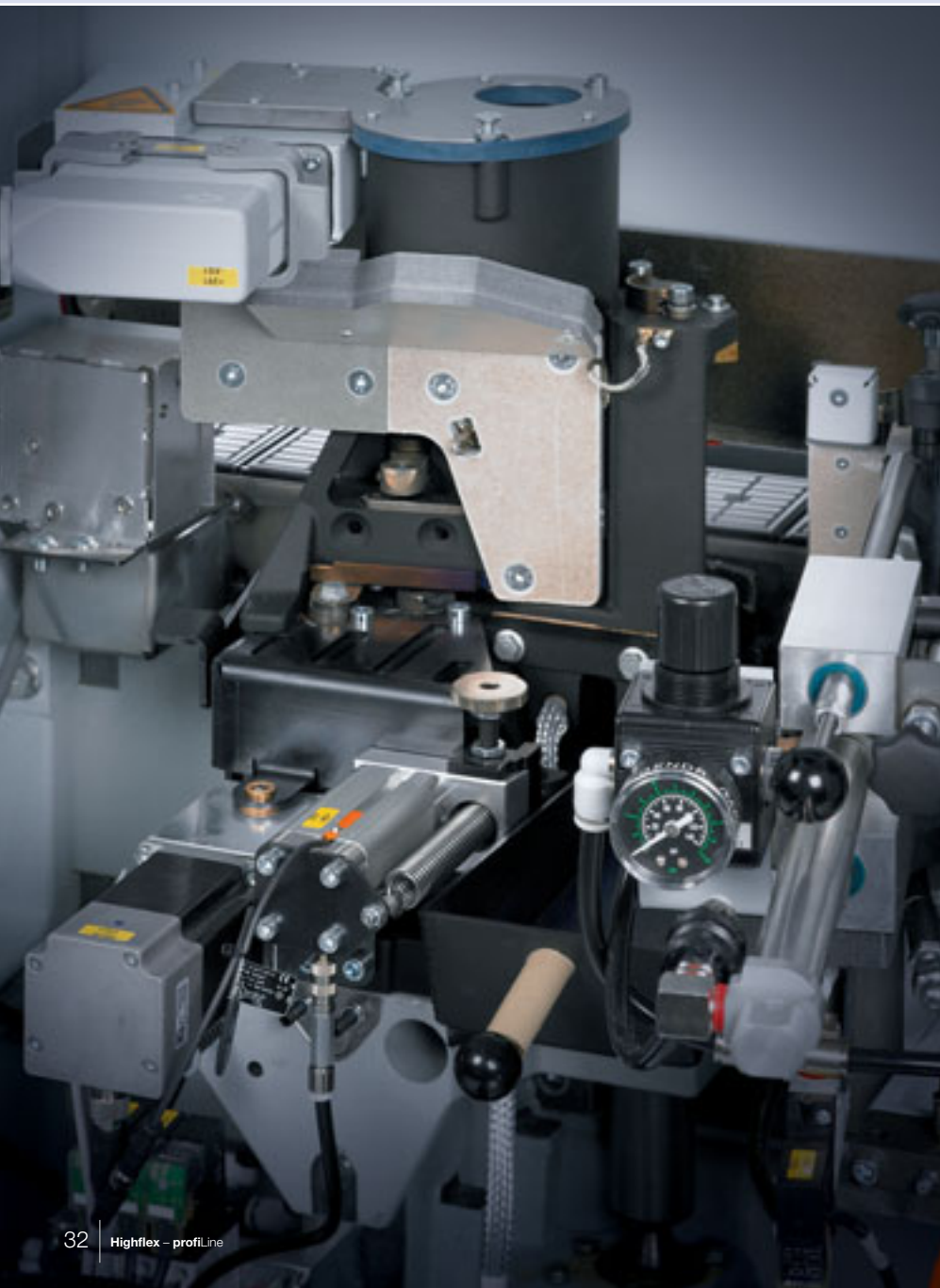

### QA 45 – Manual

- The application unit is filled by hand either with granulated glue, or with glue slugs
- Flexible application of different hot melt adhesives, like EVA, PU or Polyolefine based glue or different glue colours

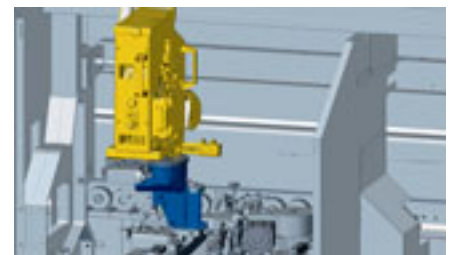

### QA 45 – EVA

- EVA pre-melting unit for hot melt glues
- Filling capacity approx. 4 ltrs. granulated hot melt glue



### QA 45 – PU

- PU pre-melting unit
- Chemcoat antioxidation coating of the glue melting container.
- Container size: 2 kg slugs



# profiLine-series

## Precision and performance for highest demands

**Our profiLine series offer always the perfect solution for your needs. Its modular design and the freely-fittable frame concept allow it to fit perfectly to your production requirements.**

**Workpiece thicknesses of up to 100 mm can be processed, allowing you to keep up with current and future trends in the industry.**

A universal trimming unit as well as a multi-stage trimming unit highlight the versatility of this machine series. The universal trimming unit offers high performance for grooving and profiling, and can be used in a very flexible manner. The multi-stage trimming unit is equipped

with servo-axis adjustments and allows for automatic changeover between four different profiles. A belt sanding unit with multiple pad capabilities is available for sanding of straight edges and radii.

**„You define the task – we configure the right machine“**



# Significant competitive advantages – Pace setting performance and quality. profiLine-series

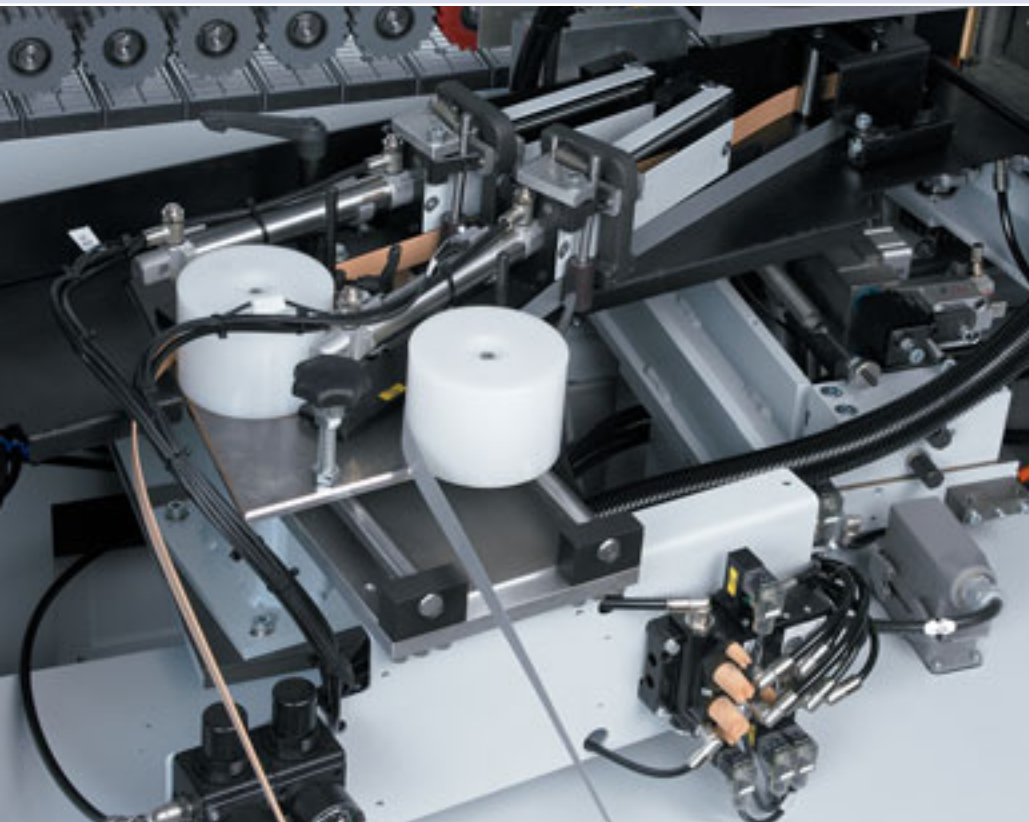

## Automatic 2-coil magazine

Automatic 2-coil magazine for the highest possible flexibility and significant time savings during edge material changeovers.

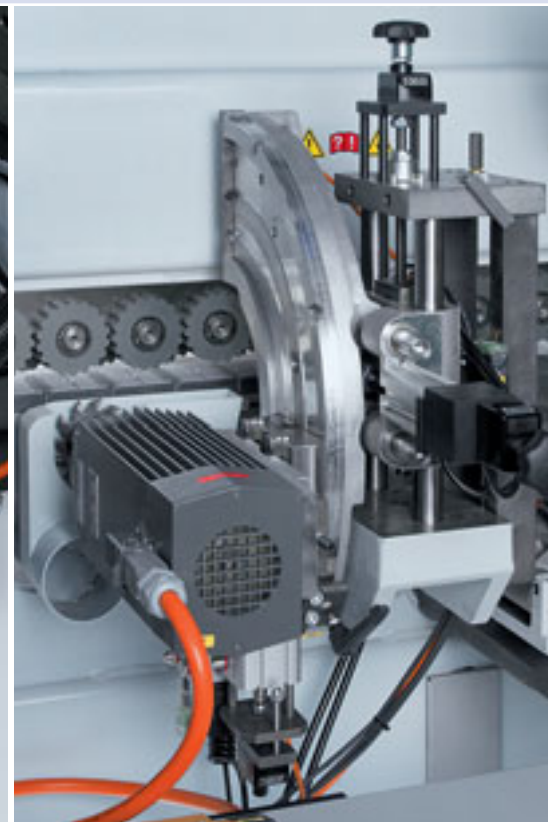
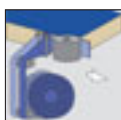

## Tiltable grooving unit

For grooving work pieces either from the bottom side or from the edge side. It is possible to do either continuous grooving or non continuous grooving, as well as jump grooving for biscuit joints.

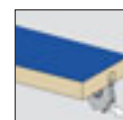

# Multistage technology – flexible results for high demands

The spectrum of edge and panel material is growing continuously, which means that the requirements of our customers are increasing, too. No matter what materials you use: plastic, solid wood, veneers and high gloss surfaces. The multistage trimming and scraping units always offer the ideal radius and the best results.



1. Straight

2. Profile 1

3. Profile 2

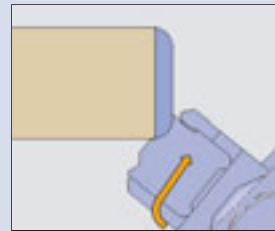

1. Profile 1

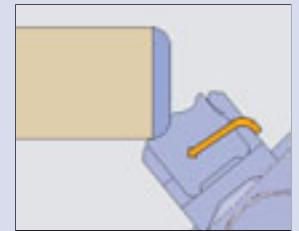

2. Profile 2

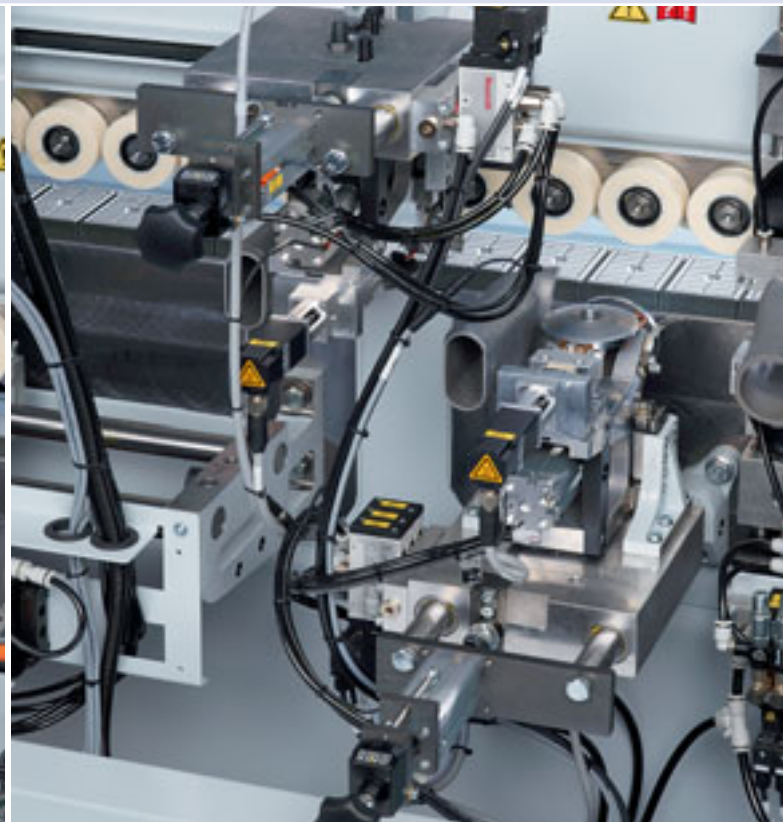
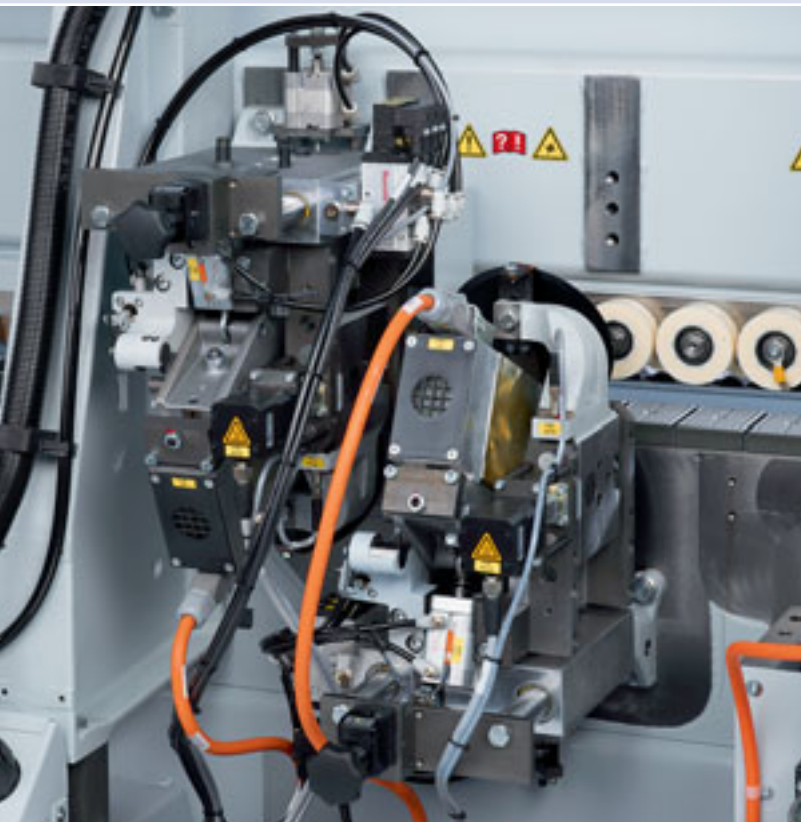

## Multistage trimming unit MS 40/45

Fully automatic adjustment between 3 different profiles by means of servo motors\*.

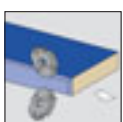

## Multistage scraping unit MZ 40

Fully automatic adjustment between 2 different profiles by means of servo motors\*.

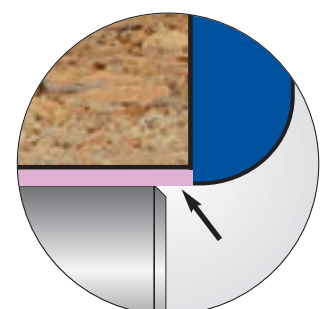
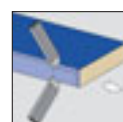

**Optimal positioning for protection foil / peelcoat materials.**

\***Servo motors:** The servo drive consists of a motor with an infinite adjustment. The result is high performance accuracy, especially in case of short adjusting distances.

# Significant competitive advantages – Pace setting performance and quality. profiLine-series



## Multifunctional trimming unit MF 50

Trimming of the edge overhang on top and bottom side as well as contour trimming on the front and rear edges. Equipped with an automatic adjustment to switch between thick and thin edges. Workpiece thickness up to 60 mm.

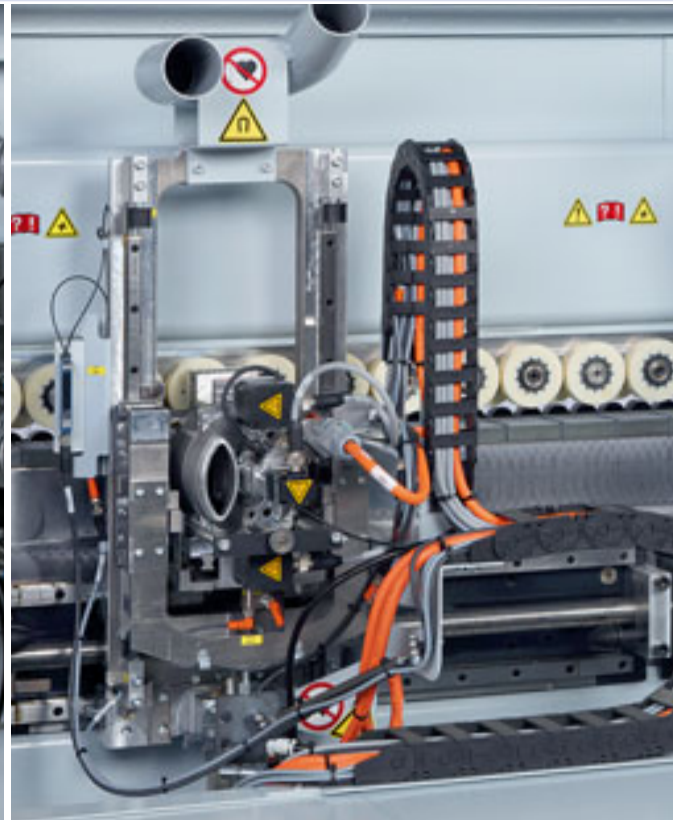

## Multifunctional trimming unit MF 60 Servotrim

For processing the edging overhang at the upper and lower edge of the workpiece as well as for corner rounding of the front and rear edge. Servo-controlled movement with soft-touch function for optimal handling of e.g. high gloss surfaces or light weight panels. Workpiece thickness up to 100 mm.





**Spraying unit**

Separation and detergent agents for a perfect finish when processing PU-glue.



**V-belt top pressure (optional)**

Top pressure V-belt system optionally available instead of the standard top pressure roller system.



**Sanding unit**

For sanding straight edges on different materials



**Universal trimming unit**

Universal unit with high capacity for grooving and profiling work. Flexible by unlimited setting options.

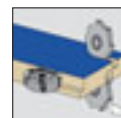

# BOOMERANG® return systems TFU 120 and TFU 140/20: Higher productivity for your BRANDT Edge Bander

As an indispensable assistant the return system renders your BRANDT Ambition even more economic. With the one-man-operation you optimize the workpiece return and allow a lean and efficient production process. Depending on the requirements you can combine your BRANDT machine of the Ambition 1600 series with a TFU 120 or TFU 140/20 model.



## BOOMERANG® TFU 120

The entry to a comfortable material flow.

**By the way:**  
The BOOMERANG® already pays off within one year, in fact starting from an operation of 9 hours per week!

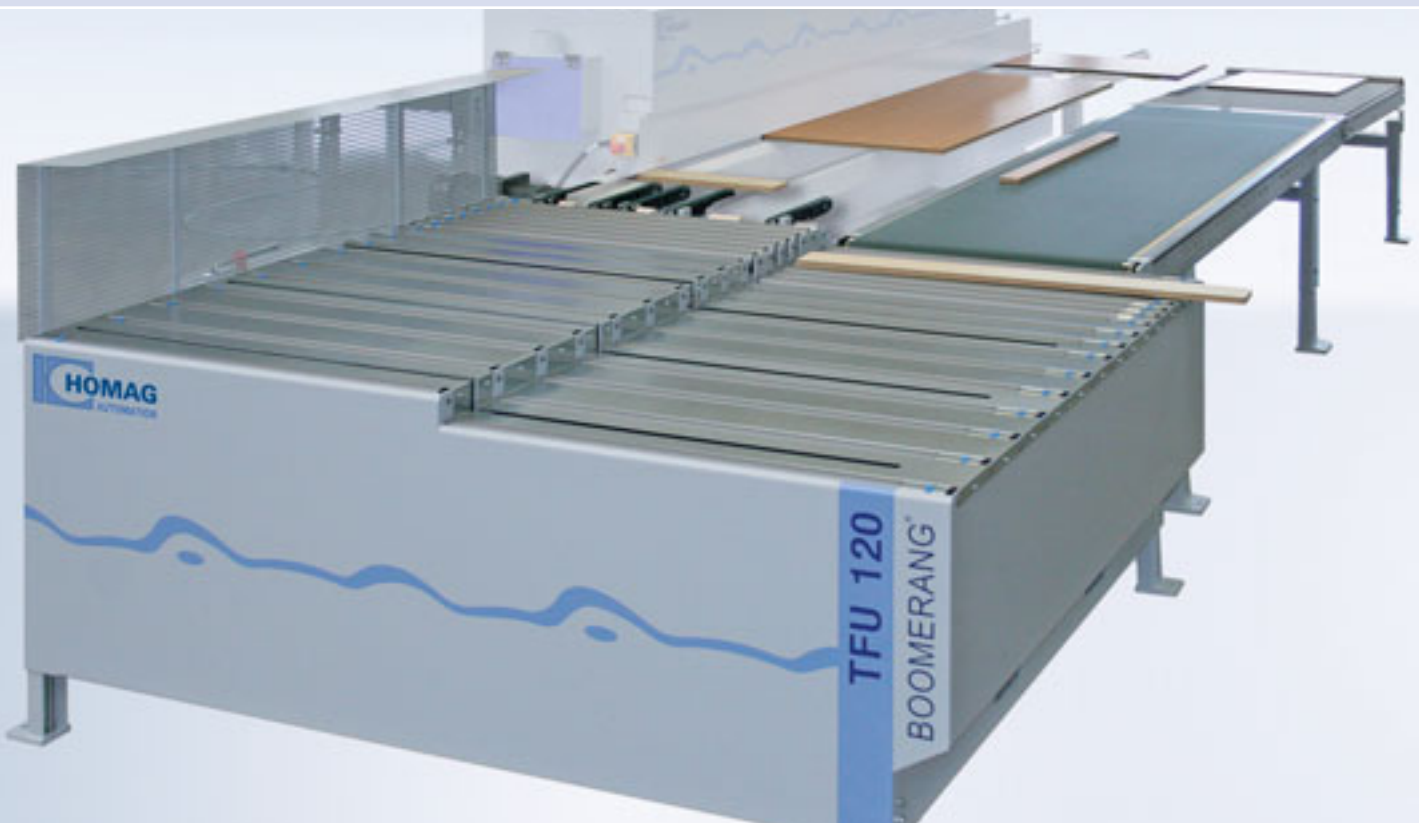

**Excellently suited for customers with small, narrow, and medium-sized workpieces**

### The advantages at a glance:

- Fast amortization - pays off from 9 hours working time per week
- No training necessary - assemble the BOOMERANG®, connect it, and get started
- Flexible operator organization - thanks to economic one-man operation
- Ergonomic operation - operator will be released from heavy physical work
- Better quality control - fast reaction to material adjustments

	TFU 120
Workpiece length	300 - 2500 mm
Workpiece width	50 - 1450 mm
Workpiece thickness	8 - 60 mm
4-sided processing*	
min. workpiece dimension	300 x 300 mm
max. workpiece dimension	1450 x 1450 mm
Weight	max. 50 kg
Feed speed	8 - 25 m/min

\*Larger workpieces can be returned or fed out for 4-sided processing with manual assistance for the transverse offset and turning.



### Belt cleaning

For optimal protection against dust and chips.



### CE Package

Safety engineering equipment for the protection of the employees.



### Sensor-controlled pivot pins (option, TFU 120)

For easier rotation of short and narrow workpieces.



### Air cushion table with stroke (option, TFU 140/20)

At the outfeed of the return system for ergonomic workpiece handling.



### BOOMERANG® TFU 140/20

For a wide spectrum in the material flow.

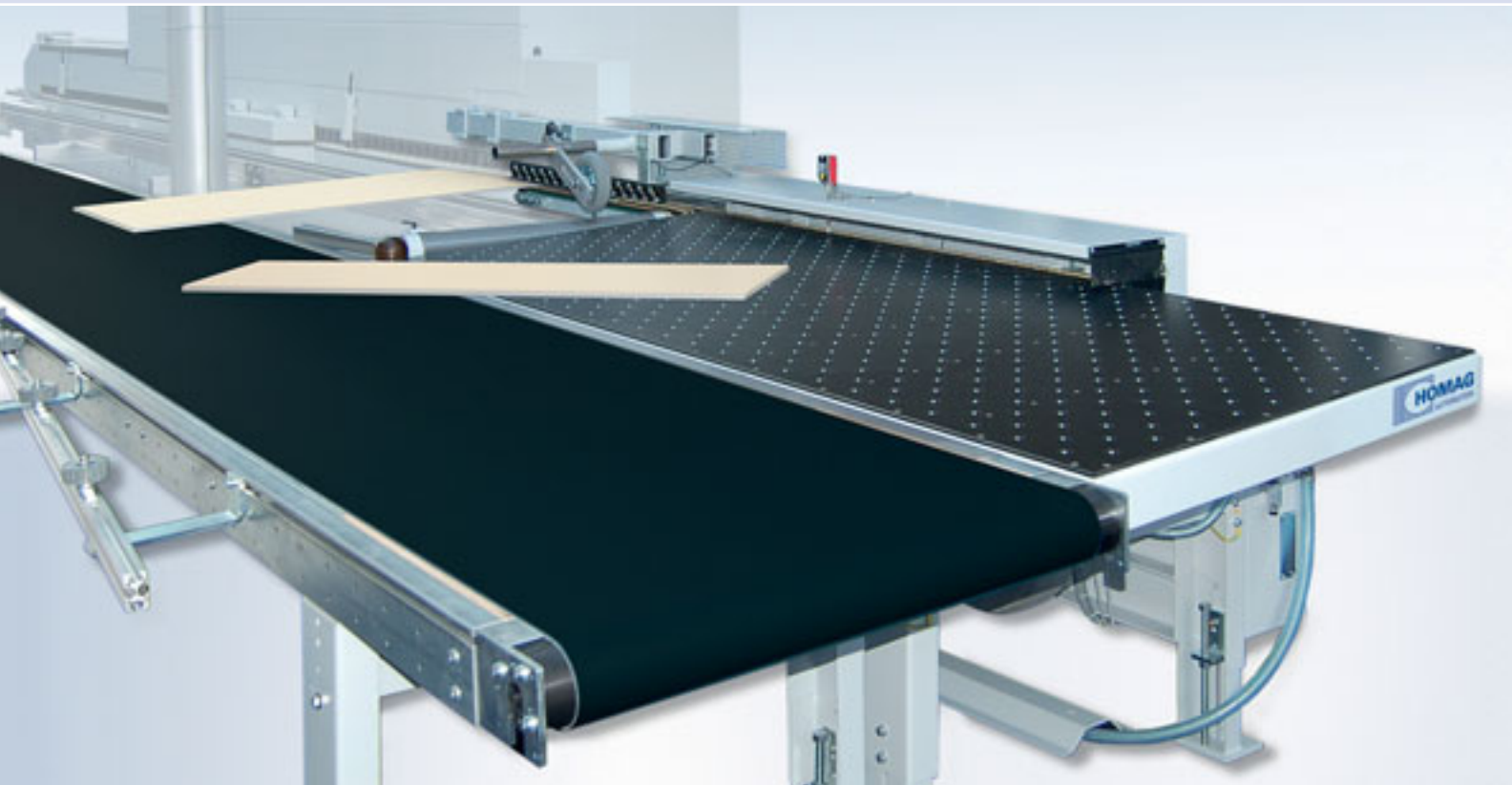

	TFU 140/20
Workpiece length	300 - 2500 mm
Workpiece width	60 - 800 mm
Workpiece thickness	8 - 60 mm
4-sided processing*	
min. workpiece dimension	300 x 300 mm
max. workpiece dimension	2000 x 800 mm
Weight	max. 50 kg
Feed speed	8 - 30 m/min

\*Larger workpieces can be returned or fed out for 4-sided processing with manual assistance for the transverse offset and turning.

### Best suited for customers with high material variety - from small and light up to large and heavy workpieces

#### The advantages at a glance:

- Fast amortization - pays off from 15 hours working time per week
- Low quality costs - gentle workpiece handling with air cushion table
- No training necessary - assemble the BOOMERANG®, connect it, and get started
- Flexible operator organization - thanks to economic one-man operation
- Ergonomic operation - operator will be released from heavy physical work



A member of the Homag Group of Companies



**BRANDT**  
**Kantentechnik GmbH**  
Weststraße 2  
32657 Lemgo  
Germany  
Tel. +49 5261 974-0  
Fax +49 5261 6486  
info@brandt.de  
<http://www.brandt.de>



**HOMAG**  
**Automation GmbH**  
Ligmatech Str. 1  
09638 Lichtenberg  
Germany  
Tel. +49 37323 16-0  
Fax +49 37323 17-170  
info@homag-automation.com  
[www.homag-automation.com](http://www.homag-automation.com)