

**CONCEPT**

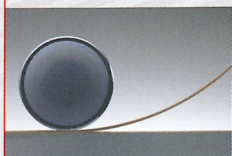

# Novimat **Concept**

for premium edge banding



Novimat **CONCEPT**  
Quality  
Productivity  
Flexibility



### Novimat **CONCEPT – R**

- for coil material up to 3 mm thickness

### Novimat **CONCEPT**

- for coil material up to 3 mm thickness and solid wood strips up to 20 mm thickness

Novimat **CONCEPT – For high-quality processing.**

**The Novimat CONCEPT has a comprehensive modular system of processing units for customer driven equipped machines:**

- ❖ **High edge quality and performance through servo technology**
- ❖ **Attractive price-performance ratio**
- ❖ **Quick set-up system, due to fixed panel overhang in the finishing section**
- ❖ **High precision and stability**
- ❖ **Optimum performance and long lasting operational life**

Edge quality and high performance through servo technology

# IMA MFA [Multi-Function Unit]

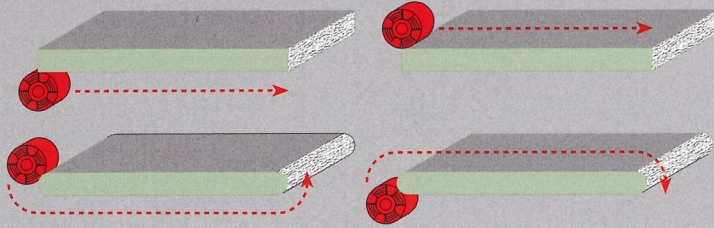

The IMA MFA's of the Novimat CONCEPT offer you decisive competition advantages:  
High quality, fast and flexible edge processing.  
Length wise as well as for the second pass with contour trimming.

Horizontal and vertical motion of the unit is carried out by servo-drives.

- ❖ Maximum product quality
- ❖ Optimum productivity
- ❖ Maximum machine life through quality production techniques

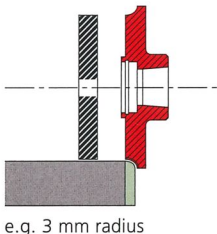
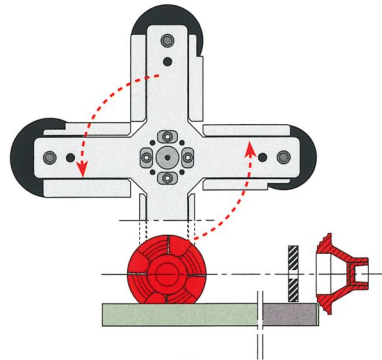

e.g. 3 mm radius

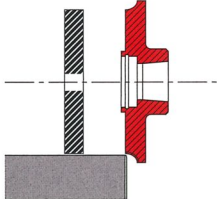

e.g. 15° chamfer, adjustable to any edge thickness (0.4 – 3.0 mm)

## IMA MFA 08.342

- Radius and chamfer milling
- Manual positioning of the milling motor for chamfer milling (optional: NC adjustment)
- Chamfer milling adjustable to the edge thickness
- Milling motor with quick-change system for easy set-up in case of various radii

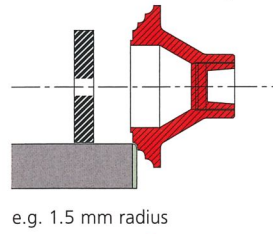

e.g. 1.5 mm radius

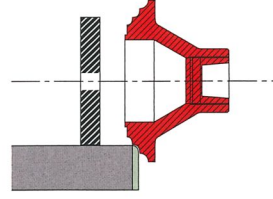

e.g. 2 mm radius

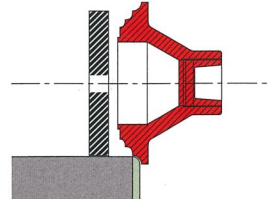

e.g. 3 mm radius

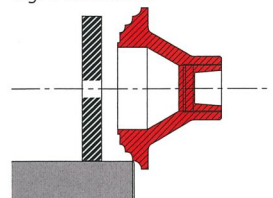

e.g. 15° chamfer, adjustable to any edge thickness (0.4 – 3.0 mm)

## IMA MFA 08.348

- Automatic set-up of 4 different edging profiles (3 radii and 1 chamfer) using a multi profile tool designed to reduce set-up times
- Chamfer milling adjustable to the edge thickness' through PC-controlled horizontal milling motor positioning

Novimat **CONCEPT** – The single-sided automatic  
edge banding machine for jointing, edge banding  
and finishing in throughfeed operation



Infeed table



**WORK PIECE FEEDING  
AND HANDLING**

Efficient and precise feeding of work pieces,  
as well as work piece return systems for  
one-man operation for best possible design  
of the material flow.

Joint milling unit 08.378



Pre-milling unit 08.0555

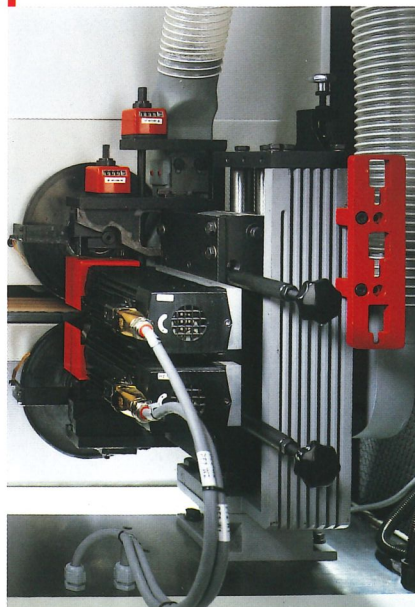

Fine-/Profile milling unit 08.055



# Novimat **CONCEPT** Basic equipment

**EDGE BANDING**  
Novimat **CONCEPT**  
Edge-banding unit 283.1513  
with *quick-lock glue applicator*  
for coil material up to 3 mm and  
solid wood strips up to 20 mm  
Quickmelt system  
1 main pressure roller  
5 additional pressure rollers

Novimat **CONCEPT - R**  
Edge banding unit 04.1570  
with *quick-lock glue applicator*  
for coil material up to 3 mm  
Quick-melt system  
1 main pressure roller  
4 additional pressure rollers



Novimat CONCEPT – edge banding unit 283.1513 (picture)  
[Novimat CONCEPT – R – edge banding unit 04.1570]

## Novimat: **The modular system of processing units** for customer driven machine design

approx. 2,400 – 6,300 mm (7' 10" – 20' 8")

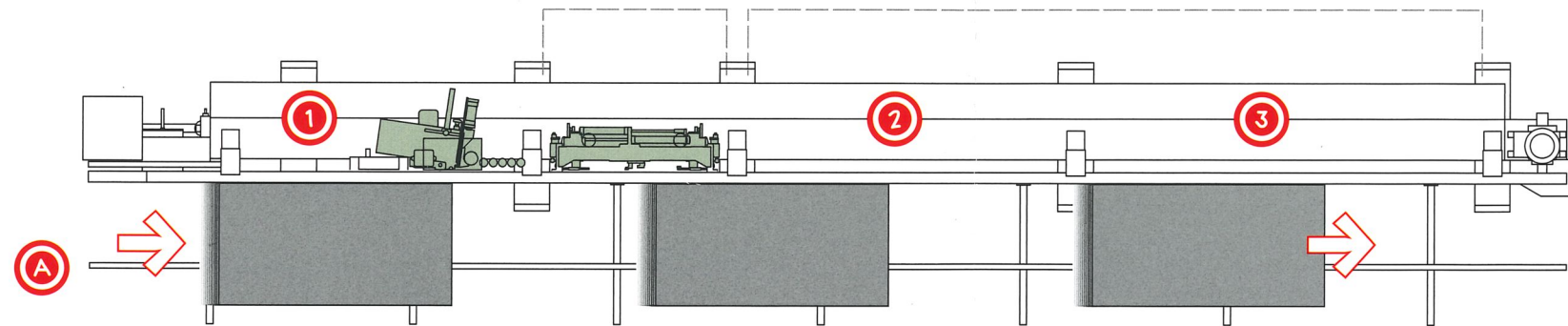

### ① JOINTING

- Joint milling unit 08.376

Multi-profile milling unit 08.0587

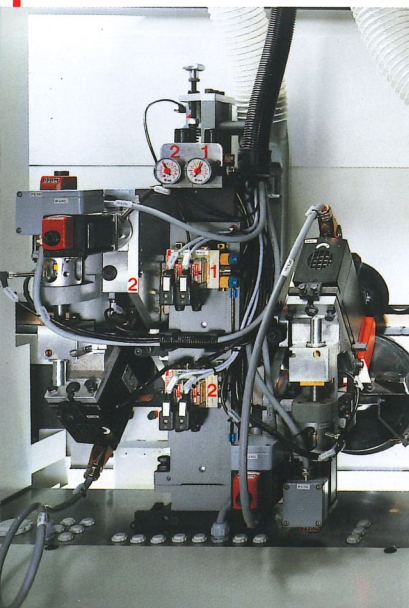

MFA 08.342

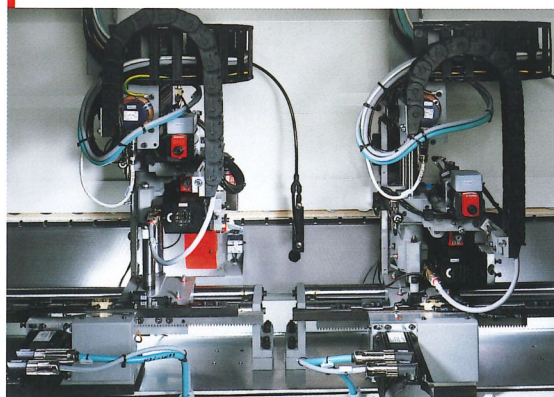

MFA 08.348

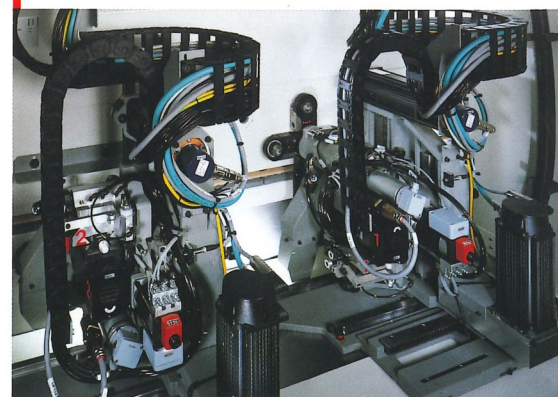

Contour  
trimming unit 08.471

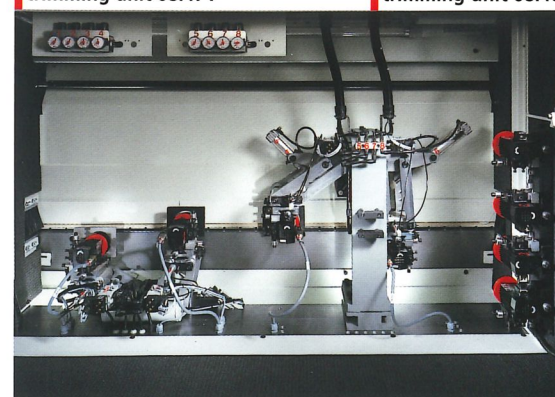

Contour  
trimming unit 08.461

Profile  
scraper unit 08.515

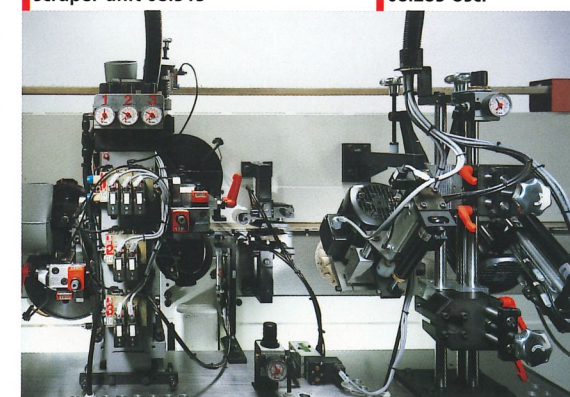

Flat scraper unit 08.50

Buffing unit  
08.285 osc.

Multi-profile scraper unit  
08.516

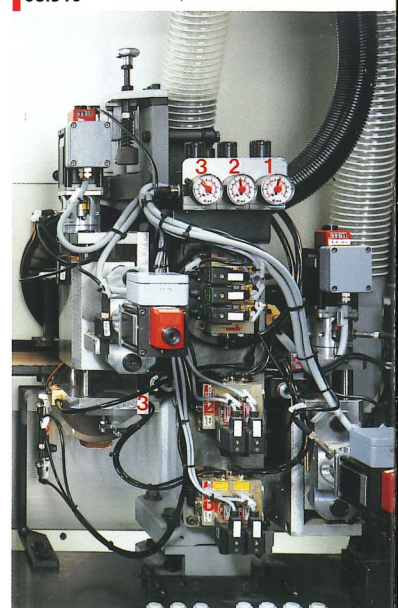

## END TRIMMING

End trimming unit for straight and chamfer trimming

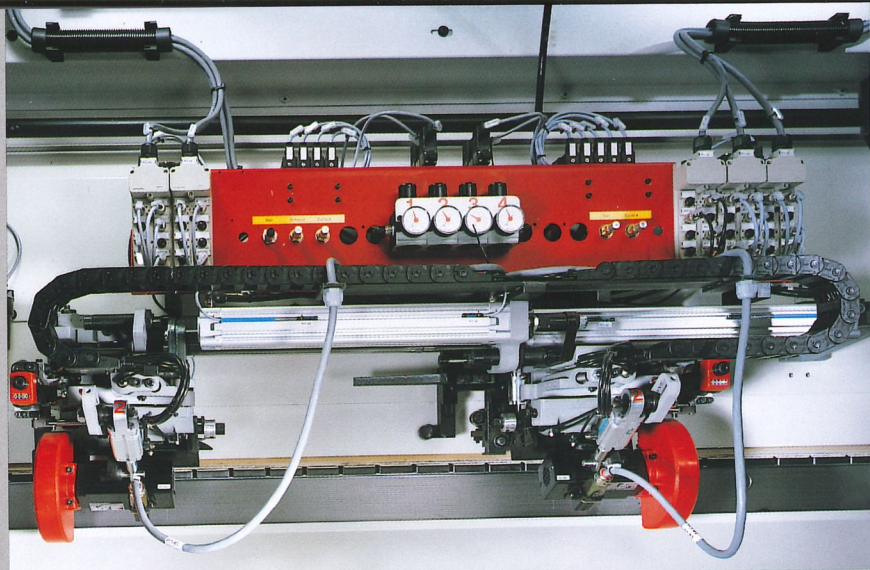

End trimming unit

## ② MILLING + CONTOUR TRIMMING

- **Milling unit 08.0555**  
(pre-milling)
- **Milling unit 08.055** or **multi-profile milling unit 08.0587**  
(fine milling / profile milling)
- **MFA 08.342** or **MFA 08.348**  
(fine milling / profile milling + contour trimming)
- **Contour trimming unit 08.471 + 08.461**  
(contour trimming)

## ③ FINISH | GROOVING + REBATING

- **Profile scraper unit 08.515** or **multi-profile scraper unit 08.516**
- **Flat scraper unit 08.50**
- **Buffing unit 08.285** oscillating
- **Contour buffing unit\***
- **Smoothing unit 08.53**
- **Grooving unit 08.183**
- **Sanding unit 08.062**
- **Radius sanding units 08.063**  
(top + bottom)

\* without picture

Smoothing unit 08.53

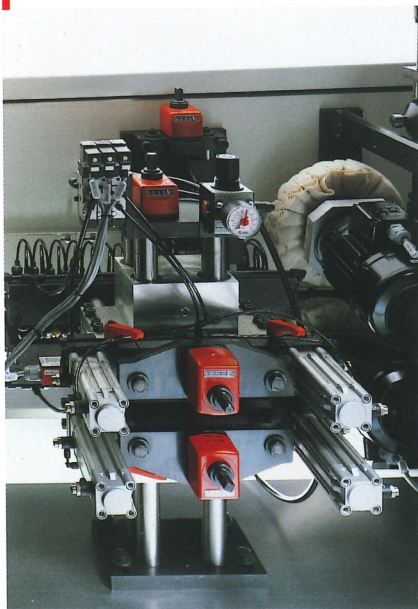

Grooving unit 08.183

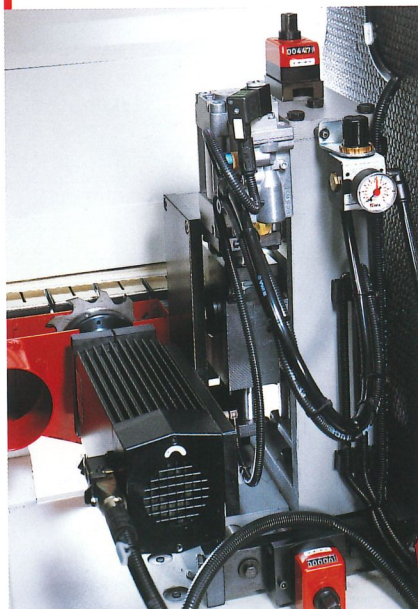

Radius sanding unit 08.063  
(top unit) (bottom unit)

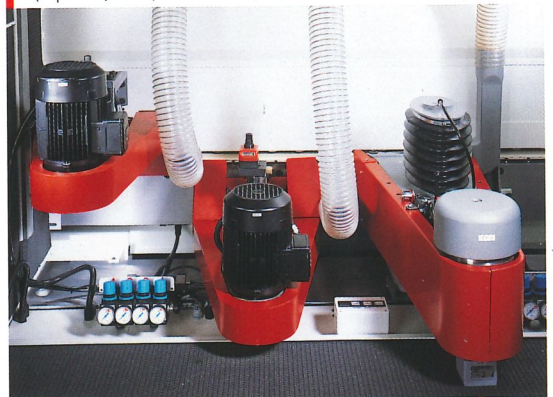

Sanding unit 08.062

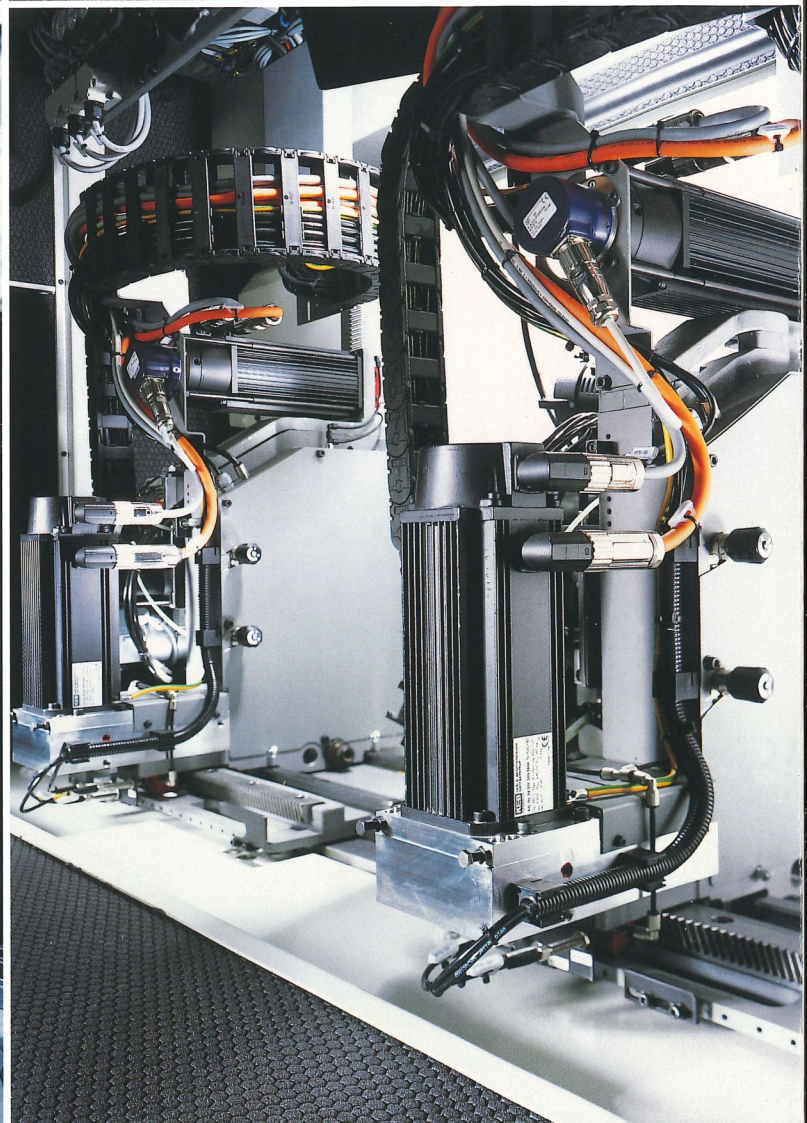
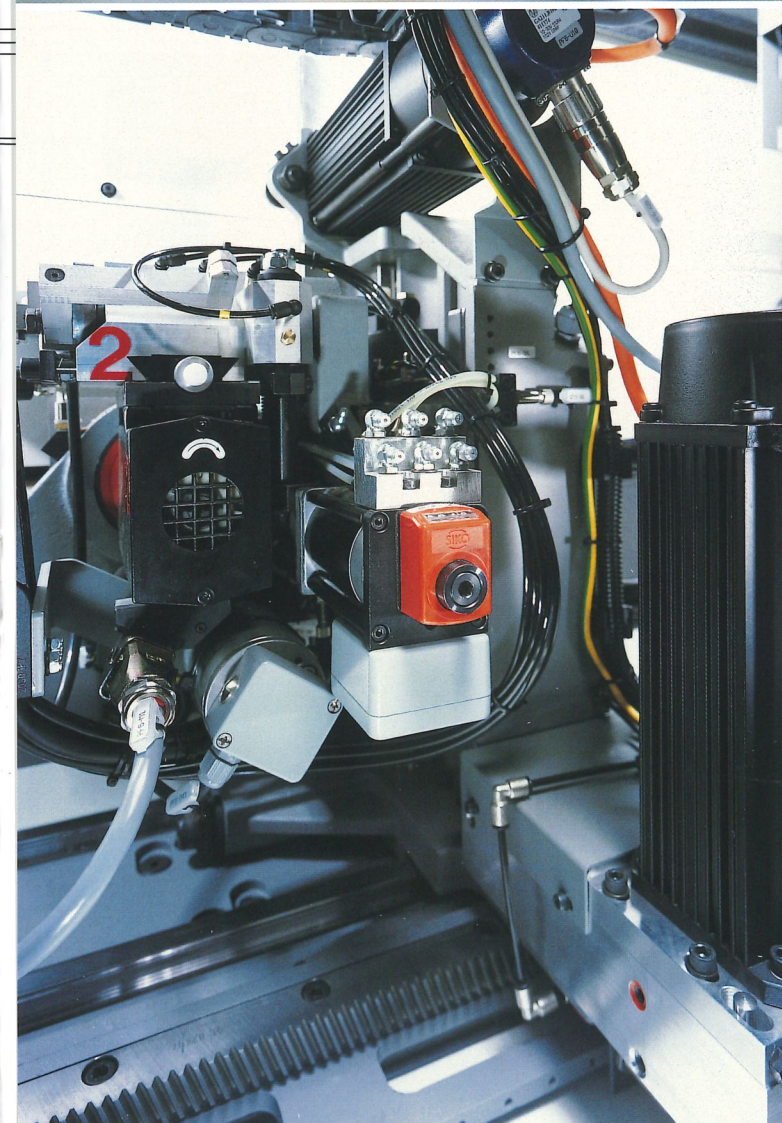
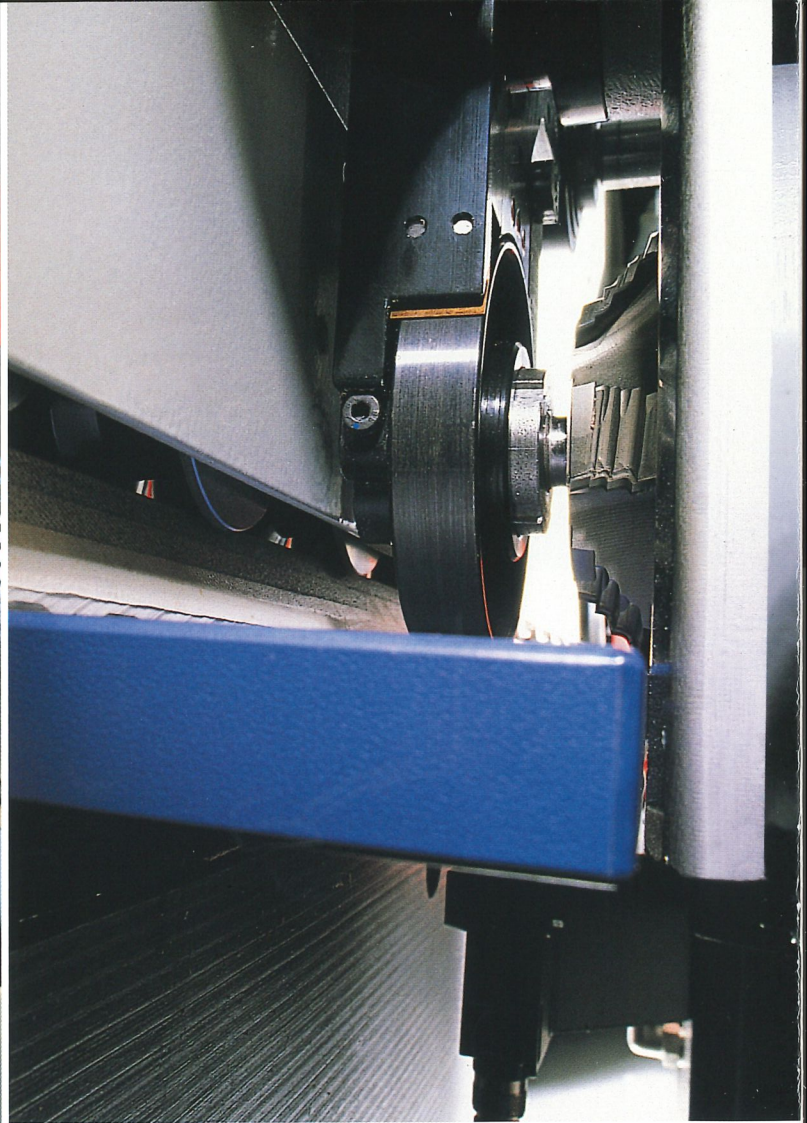
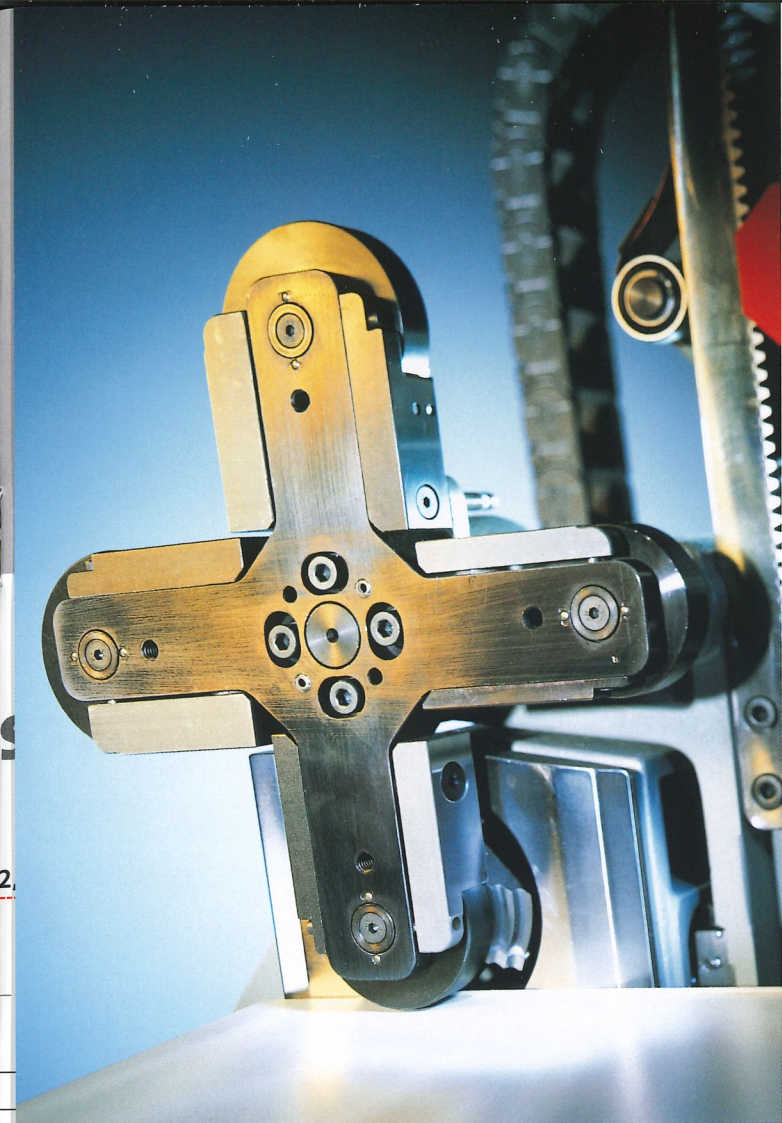

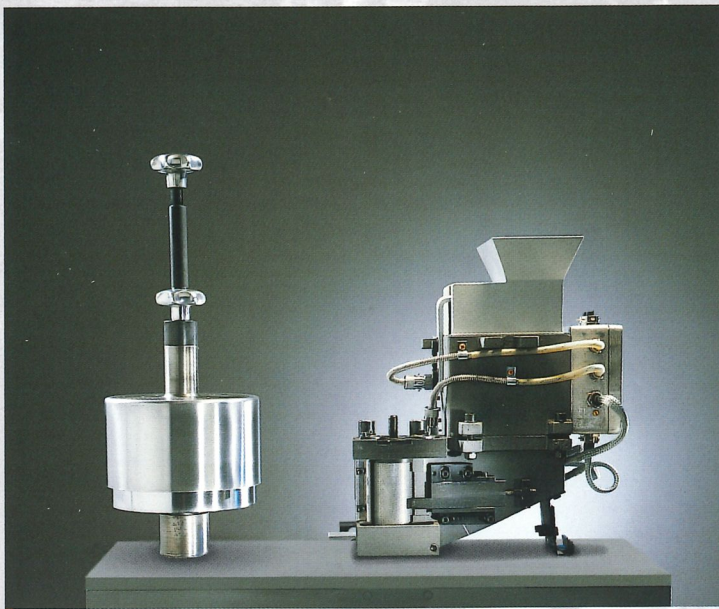

Novimat CONCEPT – R 3 – Edge banding unit 04.1570  
 [Novimat CONCEPT L 20 – Edge banding unit 283.1513]



IMA quick-lock glue applicator

Glue applicator change in a few seconds with the

## IMA *quick-lock system*

Various decorative surfaces, as well as high quality demands, require an optimised use of glue colours and types. IMA offers with the *quick-lock system* an economic and user-friendly solution.

The glue applicator is replaced within seconds.

The pneumatically controlled quick connect joint is user-friendly and a safe interface between the glue applicator and the gearbox.

PUR hot-melt glue

Easy use of water and temperature-resistant

PUR hot-melt glue

❖ Quick set-up with quick-lock glue applicator

- ❖ Cost-effective melting of the PUR adhesive using the PUR Quick-melt system for 2 kg packages or the PUR pre-melting unit for 310 g cartridges
- ❖ Applicator for anti-stick solvent and cleaning agent for a high quality finish

PUR-Quick-melt





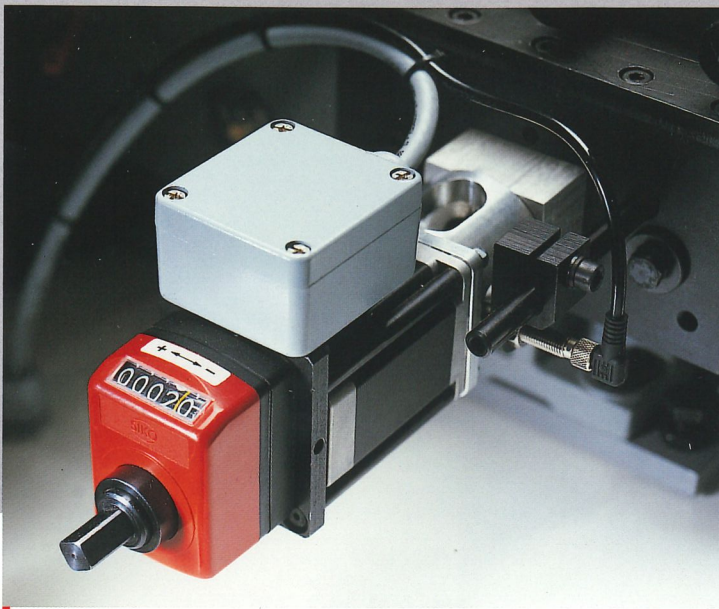

PC-controlled adjustments using NC axis motors



Icos open

# Control system Icos open

The advanced PC-controller, Icos open, with integrated PLC and electronic line control, guarantees easy use, programming, control and monitoring of machine functions.

- ❖ User friendly surface, similar like windows™
- ❖ Individual program names
- ❖ Almost unlimited program memory (capacity of hard disk)
- ❖ Input of production sequence via keyboard / mouse.
- ❖ Storage of tool data
- ❖ Main drive interlocked with neighbouring machines or conveyors
- ❖ Fast data exchange between PC and I/O-components via optical cable
- ❖ Teleservice function
- ❖ Standardized interfaces and programming language (IEC 61131)

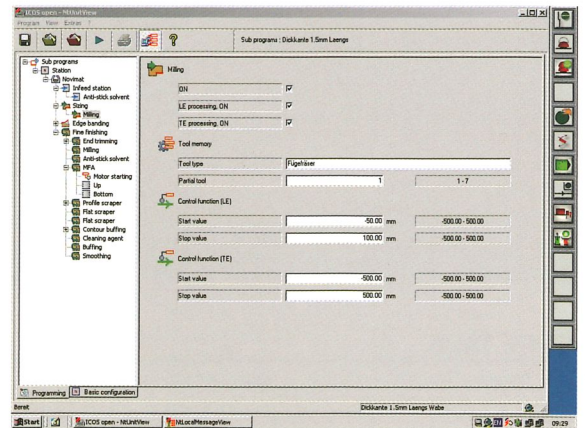

# Novimat **CONCEPT** – Main characteristics

## Novimat **CONCEPT** – R

## Novimat **CONCEPT**

### MACHINE

Track speed*	6 – 30 m/min	6 – 30 m/min
Fixed panel overhang from the chain track (including the edging)	38 mm	38 mm (with edging thickness' 0.4 – 8 mm)

### WORK PIECE

Panel thickness	min. 8 mm max. 40 mm (with contour trimming) max. 60 mm (without contour trimming)	min. 8 mm max. 40 mm (with contour trimming) max. 60 mm (without contour trimming)
Panel width (including the edging)	min. 65 mm	min. 65 mm (with edging thickness' 0.4 – 3 mm)
Panel length	min. 130 mm	min. 130 mm

### EDGE TAPE

Tape height	min. 14 mm max. 65 mm	min. 14 mm max. 65 mm
Tape thickness	min. 0.4 mm max. 3 mm	min. 0.4 mm max. 20 mm
Tape cross section	max. 120 mm <sup>2</sup> for coil material	max. 120 mm <sup>2</sup> for coil material max. 20 x 55 mm for solid wood strips
Tape length	min. 250 mm for coil material up to 3 mm	min. 160 mm for coil material up to 3 mm min. 350 mm for solid wood strips up to 20 mm

\* the max. track speed rate depends on the end trimming and contour trimming units as well as on the MFA units.

Subject to technical alterations and developments. The offer, respective order confirmation, is in any case the only relevant machine description. The photographs may show the machine without complete safety equipment. However safety equipment will be supplied. Photographs may show options, which are not part of the standard execution.

Version 01/2007

### POWER SUPPLY + COMPRESSED AIR SUPPLY

Power supply	3/N, 400 V +5/-10 %, 50 Hz
Control voltage	24 V
Compressed air	8 bars

### OTHER MACHINE CHARACTERISTICS

Fixed side / Left-hand machine	(right-hand machine can be supplied at additional price)
Machine colours	<ul style="list-style-type: none"> <li>• Basic machine and acoustic enclosure: RAL 9002 grey white – satin, smooth</li> <li>• Safety covers: RAL 3001 red – structural</li> <li>• Working units: RAL 7037 dusty grey – structural and smooth</li> <li>• Motors: RAL 9005 black – satin</li> <li>• Control cabinet: RAL 7032 pebble grey</li> </ul>



**IMA Klessmann GmbH**  
Holzbearbeitungssysteme  
P.O. Box 12 46, D-32292 Lübbecke  
Industriestraße 3, D-32312 Lübbecke  
Germany  
Fon +49 57 41331-0  
Fax +49 57 4142 01  
<http://www.ima.de>  
contact@ima.de