

Intelligent success is sustainable success. And clearly a matter for forward thinkers.

Behind the fascination of every moment that nature offers us with its complex beauty there is always a concept for tomorrow. We at WINTERSTEIGER have learned a lesson from this. All our developments are characterized by a holistic forward-looking approach which is well thought through and completely sustainable. The DSB Singlehead and DSB Twinhead NG XM are good examples of this.

Thanks to their flexible design and their extremely low cutting loss, the latest generation of WINTERSTEIGER thin cutting band saws offers customers amazing performance while at the same time boosting efficiency. These gains result from savings in both materials and machine time that have a positive effect for any kind of application. No matter whether you are cutting wood or alternative materials, wet or dry conditions, irrespective of plank dimensions or XXL formats, requests for a single cut or a high-capacity production line – WINTERSTEIGER assures the most precise cut with the lowest possible material loss.



Contents:

DSB Singlehead	4
Standards	6
Options	10
Technical data	13
DSB Twinhead NG XM	14
Standards	16
Options	20
Technical data	22
Saw blades from in-house development and production	23
Remote Service	24
After Sales Service	25
WINTERSTEIGER WOODTECH	26
WINTERSTEIGER Worldwide	27

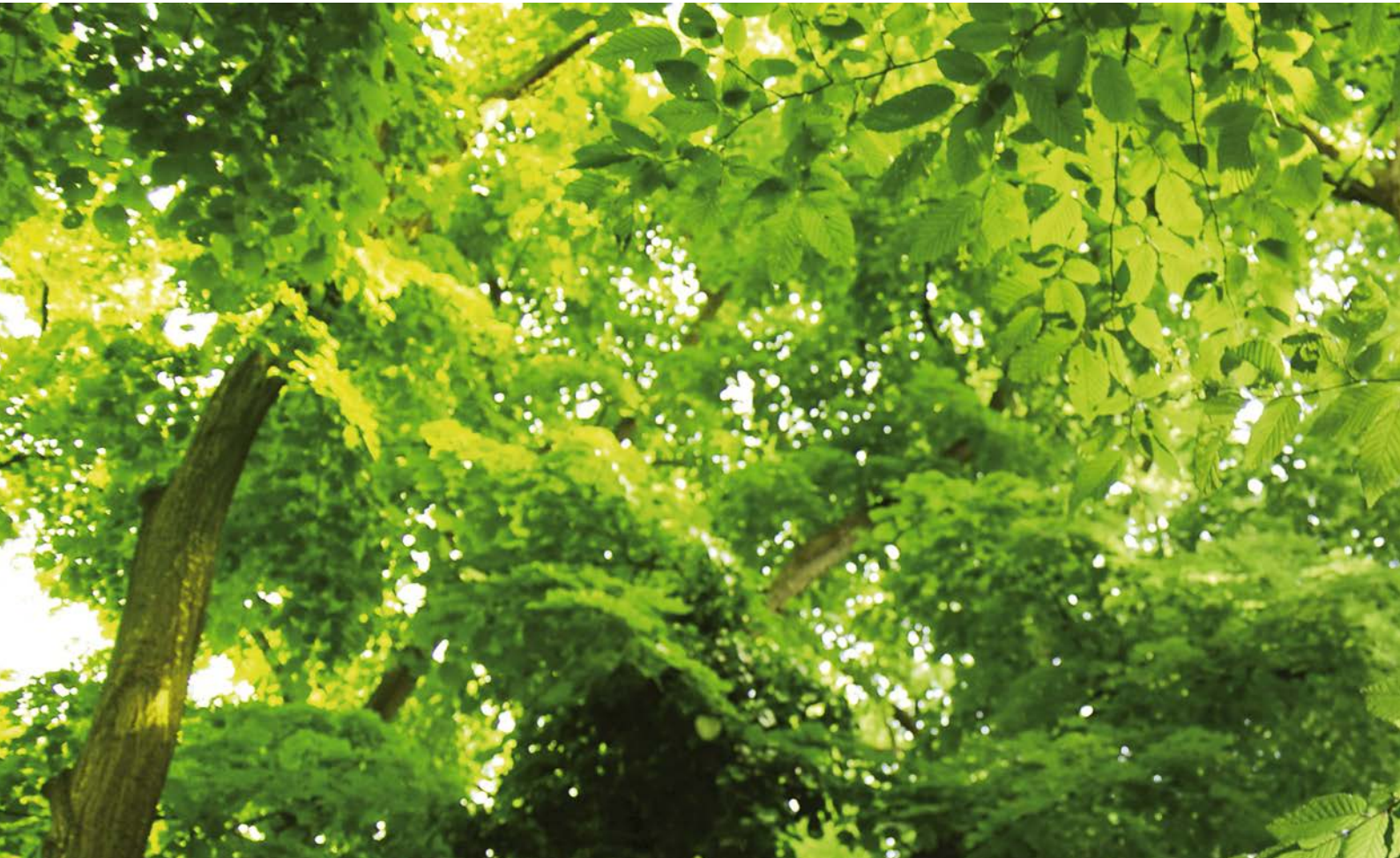

DSB Singlehead

Single-module thin-cutting band saw.

Maximum precision for unlimited flexibility and economy.

The DSB Singlehead thin cutting band saw from WINTERSTEIGER is the ideal solution for unlimited applications in high-quality thin cutting.

Numerous features make the difference. For example a revolutionary feed system designed to ensure a continuous transport for any block conditions. Or the remarkable durability of the saw blade guides. These and many more new features make sure to have the ultimate operating efficiency when working with the new DSB Singlehead. Moreover, the DSB Singlehead combines absolute precision with superior performance, for the production of high-quality lamellas as well as for any other thin-cutting request:

- Parquet flooring / Engineered floors
- Multi-layer boards
- Glue-laminated wood
- Doors
- Windows
- Furniture
- Pencil slats
- Ski/snowboard components
- Musical instruments
- Saw mill - secondary cut

If you are looking for customized solutions for non-wood materials, please ask us!



Your benefits summed up:

Unique block guiding for dry and wet cutting

- Driven feed rollers top and bottom
- Supporting table entirely hard chrome plated
- Processing of any block characteristics

Cutting-edge sawing systems for highest precision

- Long lasting high-tech carbon guide
- Option of straight or inclined saw blade position
- Structure cutting for individual surfaces

Unrestricted flexibility and efficiency

- Lamella thickness from 1.3 mm
- Maximum capacity and optimized wood yield
- For individual capacity requirements

How to exceed high expectations? By being able to offer benefits as standard.

Every investment must be given due consideration. Economic criteria are the deciding factors. Even the basic version of the DSB Singlehead incorporates an incredible variety of product features as standard. They guarantee you flexibility, precision and the ultimate operating efficiency.

Unique block guiding for dry and wet cutting.

Innovative feeding system.

Driven feed rollers top and bottom guarantee a continuous block feeding despite extreme workpiece characteristics. The feed rollers, rubber-shored and special treated, and the highly innovative counter-pressure loaded

system guarantee optimum grip as well as minimum friction for wet or dry material. At the same time, the hard chrome-plated supporting table ensures that the workpiece is as stable as possible (optimal aligned).

The feed rollers are electronically controlled and infinitely adjustable at the in-feed and out-feed (4 – 20 m/min). The vertical stabilization of the workpiece in the cutting area is the basis for the maximum precise cut.



Blocks with longitudinal/latitudinal deformation, cupped or warped



Driven transport rollers top and bottom

The DSB Singlehead owes its unusually high level of precision to the hard chrome-plated supporting table. Additional driven pressure rollers immediately above the cutting area guarantee the constant stability of the

workpiece across its full width. This gives you the ability to cut not only pre-planed material, but also uneven and rough-sawn-blocks with longitudinal or latitudinal deformations, twisted, bend or cupped.



Block dry cutting



Block wet cutting

Highest precision for unrestricted flexibility and efficiency.

Cutting-edge sawing systems for highest precision.

The saw blade guiding system is individually adjustable to match the workpiece width. This unique flexibility guarantees optimum saw blade tension in the cutting area resulting in maximum cutting precision.

High-tech carbon guide.

This high-tech composite material made of abrasion-proof carbon fibers and heat-resistant epoxy resin guarantees precise blade guiding and an extremely long lifetime.

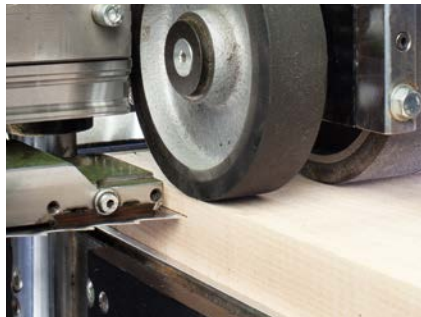

Extremely abrasion-resistant high-tech carbon guide

Option of straight or inclined saw blade position.

The machine design allows optionally offsetting the block in-feed by approx. 2° to the saw blade. A less hard saw blade entry into the material is provided, especially when cutting wide dimensions.

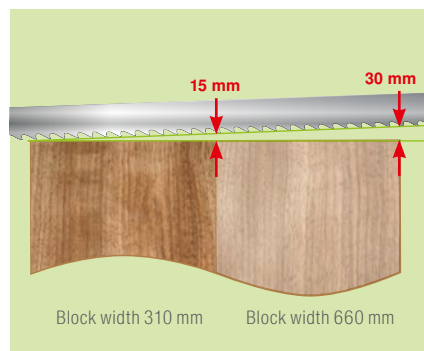

Inclination > 2° reduces the maximum cutting width

Inclination of up to 12° available on request.

Structure cutting for individual surfaces.

Our motto: individuality with maximum quality. You choose a specific surface texture and WINTERSTEIGER will produce the corresponding band-saw blade.

The special design of the tooth geometry allows you to create both regular and irregular surfaces for one-of-a-kind flooring surfaces in wellness areas, bathrooms, patios, etc.



Profile of finished surface



Finished surface

Unrestricted flexibility and efficiency.

Lamella thickness from 1.3 mm.

The highly innovative combination of thin saw blades along with a precise saw blade guiding and a sturdy block feeding system makes it possible to produce extremely thin lamellas. Thanks to this masterly technical performance, the DSB Singlehead closes the gap between classic veneer and high-quality saw veneer.



Great operating comfort.

The DSB Singlehead is impressively easy to use. The touch screen display and the easy-to-understand menus guide the user through the program. Practical: The software includes a memory function for regularly recurring cutting parameters.

It also features a multilingual user interface as well as numerous service and help menus. Programs are available for cutting, wood type and saw blade, for example, along with production data logging, diagnostics and maintenance displays.



Ultimate operating efficiency and easy maintenance.

Maintaining the DSB Singlehead is also very convenient. All service-related components of the feeding and discharging units are fully accessible – for rapid change of tools and quick adjustment work.

Versatile wood program.

Using the DSB Singlehead's special wood program, you can store the cutting, lamella and saw blade parameters for each wood type and retrieve them as needed.

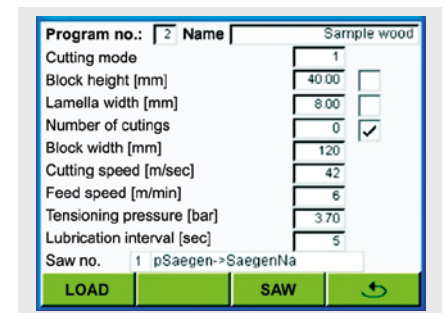

All components are fully accessible

DSB Singlehead 660 – for even greater cutting width.

The DSB Singlehead provides convincing benefits in everyday use. Most notably, its efficiency and versatility turn out to be indisputably unique selling propositions.

By developing the DSB Singlehead 660, WINTERSTEIGER has increased the operating efficiency of this type of machine. The DSB Singlehead 660

cuts lamellas up to a width of 660 mm, with a cutting kerf starting at 1.0 mm, and a lamella thickness of 1.3 mm. This is what distinguishes the machine

from others, for instance when cutting wide plank flooring or panels.



Driven transport rollers top and bottom

For the DSB Singlehead 660, the proven block transport system of the DSB Singlehead 310 was duplicated. The maximum block clearance height is 165 mm, with a cutting height of up to 100 mm.

Depending on the configuration, the feed speed of the DSB Singlehead 660 is infinitely variable up to 15 m/min.

We make you a clear offer. And still leave you the freedom to choose.

The quality of an offer lies not only in its clearly redeemable value promise. Its quality also increases with the opportunity to choose, for example, between options which further improve the result depending on individual needs.

Powerful 32 kW main drive.

When dimensional and capacity requirements grow, more power is the only answer. In this case, WINTERSTEIGER recommends the powerful 32 kW quality motor as the main drive.

The perfect feed for all applications.

For high-performance requirements at maximum capacity ranges, the DSB Singlehead allows high-speed feeding from 8 to 45 m/min.

For higher precision, special applications, sensitive materials or XXL dimensions, feeding can be reduced to speeds from 1 to 15 m/min.



DSB Singlehead Shuttle

Modular flexibility.

The DSB Singlehead's modular design ensures outstanding flexibility. Extensible from a single-module machine for highest flexibility to multiple modules, set up as an in-line operation. Additionally, automation and integration for individual process solutions can be projected at any time upon request.



Innovative spraying system for wet cutting.

Spraying the saw tooth with a special, highly wood-compatible spraying agent creates a vapor that lubricates and cools the saw blades. The spraying intervals can be customized according to necessity.

The benefits: improved lifetime of the thin-kerf saw blade thanks to reduced friction and the prevention of resin build-up.

The benefits of the spraying system are particularly evident when cutting wet wood. But it also demonstrates its performance in applications involving wood species with a high resin or silicate content.

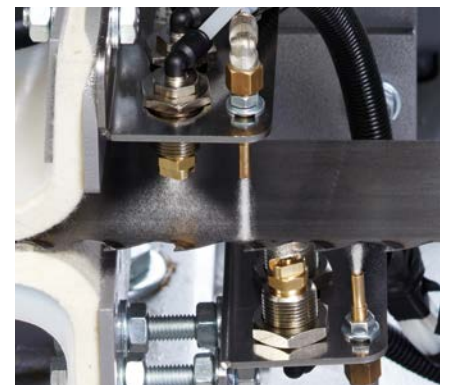

Spraying system for wet cutting

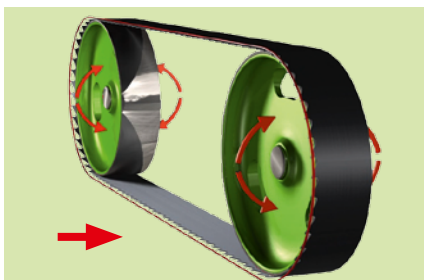

Automatic saw blade regulation.

When cutting non-homogeneous materials such as wood, the saw blade is exposed to different cutting forces. The automatic saw blade regulation uses a sensor to detect the displacement of the saw blade caused by differences in

cutting force. An adjusting mechanism driven by an electromotor controls the pulleys accordingly and guarantees the optimum positioning of the saw blade. This prevents also the saw blade running off the pulley.

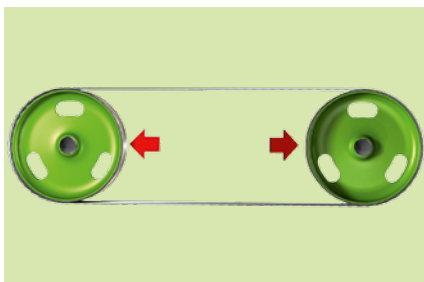

Servo-pneumatic saw blade tensioning.

A servo valve controls the saw blade tension, which is adjusted to match the saw blade dimensions. During non-operating hours, the tension is reduced to prevent wear on the saw blade.

Hinged roller conveyors and powered roller conveyors.

The stable support for long blocks at the machine's in- and out-feed ensures precise cutting. For this purpose WINTERSTEIGER has developed massive roller conveyors and powered roller conveyors in lengths of 2.5 m, 4 m and 5.5 m.



The hinged conveyor systems also offer easy access to the machine door for rapid tool change.



Convenient reversing system.

The reversing system is a user-friendly solution to use a stand-alone DSB Singlehead with one operator only. Working with the reversing system, the operator positions the workpiece manually on the roller conveyor.

After the cut, the block is returned to its starting position, and the saw blade is automatically positioned for the next cut. This process is repeated – without the need to reset the machine – until the whole block has been cut.

One major benefit of this option is that the complete cutting process is fully automated. Apart from removing the cut lamella, there is no need for manual intervention. And there is no need to re-position the saw blade manually.

DSB Singlehead

Figures. Data. Facts.

Technical data

	Standard	Option
Main drive	18,5 kW (25 HP)	32 kW (44 HP)
Max. cutting width	310 mm (12.2") / 660 mm (26"), 32 kW (44 HP)	
Saw blade tensioning system	Pneumatic via manual pressure controller	Servopneumatic
Saw blade motion control (saw blade motion visible via sight window)	Manual via handwheel	Automatic saw blade regulation
Feed speed, infinitely adjustable (depending on wood type and block dimensions)	Standard feed: 4 to 20 m/min (13 – 66 ft/min)	Precision feed: 1 to 15 m/min (3 – 50 ft/min) High-speed feed: 8 to 45 m/min (16 – 150 ft/min)
Saw blade speed, infinitely adjustable	Up to 50 m/sec (164 ft/sec)	Up to 60 m/sec (200 ft/sec) (with 32 kW / 44 HP main drive)
Wet cutting – spraying system		For wet cutting as well as for wood types with a high content of resin or silica's
Voltages*	3 x 400 VAC / 50 Hz 3 x 480 VAC / 60 Hz External switch cabinet at front of main drive for following voltages: 3 x 208 VAC / 60 Hz 3 x 575 VAC / 60 Hz Dimensions of external switch cabinet: W x H x D 600 (24") x 600 (24") x 350 (14") mm	
Diameter – saw pulleys	Ø 915 mm (36")	
Arrangement of sawing module	Horizontal	
Working height	875 mm (35") (+ 10 mm / 0,5" for level control)	
Cutting height adjustment of saw blade	1.7 to 100 mm (0,066" – 4")	
Durable saw blade guide	Carbon guide	
Saw blade lubrication	Via compressed air lubricator	
Compressed air connection	Operating pressure 6 bar (90 psi)	
Required extraction force	Min. 200 liters/min (7 cubic feed/hour)	
Suction fitting (optionally at top or side)	1 x Ø 150 mm	
Extraction capacity	Min. 2000 m³/h (70,570 cubic feed/hour)	
Required air speed	30 to 32 m/sec (100 – 105 feed/sec)	
Power and compressed air inlet	Optionally at top or side	

* Other voltages available on request

Block/lamella data

	Standard
Block width series 310	Min. 30 mm (1.2") / max. 310 mm (12.2")
Block width series 660	Min. 30 mm (1.2") / max. 660 mm (26")
Adjustable saw blade guiding (depending on block width)	Approx. 150 to 310 mm (5.9" to 12.2") bzw. ca. 500 bis 660 mm (19.7" to 26")
Cutting precision (depending on ongoing material and tool characteristics)	Approx. +/- 0.15 mm / 0.006" (up to a block width of 310 mm / 12.2") Approx. +/- 0.20 mm / 0.008" (up to a block width of 660 mm / 26")
Min. / max. block height	5 mm (0.2") / 165 mm (6.5")
Optional first cut of block	First cut of block optionally straight or inclined by 2°
Cutting of wooden blocks with different moisture levels	For dry or wet cutting
Cutting of wooden blocks with varying preparation	Rough cut, 1 to 4-sided planed material
Cutting of wooden blocks of various qualities	Longitudinal/latitudinal deformation, cupped or twisted
Min. / max. block length	350 mm (13.78") / unlimited
Individually selectable block guide	Lateral or central block guide
Lamella thickness (depending on wood type and block dimensions)	> 1.7 mm / 1/16" (from 1.3 mm / 1/20" available on request)

We reserve the right to make technical alterations

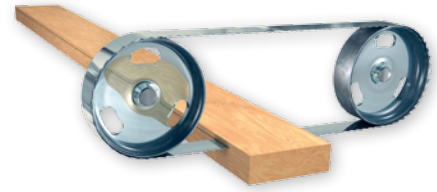

Saw blade data

Thickness of cutting kerf	From 1.0 mm (0.039")
Thickness of base material	From 0.7 mm (0.027")
Width of saw band	80 mm (3.15")
Length saw band for cutting widths up to 310 mm (12.2")	5500 mm (216.5")
Length saw band for cutting widths up to 660 mm (26")	6500 mm (255.9")
Easy, ergonomical saw blade change (sash doors swivel through 145°)	Approx. 2 min. (2 persons)

Specifications

	DSB Singlehead 310	DSB Singlehead 660
Height	2025 mm (80")	2025 mm (80")
Width	3200 mm (126")	3700 mm (146")
Width with custom voltage (External switch cabinet 600 x 600 x 350 mm at front of main drive, observe door opening of 600 mm)	3600 mm (141")	4100 mm (161")
Depth	1000 mm (1300 mm), 39" (51")	1000 mm (1300 mm), 39" (51")
Depth with doors open	3270 mm (129")	3700 mm (146")
Weight	3800 kg (8,400 lbs)	4500 kg (10,000 lbs)
Foundation load	5000 kg (11,000 lbs)	
Transport options for machine	2 brackets for fork-lift on underside of machine, 2 fittable crane eyes on top of machine	
Transport dimensions machine	W x D x H: 3200 (3700) x 1300 x 2025 mm (126" / 146" x 51" x 80")	
Transport dimensions with wooden crate	W x D x H: 4200 x 1500 x 2400 mm (165" x 59" x 95")	
Transport dimensions with pallet	W x D x H: 4200 x 1500 x 2250 mm (165" x 59" x 89")	

We reserve the right to make technical alterations

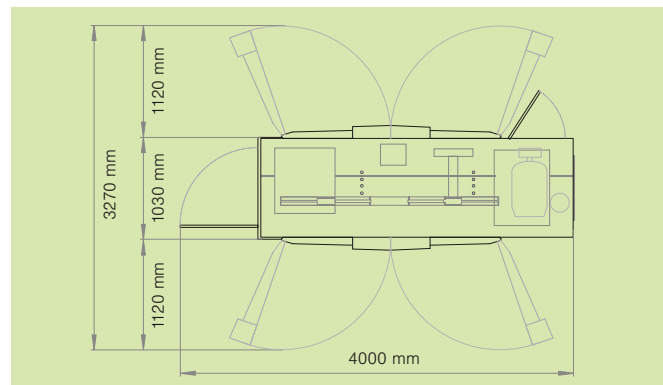
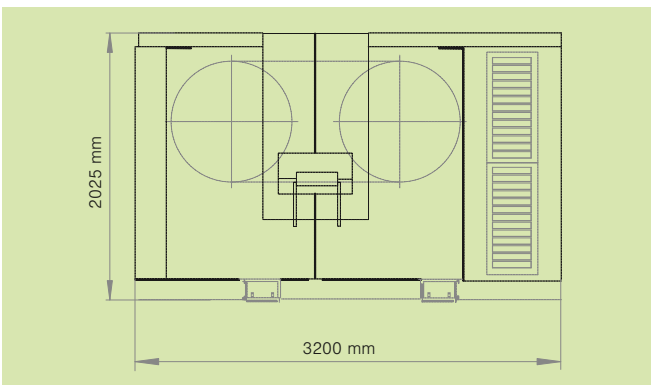

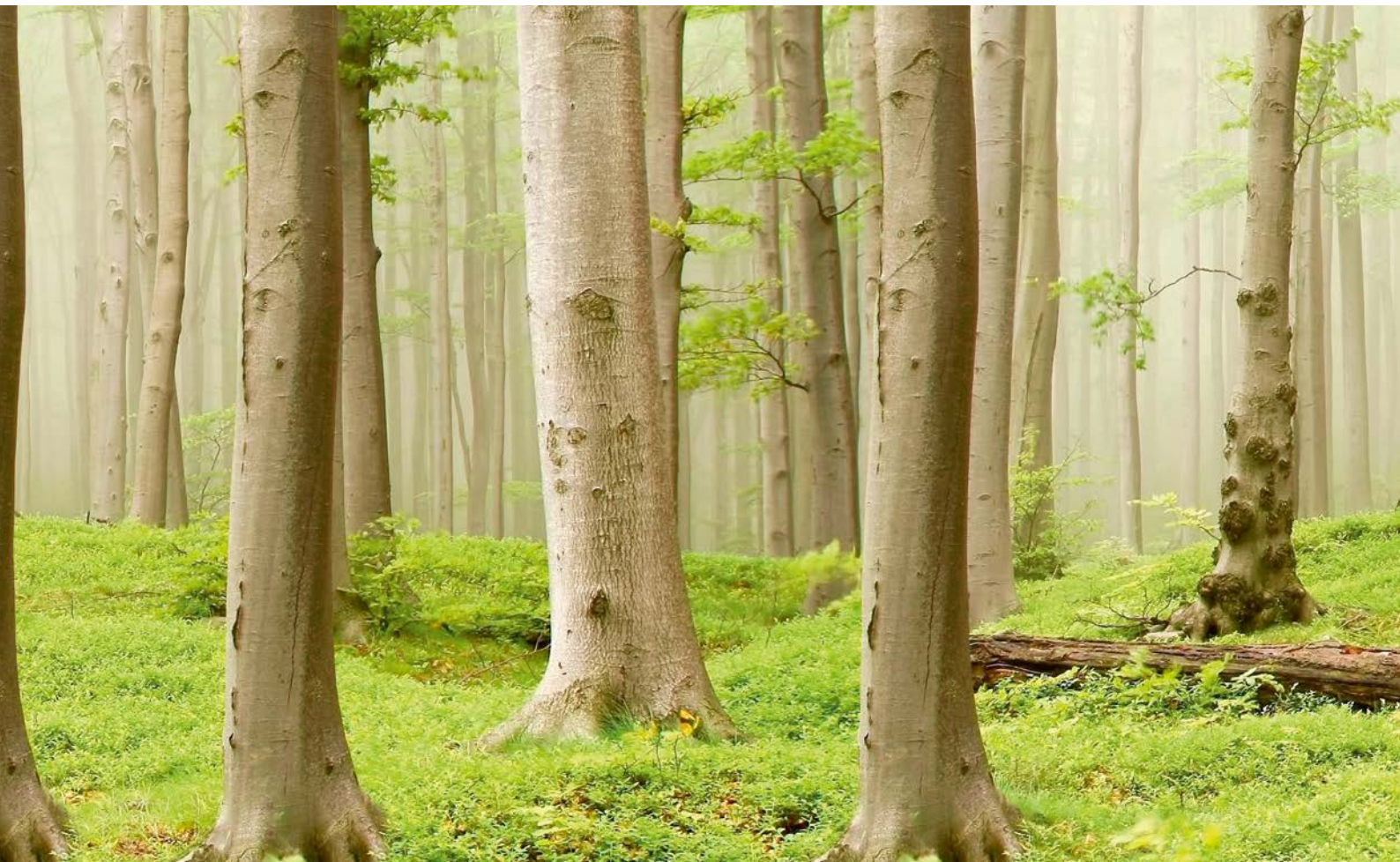

DSB Twinhead NG XM

The next-generation thin-cutting band saw with multiple modules.

Flexibility is adapting to customers' wishes not to common practice.

The quality of investments is measured on the realization of meeting predetermined targets.

Thanks to its cutting kerf, the DSB Twinhead NG XM is the perfect choice when high output and maximum flexibility are the key factors.

Following the development of the technically revolutionary DSB Singlehead and the success of the DSB Twinhead, with its sawing units arranged in parallel, merging the two models was the next logical step. The impressive result is a new generation of machines: the multiple-module thin-cutting band saw DSB Twinhead NG XM.

The strong points – price and performance – are already available in the compact twin-module basic configuration. In addition, the DSB Twinhead NG XM machines can be set up in series to create an entire production system, thus revolutionizing high-quality thin-cutting in terms of performance and accessibility. Specifically for these applications:

- Parquet flooring / Engineered floors
- Multi-layer boards
- Glue-laminated wood
- Doors
- Windows
- Furniture
- Pencil slats
- Ski/snowboard components
- Musical instruments
- Saw mill - secondary cut

If you are looking for customized solutions for non-wood materials, please ask us!



Your benefits summed up:

2 modules evolution for modular revolution

- 2-modular basic configuration
- Parallel arranged saw moduls
- Unique price-/performance ratio

High performance and maximum dimensions

- Expandable to a full production system
- Optimum accessibility with minimum footprint
- Cutting width up to 310 mm, block height up to 165 mm, cutting height up to 160 mm

Outstanding precision thanks to leading technology

- Innovative cutting-edge sawing systems for highest precision
- Unique feed system for any material characteristics
- Machine and tool from our own development and production

How to exceed high expectations? By being able to offer benefits as standard.

Future-oriented success strategies originate in the minds of people whose passion is to achieve something which is above average. Only in this way is it possible to create developments which anticipate not just tomorrow but the day after tomorrow. The DSB Twinhead NG XM does this in the field of thin-cutting technology.

Twin-module evolution meets modular revolution.

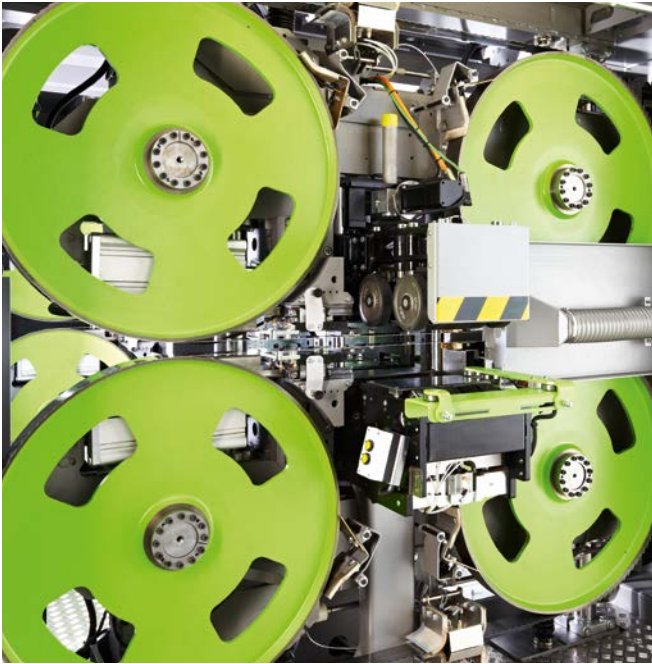

DSB Twinhead NG XM

Save space thanks to horizontal saw units.

Already the twin-module basis version of the new DSB Twinhead NG XM offers two saw units, making it the double-cutting system with smallest footprint.

The parallel design of the saw modules (= Twinhead concept) is the ideal solution wherever multiple cutting is required.

The servo-driven module adjustment via precision threaded spindles allows up to 10x faster height adjustment. This allows for fast and optimized use of the 160 mm cutting height of the DSB Twinhead NG XM.

Cutting width up to 310 mm, block height up to 165 mm.

For the DSB Twinhead NG XM, the proven block transport system of the DSB Singelhead was duplicated.

The maximum block height is 165 mm at a cutting height of up to 160 mm. Depending on the configuration, the feed speed of the DSB Twinhead NG XM is infinitely variable up to 45 m/min.

Unrivaled price/performance ratio.

Already the basic configuration of the DSB Twinhead NG XM – with its ergonomic advantages, minimum footprint and maximum performance – is a highlight. The Twinhead concept with two modules in one machine keeps the costs of investment within comfortable limits.

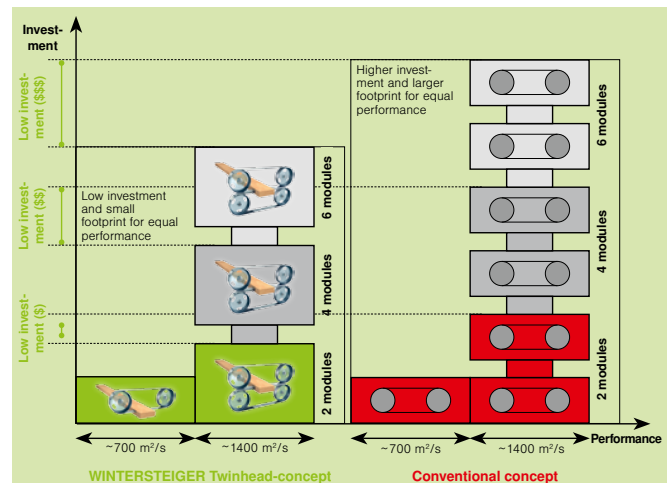

The Twinhead concept – an unrivaled price/performance ratio

High performance and maximum dimensions.



DSB Twinhead NG XM, modularly extended

Expandable to a full production system.

Machines connected in series are designed as a complete production system.

It is also possible to extend existing machines by adding on additional machines in line at any time upon request.

The automation and integration of individual process solutions are another part of WINTERSTEIGER's core competence.

Accessible production systems.

The innovative design of both machine and serial installations, ensures that all machine components are optimally accessible while requiring minimum space.

These ergonomics minimize both time and cost required for the tooling, setting up and changing of saw blades. This concept also offers full access to the machine area.

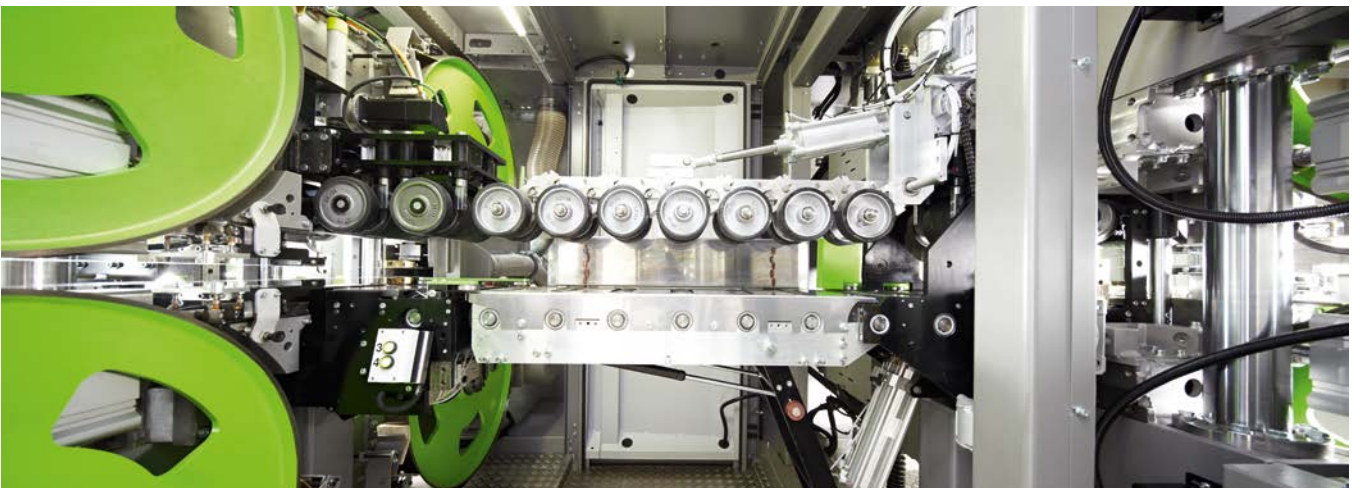

Outstanding precision thanks to leading technology.

Innovative cutting-edge sawing systems for highest precision.

Instead of simply overstretching the band-saw blade, WINTERSTEIGER uses an automatic band tracking control to keep the band-saw blade in position on the saw pulleys. Apart from preventing wear and retaining the inner saw blade tension, this also preserves the working surface of the saw pulleys.

Combined with the carbon guides, this optimal saw blade tension allows an aggressive positioning of the saw blade guides. As a result, the saw blade tension is concentrated in the cutting area.

This unique technology package, in combination with the rigid block feeding system ensures maximum cutting precision when using minimum cutting kerfs starting at 1.0 mm.

Innovative cutting-edge sawing systems

- Unique feed system
- Automatic saw blade regulation
- Servo-pneumatic saw blade tensioning
- High-tech carbon-guide

Unique feed system for all block characteristics.

Driven feed rollers top and bottom guarantee a continuous block feeding despite extreme workpiece characteristics. The transport rollers, rubber-shoed and special treated, and the highly innovative counter-pressure loaded system guarantee optimum grip as well as minimum friction for wet or dry material.

At the same time, the hard chrome-plated supporting table ensures that the workpiece is as stable as possible (optimally aligned).

The feed rollers are electronically controlled and infinitely adjustable at the in-feed and out-feed (4 – 20 m/min).

The vertical stabilization of the workpiece in the cutting area is the basis for the maximum precise cut.

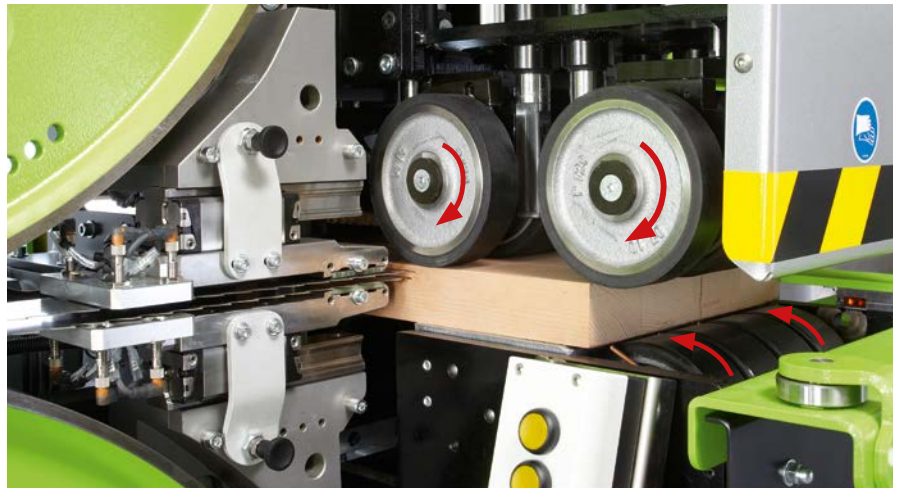

Driven feed rollers top and bottom

The DSB Twinhead NG XM owes its unusually high level of precision to the hard chrome-plated supporting table. Additional driven pressure rollers immediately above the cutting area guarantee the constant stability of the workpiece across its full width. This gives you the ability to cut not only pre-planed material, but also uneven and rough-sawn-blocks with longitudinal or latitudinal deformations, twisted, bend or cupped.



Blocks with longitudinal/latitudinal deformation, cupped or warped



Block dry cutting



Block wet cutting

Automatic saw blade regulation.

When cutting non-homogeneous materials such as wood, the saw blade is exposed to different cutting forces. The automatic saw blade regulation uses a sensor to detect the displacement of the saw blade caused by differences in cutting force.

An adjusting mechanism driven by an electromotor controls the pulleys accordingly and guarantees the optimum positioning of the saw blade. This prevents also the saw blade running off the pulley.

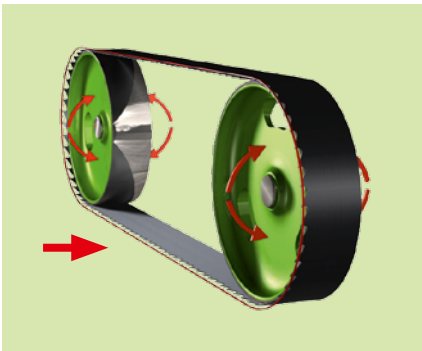

Servo-pneumatic saw blade tensioning.

A servo valve controls the saw blade tension, which is adjusted to match the saw blade dimensions.

During non-operating hours, the tension is reduced to prevent wear on the saw blade.

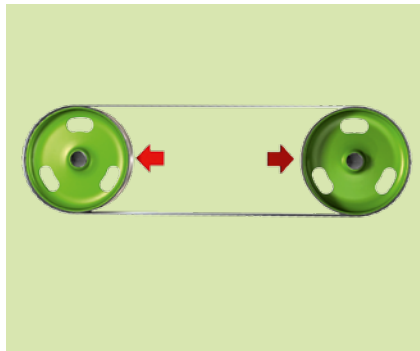

Versatile wood program.

Using the special wood program of the DSB Twinhead NG XM, you can store the cutting, lamella and saw blade parameters for each wood type and retrieve them as needed.

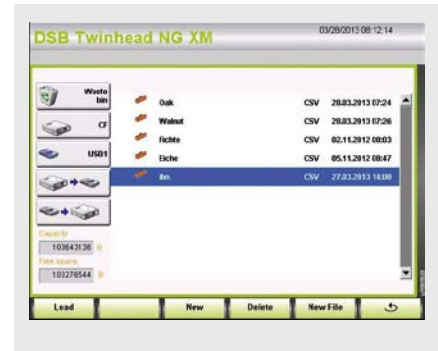

The saw blade guiding system is individually adjustable to match the workpiece width. The benefit: optimum saw blade tension in the cutting area resulting in maximum cutting precision.

High-tech carbon-guide.

This high-tech composite material made of abrasion-proof carbon fibers and heat-resistant epoxy resin guarantees precise blade guiding and an extremely long lifetime.



Extremely abrasion-resistant high-tech carbon guide

Great operating comfort.

The DSB Twinhead NG XM is impressively easy to use. The touch screen display and the easy-to-understand menu guide the user through the program. Practical: The software includes a memory function for regularly recurring cutting parameters.

It also features a multilingual user interface as well as numerous service and help menus. Programs are available for cutting, wood type and saw blade, for example, along with production data logging, diagnostics and maintenance displays.



We make you a clear offer. And still leave you the freedom to choose.

The quality of an offer lies not only in its clearly redeemable value promise. Its quality also increases with the opportunity to choose, for example, between options which further improve the result depending on individual needs.

Powerful 32 kW main drive.

When dimensional and capacity requirements grow, more power is the only answer. In this case, WINTERSTEIGER recommends the powerful 32 kW quality motor as the main drive.

The perfect feed for all applications.

For high-performance requirements at maximum capacity ranges, the DSB Twinhead NG XM allows high-speed feeding from 8 to 45 m/min. For even higher precision, special applications, sensitive materials or XXL dimensions, feeding can be reduced to speeds from 1 to 15 m/min.

Innovative spraying system for wet cutting.

Spraying the saw tooth with a special, highly wood-compatible spraying agent creates a vapor that lubricates and cools the saw bands. The spraying intervals can be customized according to necessity.

The benefits: improved lifetime of the thin-kerf saw blade thanks to reduced friction and the prevention of resin build-up.

The benefits of the spraying system are particularly evident when cutting wet wood. But it also demonstrates its performance in applications involving wood species with a high resin or silicate content.

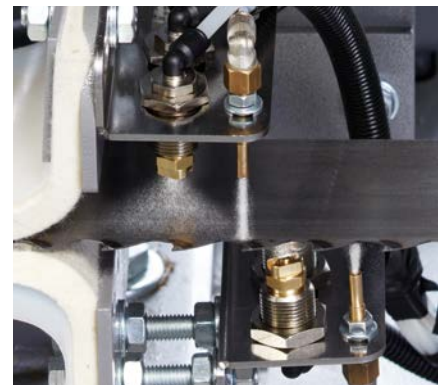

Spraying system for wet cutting



Hinged roller conveyors and powered roller conveyors.

The stable support for long blocks at the machine's in- and out-feed ensures precise cutting. For this purpose WINTERSTEIGER has developed massive roller conveyors and powered roller conveyors in lengths of 2.5 m, 4 m and 5.5 m.

The hinged conveyor systems also offer easy access to the machine door for rapid tool change.

DSB Twinhead NG XM

Figures. Data. Facts.

Technical data

	Standard	Option
Main drive rating	18.5 kW (25 HP)	32 kW (44 HP)
Max. cutting width	310 mm (12.2")	
Feed speed, infinitely adjustable (depending on wood type and block dimensions)	Standard feed: 4 – 20 m/min (13 – 66 ft/min)	Precision feed: 1 – 15 m/min (3 – 49 ft/min) High-speed feed: 8 – 45 m/min (26 – 148 ft/min)
Saw blade speed, infinitely adjustable	10 – 50 m/sec (33 – 164 ft/sec)	10 – 60 m/sec (33 – 197 ft/sec) (with 32 kW / 44 HP main drive)
Wet cutting – spraying system		For wet cutting as well as for wood types with a high content of resin or silica's
Saw blade tensioning system	Servo-pneumatic	
Saw blade motion control (saw blade motion visible via sight window)	Automatic saw blade regulation	
Voltages*	3 x 400 VAC / 50 Hz 3 x 480 VAC / 60 Hz External switch cabinet at front of main drive for following voltages: 3 x 208 VAC / 60 Hz 3 x 575 VAC / 60 Hz	
Diameter – saw pulleys	Ø 915 mm (36")	
Arrangement of sawing module	Horizontal	
Operating height	Approx. 1,300 mm (51") (approx. 1,100 mm / 43") with sunken fundament)	
Cutting height adjustment of saw blade	Approx. 1.7 to 160 mm (0.067" – 6.29")	
Durable saw blade guide	Carbon guide	
Saw blade lubrication	Via compressed air lubricator	
Compressed air connection	Operating pressure 6 bar (90 psi)	
Required extraction force	Min. 500 liters/min (17.7 cubic feed/min) per machine	
Suction fittings top	1 x Ø 200 mm + 1 x Ø 100 mm per machine	
Extraction capacity	Min. 4,500 m³/h (158,900 cubic feed/hour) per machine	
Required air speed	30 to 32 m/sec (100 - 105 feed/sec) per machine	
Power and compressed air inlet	Optionally at top or side	

* Other voltages available on request

Block/lamella data

	Standard
Block width	Min. 30 mm / max. 310 mm (1.2" / 12.2")
Saw blade guiding	Adjustable on one side
Cutting precision (depending on original material and tool characteristics)	Approx. +/- 0.15 mm (0.006")
Block height min. / max.	5 mm / 165 mm (0.19" / 2.95")
Block length min. / max.	350 mm (13.78") / unlimited
Lamella thickness (depending on wood type and block dimensions)	> 1.7 mm (0.067")
Individually selectable block guide	Lateral or central block guide

We reserve the right to make technical alterations.

Saw blade data

Thickness of cutting kerf	From 1.0 mm (0.039")
Thickness of base material	From 0.7 mm (0.027")
Width of saw band	80 mm (3.15")
Length saw band	5500 mm (216.5")
Easy & ergonomical saw blade change (sash doors swivel through 125°)	Approx. 2 min (2 persons)

DSB Twinhead NG XM

Figures. Data. Facts.

Dimensions	DSB Twinhead NG 2 XM	DSB Twinhead NG 4 XM	DSB Twinhead NG 6 XM
Height	2695 mm (160.1")		
Width	4030 mm (158.66")		
Depth	1550 mm (61")	3920 mm (154.33")	6235 mm (245.47")
Depth with doors open	3750 mm (147.64")	6050 mm (238.19")	8365 mm (329.33")
Weight	Approx. 8000 kg (17637 lbs)	Approx. 16000 kg (35274 lbs)	Approx. 24000 kg (52911 lbs)
Foundation load	10000 kg (22046 lbs)	20000 kg (44093 lbs)	30000 kg (66139 lbs)
Transport options for machine	2 brackets for fork-lift on underside of machine 2 fittable crane eyes on top of machine		
Transport dimensions machine (W x D x H)	4030 x 1550 x 2695 mm (158.66" x 61" x 106.1")	4030 x 1550 x 2695 mm (158.66" x 61" x 106.1") per machine	
Transport dimensions with pallet (W x D x H)	4200 x 2340 x 2950 mm (165.35" x 92.13" x 116.14")	4200 x 2340 x 2950 mm (165.35" x 92.13" x 116.14") per machine	
Transport dimensions with wooden crate (W x D x H)	4250 x 2400 x 2980 mm (167.32" x 94.49" x 117.32")	4250 x 2400 x 2980 mm (165.35" x 92.13" x 116.14") per machine	
Transport dimensions in seaworthy crate (W x D x H)	4250 x 2400 x 3115 mm (167.32" x 94.49" x 122.64")	4250 x 2400 x 3115 mm (165.35" x 92.13" x 116.14") per machine	

We reserve the right to make technical alterations.

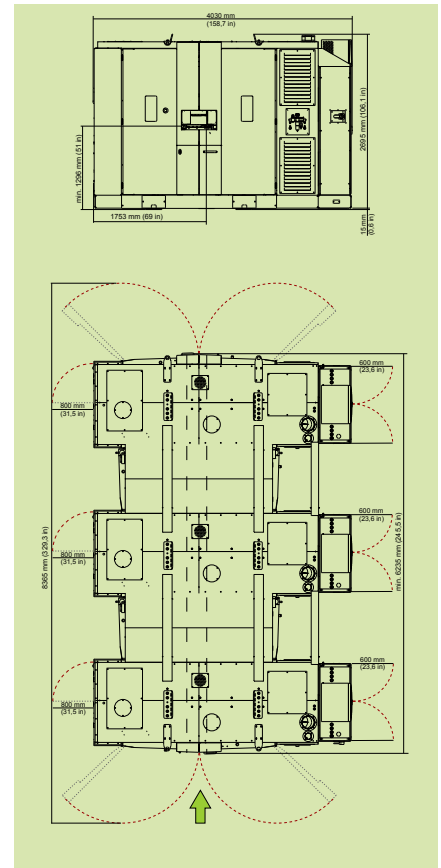
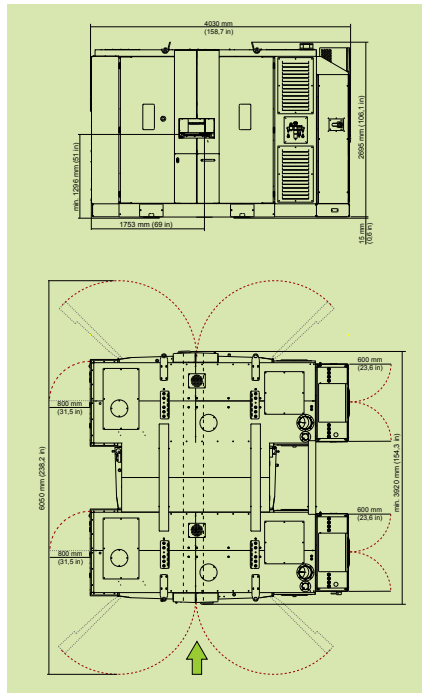
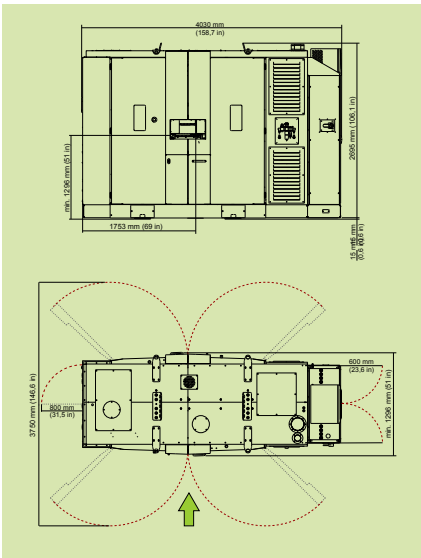



Saw blades from in-house development and production.

Demanding customers require individual tools. WINTERSTEIGER supplies the best material, optimum saw blade dimensions and tooth geometries in line with requirements.

WINTERSTEIGER is able to supply the perfect blade for frame or band saws, meeting all customer needs. The extremely thin kerf, along with the highest possible precision, is the ideal basis for manufacturing high-quality products and is providing additional earning opportunities for each customer. For WINTERSTEIGER, shortest delivery times with greatest possible flexibility go without saying.

Compelling thin-cutting systems and band saws by WINTERSTEIGER!

Optimum solution:

- 30 years of know-how with all types of wood
- References from all over the world
- Broad product range with different base materials, tooth pitches and kerfs
- Customer-oriented saw development
- Optimum wood yield using appropriate tools

Maximum efficiency:

- Immediate further processing of the lamella without subsequent calibration
- Kerf from 0.7 mm
- Clean lamella surface
- Maximum lamella precision
- Efficient use of material thanks to constantly perfect kerf

Reliable partner:

- Top quality servicing of machines, tools and saws
- Customized systems for your success
- Consistently high quality and ability to supply
- High level of customer satisfaction



Quick help – with the WINTERSTEIGER Remote Service.

Quality and speed are the deciding factors in the event of a breakdown. The global WINTERSTEIGER sales and service networks guarantee optimum support in case of technical queries and fastest possible support by professional service engineers.

Additionally to improve availability and reduce response times, you also have the option of equipping your WINTERSTEIGER thin-cutting band saws with remote service. To detect a problem takes only seconds with the WINTERSTEIGER Remote Service. Your machine's online connection is the directly link to our technical customer service. Error detection and diagnosis are done almost in real time, along with data analyses, optimizations and service measures. The WINTERSTEIGER Remote Service works with LAN/WAN/GPRS/UMTS/HSDPA.

Your benefits:

- Increased machine availability for operation
- Shorter downtimes thanks to remote diagnosis
- Reduced maintenance costs
- Routine transmission of current software updates
- Data backup and secure spare part identification
- Support of maintenance staff and service crew
- Machine standstills are avoided

Our services:

- Provision of the hardware (router)
- Registration at the WINTERSTEIGER Remote Service portal
- Free remote service for the first year (service can be extended by maintenance agreement)

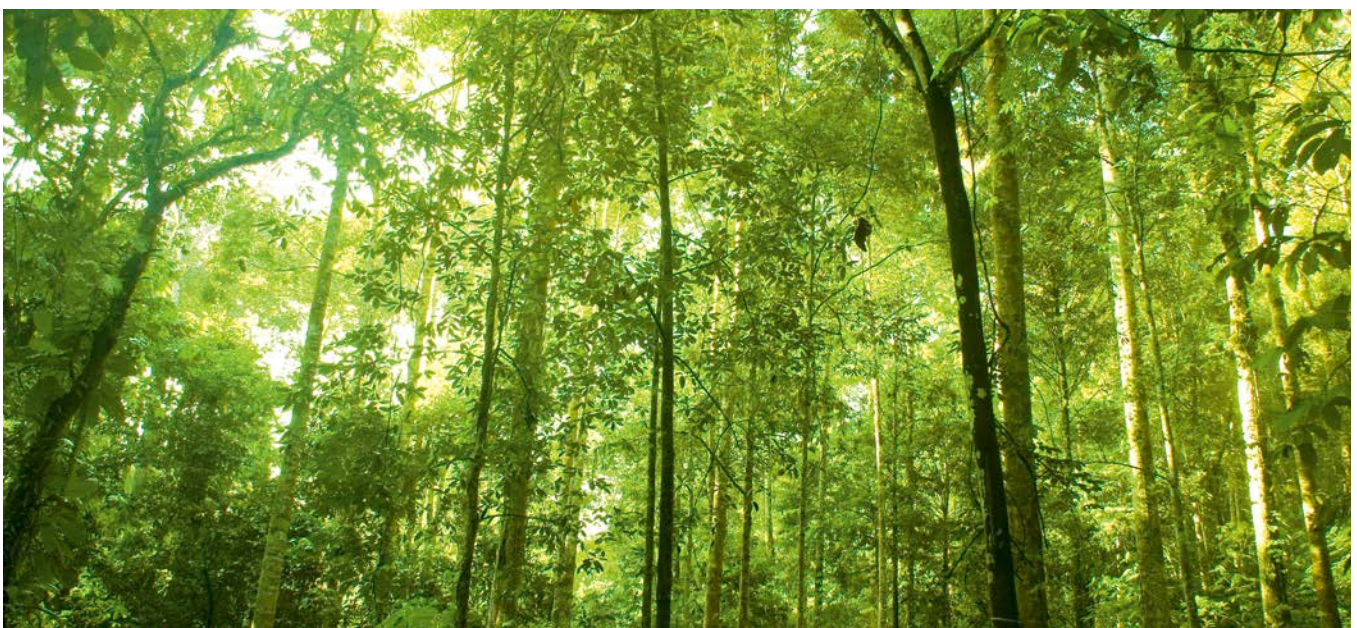

WINTERSTEIGER After Sales Service. Support starts where delivery ends.

The best time for assessing the quality of an investment is in the many years after its delivery. Therefore WINTERSTEIGER has established a global after sales service.

Installation and training

WINTERSTEIGER ensures both with its experts world-wide and of course on site.

Support

We provide continuous support to quickly optimize the profitability of the machine for our customers.

Proactive maintenance

Maintenance and preventive active replacement of pre-defined wear parts at firmly defined times (e.g. during company holidays) which also helps to keep maintenance and repair costs to a minimum.

Contracts for consumables and saw blades

These agreements enable us to plan our annual requirements in advance and save costs which of course we pass on immediately to our customers.

Other benefits:

- Just-in-time delivery of saw blades
- Availability at short notice
- Warehousing of saw blades by WINTERSTEIGER

Helpdesk on call service

This service underlines our high level, global service commitment to our partners and ensures first-class support even outside our normal business hours.



WINTERSTEIGER WOODTECH.

The value of wood increases with the level of its finish.

Wood as a sustainable and growing resource with all its brilliant properties is being rediscovered more intensively than ever before. Thin-cutting in particular is proving to be one of the key technologies in the processing of wood. WINTERSTEIGER already has over 30 years of know-how in this segment and has been a market leader for many years.

Sales of more than 1500 thin-cutting frame saws underline WINTERSTEIGER's global market leadership which is based on a philosophy that is transparent and pursued consistently: To create clear added values for the future by being receptive to innovation whilst offering high-performance and excellent operating reliability.

WINTERSTEIGER's technology offers absolutely perfect conditions for the production of products like

- Engineered floors
- Multi-layer boards
- Doors
- Windows
- Furniture
- Pencil boards
- Musical instruments and many more

Conceived and put into practice by a team of users, technicians and designers, the entire product range of thin-cutting frame saws to the technology for gluing and pressing excels with a wide variety of advantages.

- High precision
- Minimum cutting kerfs
- Ready to glue surfaces
- Further processing of lamellas without additional work stages

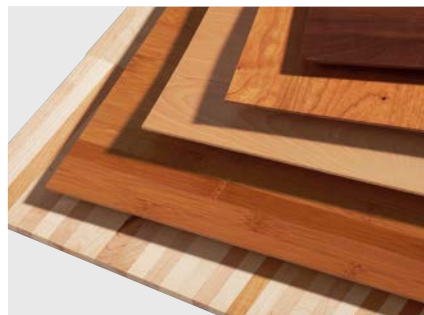
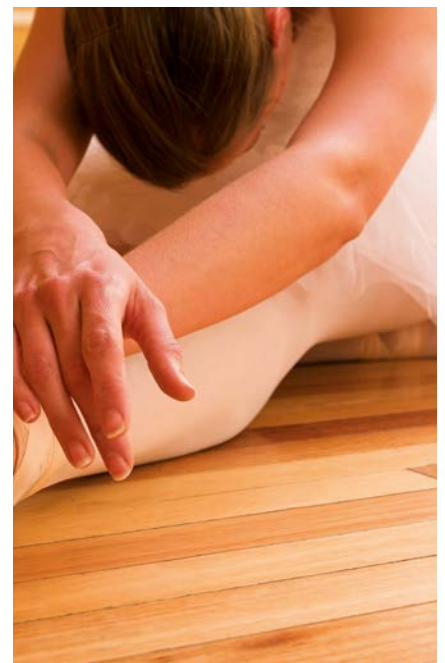

Precise cutting of all non-wood materials.

As the quality leader, WINTERSTEIGER is present wherever precise cutting with minimal material loss is at a premium. This applies to various materials not made of wood. Ask for our customized solutions!



WINTERSTEIGER. A Global Player.

WINTERSTEIGER AG is a special-purpose machine builder based in Upper Austria and has concentrated on niche markets since its foundation in 1953.

The internationalization of the markets and the technological revolutions have become the deciding factors in the global competition. WINTERSTEIGER has always considered such

challenges opportunities and has taken advantage of them. This has resulted in continuous growth, which is further ensured by the innovative power of its employees and driven

through strategic acquisitions. In this way we succeeded in providing the optimal conditions for long-term and stable partnerships with our customers.

■ Business Unit SEEDMECH

- Turnkey solutions for plant breeding and research

■ Business Unit SPORTS

- One-stop supplier for ski and snowboard rental and servicing
- Systems for hygienic drying of sports goods and work clothes
- Fit-optimizing solutions and individual sports shoe adjustments

■ Business Unit WOODTECH

- Process solutions for precision thin-cutting, wood repairs and cosmetics
- Saw blades for wood and food

■ Business Unit METALS

- Levelling technology machines and systems (KOHLENER Maschinenbau GmbH)
- Machines for the automatic deburring of sheet metal (Paul Ernst Maschinenfabrik GmbH)

■ Business Unit AUTOMATION

- Plants and automation solutions for industrial manufacturing companies (VAP Gruber Automations GmbH)

- 21 subsidiaries
- 60 representatives
- Sales to 130 countries
- 90 % export share
- Global market leader in SEEDMECH, SPORTS and WOODTECH



Success begins with the right decisions.
At the right time. We look forward to you!

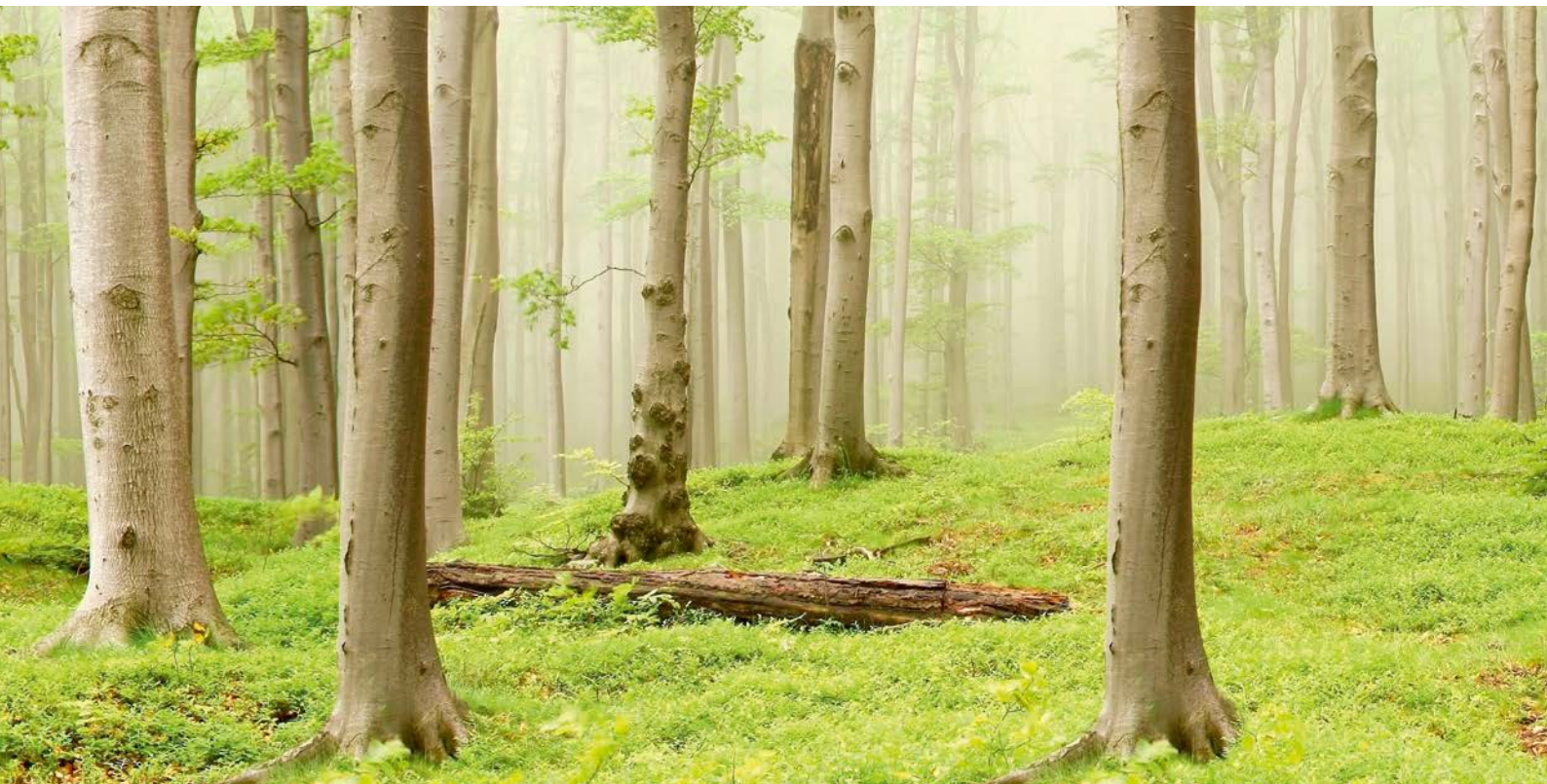

WINTERSTEIGER
Thin-cutting & Repair

Headquarters:

Austria: WINTERSTEIGER AG, 4910 Ried, Austria,
Dimmelstrasse 9, Tel.: +43 7752 919-0, Fax: +43 7752 919-58,
woodtech@wintersteiger.at

International Companies:

China: WINTERSTEIGER China Co. Ltd., Room 902, Building 5
Lippo Plaza, No. 8 Ronghua Middle Road, Economic and Technical
Development Zone, 100176 Beijing, Tel.: +86 10 5327 1280,
Fax: +86 10 5327 1270, office@wintersteiger.com.cn

France: SKID WINTERSTEIGER S.A.S.,
93 Avenue de la Paix, 41700 Contres, Tel.: +33 254 790 633,
Fax: +33 254 790 744, fpasqual.wintersteiger@wanadoo.fr

Russia CIS: OOO WINTERSTEIGER, 117218 Moscow,
Krzhizhanovsky str. 14, build. 3, Tel.: +7 495 645 8491,
Fax: +7 495 645 8492, office@wintersteiger.ru

South America: WINTERSTEIGER South America
Comércio de Máquinas Ltda., Rua Silveira Peixoto,
1040 sala 1303, Batel, CEP: 80240-120, Curitiba, PR - Brasil
Tel./Fax: +55 41 3343 6853, office@wintersteiger.com.br

Southeast Asia, Australia, New Zealand: WINTERSTEIGER SEA
Pte. Ltd., Singapore 569084, 2 Ang Mo Kio Street 64 #05-03A,
Tel.: +65 6363 3384, Fax: +65 6363 3378,
office@wintersteiger.com.sg

USA, Canada: WINTERSTEIGER Inc.,
4705 Amelia Earhart Drive, Salt Lake City, UT 84116-2876,
Tel.: +1 801 355 6550, Fax: +1 801 355 6541,
mailbox@wintersteiger.com

Representations:

Albania, Bosnia Herzegovina, Croatia, Finland, Japan, Korea, Kosovo, Macedonia, Montenegro, Poland, Portugal, Serbia, Slovenia, Spain, Sweden, Taiwan, Turkey.
Contact details for our representatives are available on www.wintersteiger.com/woodtech.